

Foreword

The formulation of this National Standard was initiated by the Agricultural Machinery Testing and Evaluation Center (AMTEC) with support from the Department of Agriculture (DA).

This standard has been technically prepared in accordance with BPS Directives Part 3:2003 – Rules for the Structure and Drafting of International Standards.

The word “shall” is used to indicate mandatory requirements to conform to the standard.

The word “should” is used to indicate that among several possibilities one is recommended as particularly suitable without mentioning or excluding others.

In the preparation of this standard, the following documents/publications were considered:

Regional Network for Agricultural Machinery (RNAM). *Testing, Evaluation and Modification of Weeders*. Technical Series No. 11:1982.

Regional Network for Agricultural Machinery (RNAM) Test Codes and Procedures for Farm Machinery. Technical Series No. 12:1983.

Smith, D.W., Sims B.G, and D.H. O’Neill. *Testing and Evaluation of Agricultural Machinery and Equipment – Principles and practices*. FAO Agricultural Services Bulletin 110. 1994.

Agricultural Machinery – Weeder – Specifications

1 Scope

This standard specifies the requirements for manual, animal-drawn, and tractor-drawn weeders for dry and wet fields.

2 References

The following normative documents contain provisions, which through reference in this text, constitute provisions of this National Standard:

PAES 102:2000, Agricultural Machinery – Operator’s Manual – Content and Presentation

PAES 103:2000, Agricultural Machinery – Method of Sampling

PAES 107:2000, Agricultural Machinery – Hitch for Walking-type Agricultural Tractor
– Specifications

PAES 118:2001, Agricultural Machinery – Four-Wheel Tractor – Specifications

PAES 142:2004, Agricultural Machinery – Weeder – Methods of Test

3 Definitions

For the purpose of this standard, the following definitions shall apply:

3.1

weeding efficiency

weeding index

percentage of weeds removed/destroyed per unit area

3.2

weeder

implement used to remove/destroy the weeds from an agricultural land

3.3

weeds

unwanted plants growing in a field competing with the main crop for nutrients, moisture and sunlight

4 Classification

The classification of weeders shall be as follows:

4.1 By design of soil working part

4.1.1 Blade type

Type of weeder with rectangular, triangular or crescent shapes with cutting edges sharpened and hardened (see Figure 1)

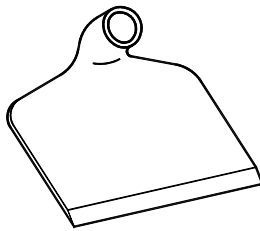

a. Rectangular Shape

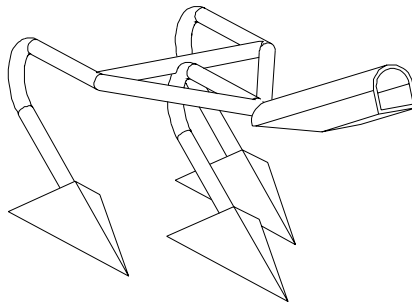

b. Triangular Shape

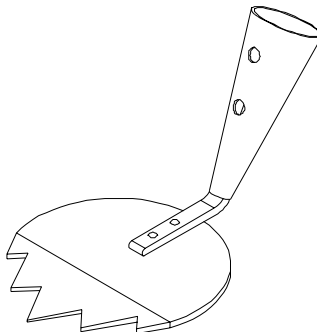

c. Crescent Shape

Figure 1 – Shapes of Blade

4.1.2 Tine type

Type of weeder with a straight, curved, round or square cross-section steel rods with sharply pointed and hardened soil engaging ends (see Figure 2)

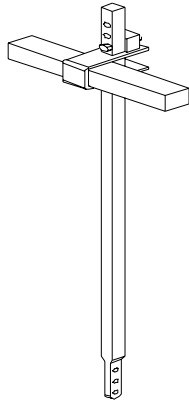

a. Straight, Square Tine

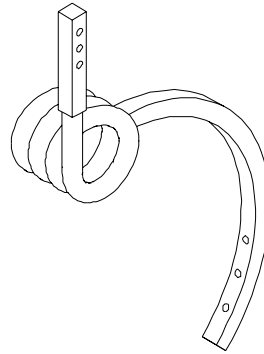

b. Curved, Square Tine

Figure 2 – Shapes of Tine

4.1.3 Rotary type

Type of weeder with curved or straight spikes or puddles radially attached to a common axle, which rotate to uproot and bury weeds (see Figure 3)

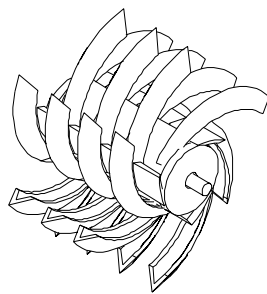

a. Curved Spikes

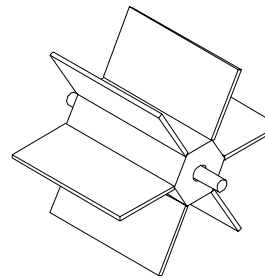

b. Straight Spikes/Puddles

Figure 3 – Different Shapes of Rotary-type Weeder

4.2 By power source

4.2.1 Manually-operated weeders

4.2.1.1 Hand-held weeder (see Figure 4)

Type of weeder which utilize either blade or tine type of soil working parts with short (0.15 m to 0.5 m), medium (>0.5 m to 1 m) and long (>1 m) handles

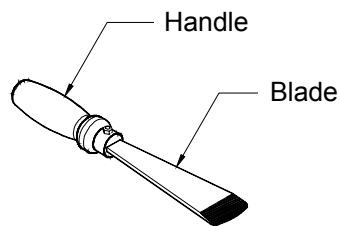

a. Hand-held Weeder with Short Handle

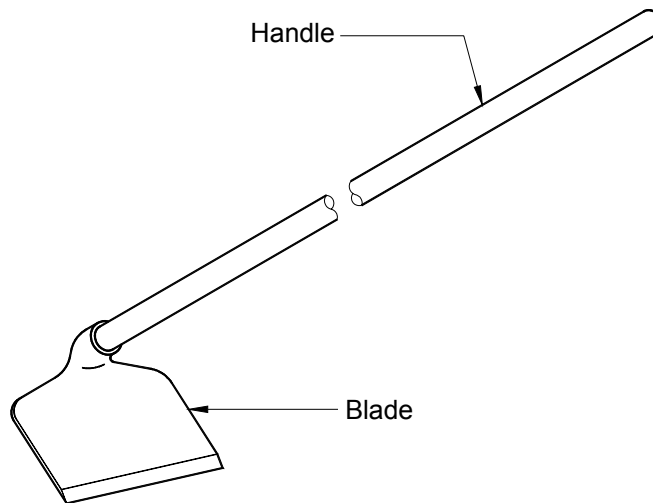

b. Hand-held Weeder with Long Handle

Figure 4 – Hand-Held Weeder

4.2.1.2 Push-type weeder

Type of weeder which utilizes either blade, tine or rotary soil working parts for dry and wet field weeding (see Figure 5)

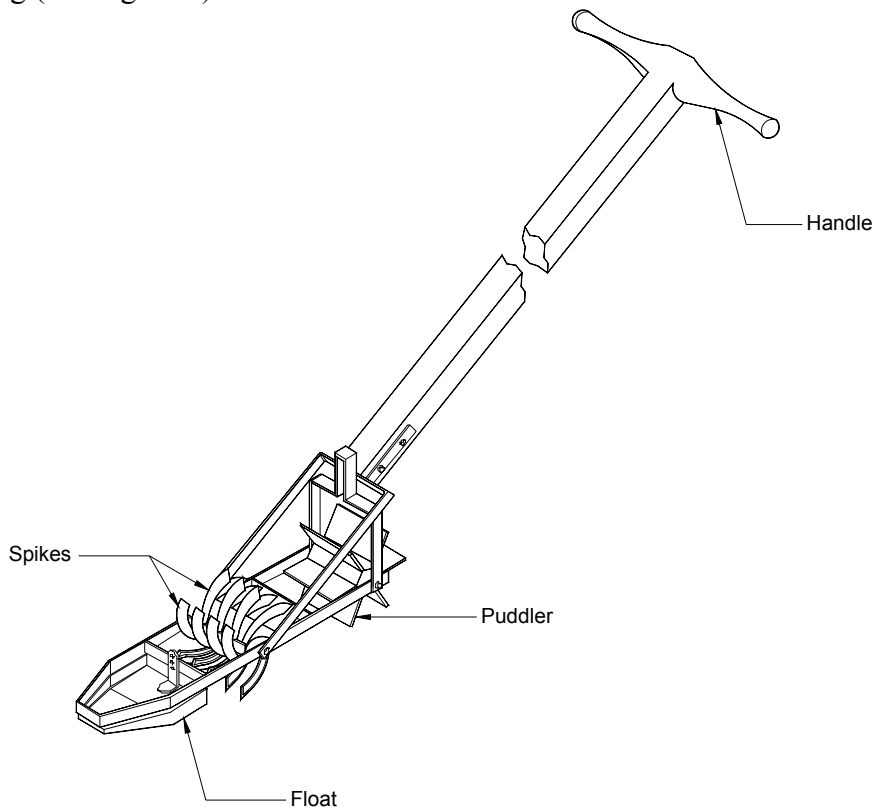

a. For Wet Field Weeding

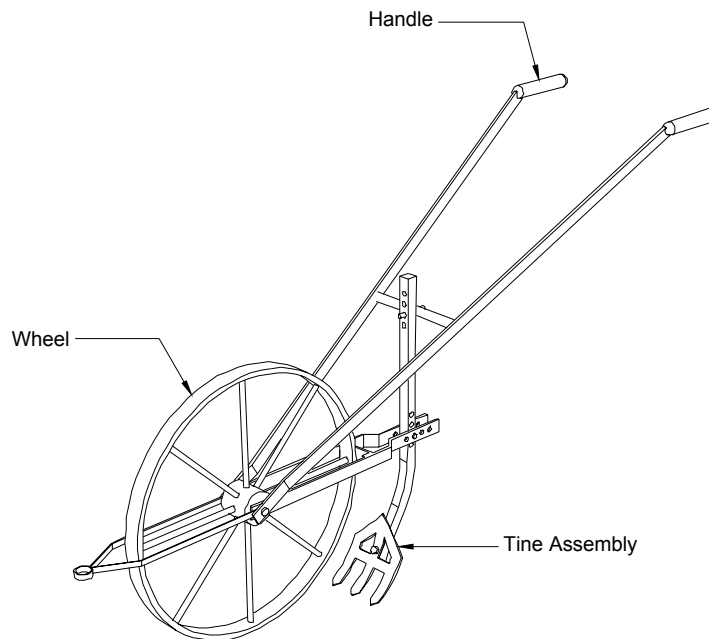

b. For Dry Field Weeding

Figure 5 – Push-Type Weeder

4.2.2 Animal- drawn weeder

Type of weeder in which soil working parts are mounted on a frame or tool bar and pulled by an animal for dry field weeding (see Figure 6)

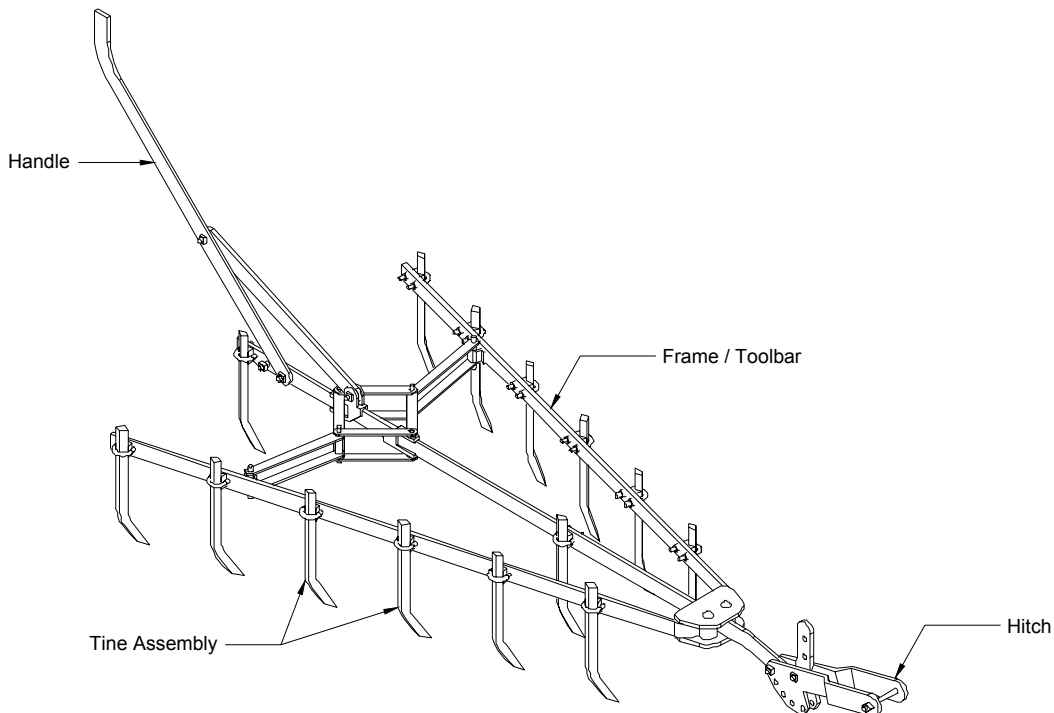

Figure 6 – Animal-Drawn Weeder

4.2.3 Power-weeder

Type of rotary weeder driven by its own engine for wet field weeding (see Figure 7)

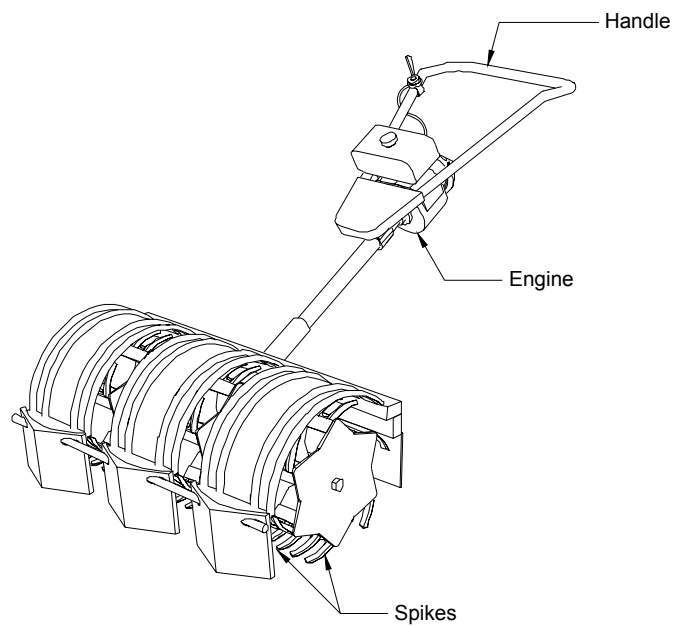

Figure 7 – Power-Weeder

4.2.4 Tractor-mounted weeder

Type of weeder in which soil working parts are mounted on a frame or tool bar and pulled by either two- or four-wheel tractor for dry field weeding (see Figure 8)

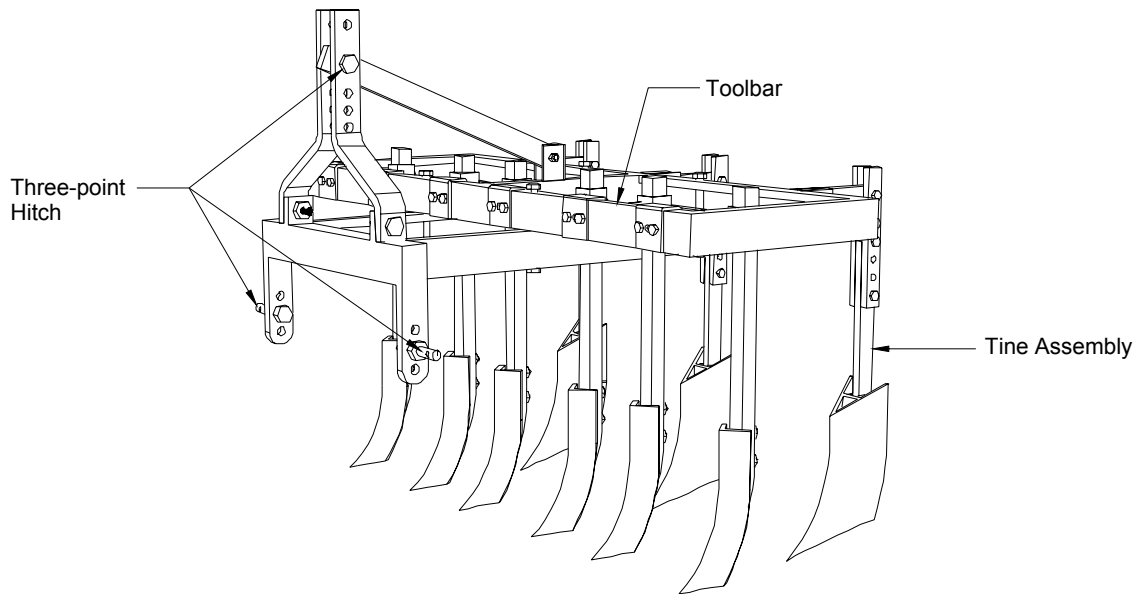

Figure 8 – Four-Wheel Tractor- Mounted Weeder

5 Materials of Construction

5.1.1 Manually-operated Weeders

5.1.1.1 Hand-held

5.1.1.1.1 Carbon steel with at least 50% carbon content and 0.05% sulphur and phosphorus content (e.g. AISI 1055) shall be used in the manufacture of soil-working part. All soil-working parts shall be hardened between 350 and 450 HB (Brinell Hardness), or 37.7 to 47.8 HRC (Rockwell Hardness), or 370 to 483 HV (Vickers Hardness).

5.1.1.1.2 Hard wood, hard plastic and/or steel tube shall be used in the manufacture of handle.

5.1.1.2 Push-type and power weeder

5.1.1.2.1 Carbon steel with at least 50% carbon content and 0.05% sulphur and phosphorus content (e.g. AISI 1055) shall be used in the manufacture of soil-working part. All soil-working parts shall be hardened between 350 and 450 HB (Brinell Hardness), or 37.7 to 47.8 HRC (Rockwell Hardness), or 370 to 483 HV (Vickers Hardness).

5.1.1.2.2 Cast iron shall be used for wheel hub and bushing.

5.1.1.2.3 Mild steel shall be used in the manufacture of frame, axle, floats and handle.

5.1.2 Animal-drawn Weeders

5.1.2.1 Carbon steel with at least 50% carbon content and 0.05% sulphur and phosphorus content (e.g. AISI 1055) shall be used in the manufacture of soil-working part. All soil-working parts shall be hardened between 350 and 450 HB (Brinell Hardness), or 37.7 to 47.8 HRC (Rockwell Hardness), or 370 to 483 HV (Vickers Hardness).

5.1.2.2 Mild steel or hard wood shall be used in the manufacture of frame.

5.1.3 Tractor-drawn Weeders

5.1.3.1 Two-wheel tractor-drawn

5.1.3.1.1 Carbon steel with at least 80% carbon content (e.g. AISI 1080) shall be used in the manufacture of the soil-working part.

5.1.3.1.2 Mild steel shall be used in the manufacture of the toolbar.

5.1.3.1.3 Steel spring shall be used for spring loaded tines.

5.1.3.2 Four-wheel tractor-drawn

5.1.3.2.1 Carbon steel with at least 80% carbon content (e.g. AISI 1080) or alloy steel with at least 0.0005% boron content shall be used in the manufacture of the soil-working part.

5.1.3.2.2 Mild steel shall be used in the manufacture of toolbar.

5.1.3.2.3 Steel spring shall be used for spring loaded tines.

6 Performance Requirements

When tested under PAES 142, the following shall be attained:

6.1 The weeding efficiency shall be at least 80%.

6.2 The percentage of plant damage shall not exceed 6 %.

7 Other Requirements

7.1 The weeder shall be easy to hitch to and unhitch from the animal harness or tractor linkage.

7.2 The hitch of the weeder shall be compatible with the two- and four-wheel tractor linkages as specified in PAES 107 and PAES 118, respectively.

8 Workmanship and Finish

8.1 The weeder shall be free from manufacturing defects such as sharp edges and surfaces that may be detrimental to the operator.

8.2 The weeder shall be free from rust and shall be painted properly.

9 Warranty for Construction and Durability

9.1 Warranty against defective materials and workmanship shall be provided for parts and services except for normal wear and tear of consumable maintenance parts within six months from the purchase of the weeder.

9.2 The construction shall be rigid and durable without breakdown of its major components within six months from purchase by the first buyer.

10 Maintenance and Operation

10.1 A set of manufacturer's standard tools required for maintenance shall be provided.

10.2 An operator's manual which conforms to PAES 102 shall be provided.

11 Sampling

The weeder shall be sampled for testing in accordance with PAES 103.

12 Testing

The sampled weeder shall be tested in accordance with PAES 142.

13 Marking and Labeling

13.1 Each weeder shall be marked in English with the following information using a plate, stencil or by directly punching it at the most conspicuous place:

13.1.1 Registered trademark of the manufacturer

13.1.2 Brand

13.1.3 Model

13.1.4 Serial number

13.1.5 Production date (optional)

13.1.6 Name and address of manufacturer

13.1.7 Name and address of the importer, if imported

13.1.8 Country of manufacture (if imported) / “Made in the Philippines” (if manufactured in the Philippines)

13.2 Safety/precautionary markings shall be provided when appropriate. Markings shall be stated in English and Filipino and shall be printed in red color with a white background.

13.3 The markings shall have a durable bond with the base surface material.

13.4 The markings shall be weather resistant and under normal cleaning procedures, it shall not fade, discolor, crack or blister and shall remain legible.