

Foreword

The formulation of this national standard was initiated by the Agricultural Machinery Testing and Evaluation Center (AMTEC) with funding from the Department of Agriculture.

This standard has been technically prepared in accordance with BPS Directives Part 3:2003 – Rules for the Structure and Drafting of International Standards.

The word “shall” is used to indicate mandatory requirements to conform to the standard.

The word “should” is used to indicate that among several possibilities one is recommended as particularly suitable without mentioning or excluding others.

In the preparation of this standard, the following documents/publications were considered:

Guidelines on Testing and Evaluation of Rubber Roll Huller, National Grains Authority.

Performance Test of Paddy Husker and Rice Whitener. Tsukuba International Center, Japan International Cooperation Agency.

Takao, Hironoshin. Paddy Husker, Group Training Course in Postharvest Rice Processing. Institute of Agricultural Machinery, 1985.

Technical Handbook for the Paddy Rice Postharvest Industry in Developing Countries, James E. Wimberly. International Rice Research Institute, Los Baños, Laguna, 1983

Technical Reference Guide on Grains Postharvest Operations. National Postharvest Institute for Research and Extension, Muñoz, Nueva Ecija, 1994.

CONTENTS		Page
1	Scope	32
2	References	32
3	Definitions	32
4	General Conditions for Test and Inspection	34
4.1	Selection of rubber roll to be tested	34
4.2	Role of manufacturer/dealer/applicant	34
4.3	Test instruments	34
4.4	Test materials	34
4.5	Running-in and preliminary adjustments	35
4.6	Termination of test	35
5	Test and Inspection	35
5.1	Verification of the manufacturer's technical data and information	35
5.2	Quality test	35
5.3	Performance Test	36
6	Laboratory Analysis	37
7	Test Reports	38

ANNEXES

A	Minimum List of Field and Laboratory Test Equipment and Materials	39
B	Specifications of the Rubber Roll	40
C	Quality Test Data Sheet	43
D	Performance Test Data Sheet	44
E	Standard Laboratory Methods in Assessing Hulling Quality of Paddy	46
F	Laboratory Test Data Sheet	47
G	Formulas Used During Calculation and Testing	48

Agricultural Machinery – Rubber Roll for Rice Mill – Methods of Test

1 Scope

This standard specifies the methods of test and inspection for rubber roll for rice mill. Specifically, it shall be used to:

- 1.1 verify the main dimensions, weight, and other technical data of the rubber roll submitted by the manufacturer/dealer;
- 1.2 determine the performance of the rubber roll; and
- 1.3 prepare a report on the results of the tests.

2 References

The following normative documents contain provisions, which, through reference in this text, constitute provisions of these standards:

- | | |
|----------------------|---|
| PAES 102:2000 | Agricultural Machinery – Operator’s Manual – Content and Presentation |
| PAES 103:2000 | Agricultural Machinery – Method of Sampling |
| PAES 216:2004 | Agricultural Machinery – Rubber Rolls for Rice Mills - Specifications |

3 Definition

For the purpose of this standard, the definition given in PAES 216 and the following shall apply:

3.1**broken brown rice**

grain that breaks in the process of dehulling which has a size of less than eighth-tenth (8/10) of the average length of the whole grain

3.2**brown rice**

dehulled paddy with bran layer still intact

3.3**cracked grain**

grain which show signs of fissures or fractures or splinters

3.4**coefficient of hulling**

measure the ability of the huller to remove the hulls

3.5**coefficient of wholeness**

measure the ability of the huller to remove the hull without breaking the grain

3.6**damaged grain**

grain which is heat damaged, weather damaged, sprouted or distinctively damaged by insects, water, fungi, and/or any means

3.7**foreign matter**

all matters other than paddy such as sand, gravel, dirt, pebbles, stones, metal fillings, lumps of earth, clay, mud, chaff, straw, weed seeds and other crop seeds

3.8**hull**

husk

outermost rough covering of the palay grain (palea and lemma) consisting of the empty glumes, floral glumes, and awn

3.9**hulling capacity**

quantity of paddy that the huller can dehulled per total hulling time, expressed in kilogram per hour

3.10**hulling efficiency**

product of the coefficient of hulling and coefficient of wholeness, expressed in percentage

3.11**immature grain**

paddy which are light green and chalky with soft texture

3.12**moisture content**

amount of moisture in the grain expressed as percentage of the total mass of the sample (wet basis)

$$\text{Moisture content (\%, wet basis)} = \frac{M_o - M_i}{M_o} \times 100$$

NOTE

where:

M_o = initial mass in grams of the test portion

M_i = mass in grams of the dry test portion

3.13

paddy

palay

rough rice

unhulled grain of *Oryza sativa* L., that is grain with hull enclosing the grain

3.14

purity

amount of rice grains free of foreign matter expressed as percentage of the total weight of the sample

3.15

running-in period

pre-test operation of the rice huller to make various adjustments prior to the conduct of test until the operation is stable

3.16

whole brown rice

grain or a fraction of grain with its length equal to or greater than eighth-tenth (8/10) of the average length of the whole grain

4 General conditions for test and inspection

4.1 Selection of rubber roll to be tested

Rubber roll on test shall be sampled in accordance with PAES 103.

4.2 Role of manufacturer/dealer/applicant

The manufacturer/dealer/applicant shall submit to the official testing agency specifications and other relevant information on the rubber roll. He/She shall abide with the terms and conditions set forth by an official testing agency. The sampled rubber roll shall be submitted for testing. Experienced operator shall operate, adjust, repair, and shall decide on matters related to the operation of the rubber roll. An officially designated representative of the manufacturer may observe the testing process.

4.3 Test instruments

The instruments to be used shall have been calibrated and checked by the testing agency prior to the measurements. The suggested list of minimum field and laboratory test equipment and materials needed to carry out the rubber roll test is shown in Annex A.

4.4 Test materials

4.4.1 Characteristics

4.4.1.1 Variety : locally grown (as much as possible single variety)

4.4.1.2 Moisture Content : dried to a uniform moisture content of 14 % \pm 1 %

4.4.1.3 Purity : 98 %, minimum

4.4.1.4 Type : Long and slender grains

Note Long grains – paddy whose average length of the full brown rice grain is above 6.5 millimeters
Slender grains – paddy with whole milled rice grain having length/width ratio over 3.0

4.4.2 Quantity to be supplied

The amount of test material to be supplied shall be sufficient for at least three hours and fifteen minutes of continuous hulling operation. Three test trials shall be conducted with minimum duration of one hour per trial. The excess amount shall be used for running-in prior to the actual conduct of test trials.

4.4.3 Test material to be used

Test materials prepared to be used for the running-in and for each test trial shall be the same.

4.5 Running-in and preliminary adjustment

Before the start of the test, the rice huller should have undergone a running-in period wherein the adjustments of the rubber roll shall be made according to the recommendation of the manufacturer.

4.6 Termination of test

If during the test run, the rubber roll fails due to manufacturing defects such as loosely bonded rubber, flaking of the rubber, vibration due to the imbalance of the rubber roll, the test shall be terminated by the test engineer.

5 Test and Inspection

5.1 Verification of the manufacturer's technical data and information

The specifications claimed by the manufacturer and the physical details given in Annex B shall be verified by the official testing agency.

5.2 Quality test

Quality test is performed to ascertain whether the rubber roll is capable of being used under practical condition. The items to be inspected are given in Annex C.

5.2.1 Dynamic balance test

This test shall be conducted to determine if the rubber roll on test is dynamically balance using a Dynamic Balancing Machine.

5.2.2 Hardness test

This test shall be conducted using a Durometer Hardness Tester or any similar testing instrument. The measurement shall be taken at twenty points randomly selected on the surface of the rubber roll.

5.2.3 Heating test

Sample particles shall be taken out from the rubber and its hardness shall be measured using a Durometer Hardness Tester. The rubber roll particles shall be put in the air oven for 1 h or 2 h under $80\text{ }^{\circ}\text{C} \pm 2\text{ }^{\circ}\text{C}$ and immediately after taking out the sample from the air oven, hardness of the particles shall be measured.

NOTE Care must be observed for temperature change at the time of measurement.

5.2.4 Measurement of specific gravity

The measurement of specific gravity shall be conducted using a hydrometer.

5.3 Performance test

5.3.1 This is carried out to obtain actual data on rubber roll performance, operating accuracy, work quality and adaptability to various paddy varieties for at least 2 h of continuous operation or until there is a 50 % reduction in the thickness of the rubber roll on test.

5.3.2 Initial data shall be collected before the test such as thickness of rubber roll and its initial clearance.

5.3.3 The test shall be conducted for at least two test trials.

5.3.4 Start the test run and record the speed (rpm) of both rubber rolls with and without load. One roll should rotate 25 % faster than the other.

5.3.5 Feed the huller evenly by adjusting the feed regulating valve in such a way that it will not cause clogging.

5.3.6 Check the huller output by inspection from time to time.

5.3.7 Clearance adjustment between the two hullers should be maintained at about $\frac{1}{2}$ the thickness of the paddy/rough rice. Adjust and record the clearance of the rubber rolls before and after each test trial.

5.3.8 Record the changes in rubber roll dimension and weight every 2 h of continuous operation. Weigh and record the amount of paddy processed.

5.3.9 Record sheet for all data and information during the test is given in Annex D.

5.3.10 Sampling and sample handling

5.3.10.1 Sampling for paddy input

The conditions of the paddy input such as bulk density, moisture content, purity and percentage cracked grains to be used in each test shall be taken using three “representative samples” each weighing 1 kg which represent the different conditions of paddy input in the bulk. This is done by randomly taking samples from the bulk. Half (500g) of the 1 kg sample shall be used for laboratory analysis and the other half (500 g) shall be used for reference purposes or for an eventual second check in case of review.

5.3.10.2 Sampling from huller outlet

During each test trial, three samples each weighing 200 g shall be randomly collected from the huller to be analyzed in the laboratory for the determination of hulling efficiency. Half (100 g) of the 200 g sample shall be used for laboratory analysis and the other half (100 g) shall be used for reference purposes or for an eventual second check in case of review.

5.3.10.3 Handling of samples

All samples to be taken to the laboratory shall be placed in appropriate containers and properly labeled. If the sample is to be used for determining moisture content, it must be kept in dry and airtight containers.

6 Laboratory analysis

6.1 Laboratory analysis of input paddy

The steps in determining the grain parameters are shown in Annex E.

6.1.1 Purity

Each of the three 500 g test paddy sample is cleaned and the components namely, the paddy and the impurities (foreign matters and weed seeds), are separated for weighing.

6.1.2 Moisture content

Five samples shall be taken for moisture content determination using a calibrated moisture meter. The mean moisture content from samples shall be taken as the moisture content of the paddy.

6.1.3 Cracked grains

Three 100 whole head grain sample is drawn for hand hulling to determine the percentage cracked brown rice. Each grain shall be hulled carefully by hand, taking care not to use undue rubbing force or high pressure to minimize mechanical stress on the grain. Each hulled grain or brown rice grains shall be examined for cracks under a magnifying lens against a backlight through a translucent plate or light diffuser. Grains which show cracks or which have been broken in the process of hand hulling shall be counted as cracked grains. The mean value

determined from the three 100 grain samples shall be taken as the percentage cracked hand-hulled brown rice.

6.2 Laboratory analysis of samples from laboratory huller and from the outlet of the rubber roll on test

6.2.1 Coefficient of hulling

Three 100 g samples from the huller output shall be separated manually into brown rice and unhulled paddy to determine the coefficient of hulling.

6.2.2 Coefficient of wholeness

Three 100 g samples of brown rice are drawn and separated into broken brown rice and whole brown rice. The coefficient of wholeness is determined from the weight of the components and shall be taken as the mean of the three samples.

6.3 Items to be determined and measured are given in Annex F and the formulas to be used during calculations and testing are given in Annex G.

7 Test reports

7.1 Name of testing agency

7.2 Test report number

7.3 Title

7.4 Summary

7.5 Purpose and scope of test

7.6 Methods of test

7.7 Table 1 – Rubber roll specifications

7.8 Table 2 –Performance test data

7.9 Observations (include pictures)

7.10 Name, signature and designation of test engineers

Annex A
(informative)

**Minimum List of Field and Laboratory
Test Equipment and Materials**

A.1	Equipment	Quantity
A.1.1	Field	
A.1.1.1	Grain moisture meter (Capacitance or conductance type) Range: 6% to 24% or 6% to 30%	1
A.1.1.2	Set of Feelers	1
A.1.1.3	Tachometer (contact or photoelectric type) Range: 0 rpm to 5,000 rpm	1
A.1.1.4	Timers Range: 60 minutes; Accuracy: 1/10 sec	1
A.1.1.5	Tape measure	2
A.1.1.6	Camera	1
A.1.2	Laboratory	
A.1.2.1	Weighing scale (Sensitivity: 0.1 g)	1
A.1.2.2	Dynamic balancing machine	1
A.1.2.3	Durometer hardness tester	1
A.1.2.4	Hydrometer	1
A.1.2.5	Magnifying lens (minimum of 10 magnifications)	1
A.1.2.6	Grain sample cleaner	1
A.1.2.7	Caliper, metric	1
A.1.2.8	Indented trays	
A.2	Materials	
A.2.1	Field	
A.2.1.1	Sample bags	1
A.2.1.2	Labeling tags which include	20
A.2.1.2.1	Date of test	
A.2.1.2.2	Rubber roll on test	
A.2.1.2.3	Sample source	
A.2.1.5.3	Variety	
A.2.1.5.4	Trial number	

Annex B
(informative)

Specifications of the Rubber Roll

Name of Applicant (or Distributor): _____

Address: _____

Telephone No: _____

Name of Factory/Distributor: _____

Address: _____

GENERAL INFORMATION

Make: _____ Model: _____

Serial No: _____ Classification: _____

Production date of rubber roll to be tested: _____

Item to be inspected:

ITEMS	Manufacturer's Specifications	Verification by the Testing Agency
B.1 Physical properties		
B.1.1 Hub material		
B.1.2 Hardness		
B.1.3 Color		
B.2 Dimensions and weight		
B.2.1 Width, mm		
B.2.2 Outside diameter, mm		
B.2.3 Inside diameter, mm		
B.2.4 Thickness, mm		
B.2.5 Core diameter, mm		
B.2.6 Weight, kg		
B.3 Labeling		
B.3.1 Trade mark		
B.3.2 Country of manufacture		
B.3.3 Type		
B.3.4 Size, W x D, mm x mm		

B.4 Diagram of the rubber roll

B.4.1 Centered

A	Width	G	Rim Diameter
B	Outside Diameter	H	Bolt Circle Diameter
C	Inside Diameter	I	Bolt Diameter
D	Rubber Thickness	J	Shorter Length of Web
E	Bore	K	Web Thickness
F	Rim Thickness	L	Longer Length of web

NOTE: ALL DIMENSIONS IN MILLIMETER

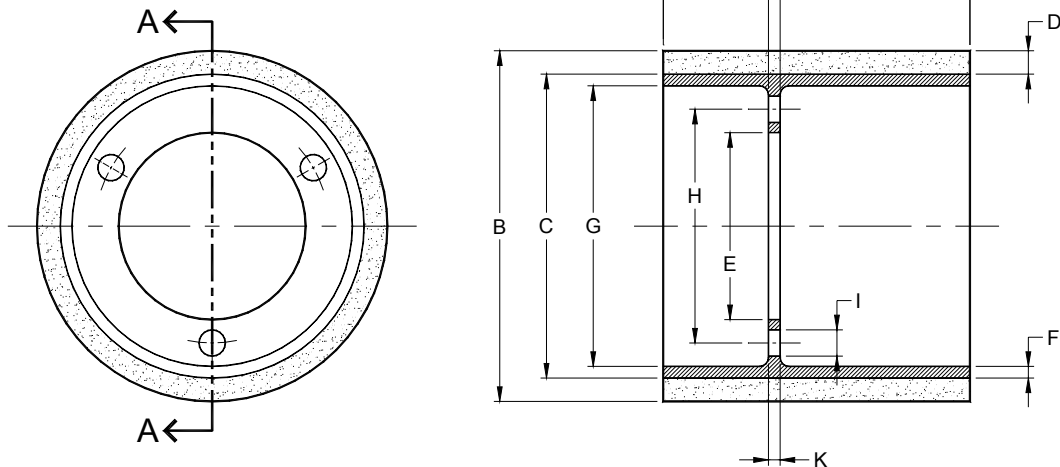

SECTION A-A

ITEMS	Manufacturer's Specifications	Verification by the Testing Agency
B.4.1.1 Width (mm), A		
B.4.1.2 Outside diameter (mm), B		
B.4.1.3 Inside diameter (mm), C		
B.4.1.4 Rubber thickness (mm), D		
B.4.1.5 Bore (mm), E		
B.4.1.6 Rim thickness (mm), F		
B.4.1.7 Rim diameter (mm), G		
B.4.1.8 Bolt circle diameter (mm), H		
B.4.1.9 Bolt diameter (mm), I		
B.4.1.10 Shorter length of web (mm), J		
B.4.1.11 Web thickness (mm), K		
B.4.1.12 Longer length of web (mm), L		

B.4.2 Off-centered

A	Width	G	Width of Key
B	Outside Diameter	H	Height of Key
C	Inside Diameter	I	Distance of Screw Holes
D	Rubber Thickness	I	Distance to Edge
E	Rim Diameter	J	Center to Center Distance
F	Rim Thickness	J	of Screw Holes

NOTE: ALL DIMENSIONS IN MILIMETER

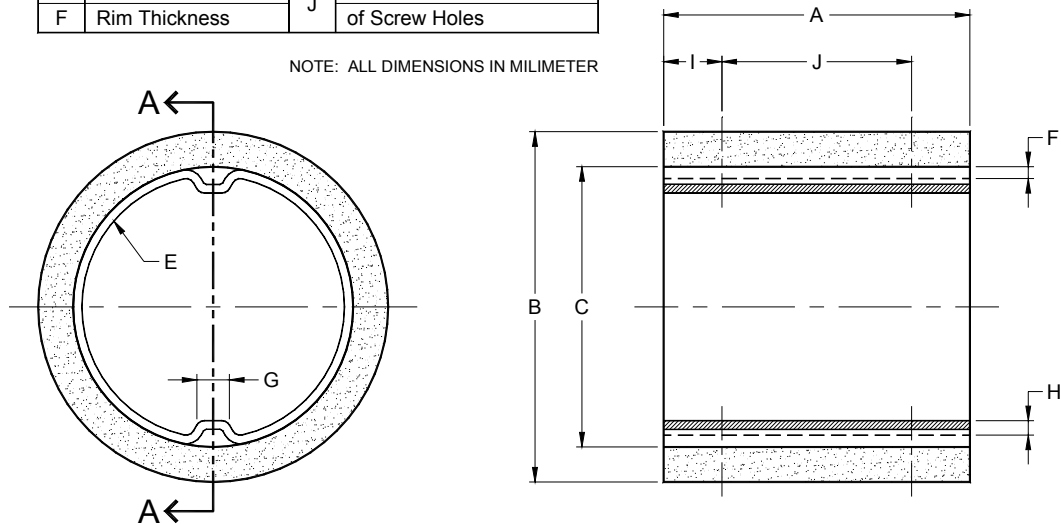

SECTION A-A

ITEMS	Manufacturer's Specifications	Verification by the Testing Agency
B.4.2.1 Width (mm), A		
B.4.2.2 Outside diameter (mm), B		
B.4.2.3 Inside diameter (mm), C		
B.4.2.4 Rubber thickness (mm), D		
B.4.2.5 Rim diameter (mm), E		
B.4.2.6 Rim thickness (mm), F		
B.4.2.7 Width of key (mm), G		
B.4.2.8 Height of key (mm), H		
B.4.2.9 Distance of screw holes from rim to edge (mm), I		
B.4.2.10 Center to center distance of screw holes (mm), J		

Annex C
(informative)

Quality Test Data Sheet

Test Engineer: _____
 Assistants: _____
 Test Requested by: _____
 Test Specimen: _____

Date: _____
 Location: _____
 Manufacturer: _____

C.1 Dynamic Balancing Test

	Trial 1	Trial 2	Trial 3	Average
C.1.1 Valve				
C.1.2 Angle of balance				

C.2 Durometer Hardness Test

Average				

C.3 Heating Test

Average				

C.4 Specific Gravity

Average				

Annex D
(informative)

Performance Test Data Sheet

Test Engineer: _____
 Assistants: _____
 Test Requested by: _____
 Test Specimen: _____

Date: _____
 Location: _____
 Manufacturer: _____

Items to be measured and inspected:

Items	Trial 1	Trial 2	Average
D.1 Conditions of test sample			
D.1.1 Variety			
D.1.2 Moisture content, %			
D.2.1 Rubber rolls clearance, mm			
D.2.1.1 Initial			
D.2.1.2 Final			
D.2.2 Speed, rpm			
D.2.2.1 Rubber roll 1			
D.2.2.1.1 Without load			
D.2.2.1.2 With load			
D.2.2.2 Rubber roll 2			
D.2.2.2.1 Without load			
D.2.2.2.2 With load			
D.2.3 Hulling time, h			
D.2.4 Hulling rate, t/h			
D.2.5 Hulling efficiency, %			
D.2.6 Temperature, °C			
D.2.6.1 Rubber roll 1			
D.2.6.2 Rubber roll 2			

Annex E
(informative)

Standard Laboratory Method in Assessing Hulling Performance of Paddy Huller

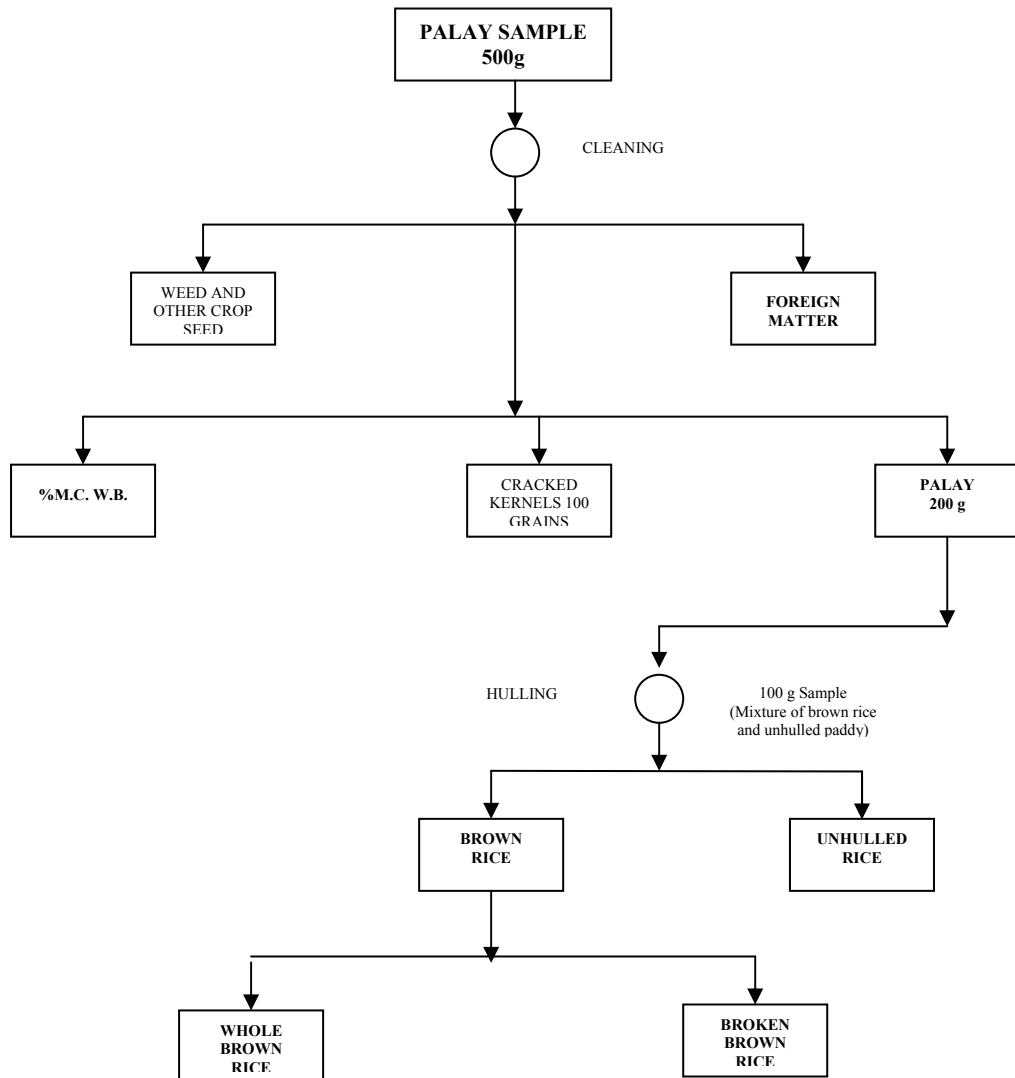

Figure 1 - Standard laboratory method in assessing hulling performance of paddy huller

Annex F
(informative)

Laboratory Test Data Sheet

Item	Trial			Average
	1	2	3	
F.1 Test paddy				
F.1.1 Purity, %				
F.1.2 Moisture content, %, wet basis				
F.1.3 Foreign matter and weed seeds, g				
F.1.4 Cracked hand-hulled brown rice, %				
F.2 Sample from rubber roll tested				
F.2.1 Weight brown rice, g				
F.2.1.1 Weight of whole brown rice, g				
F.2.1.2 Weight of broken brown rice, g				
F.2.2 Weight of unhulled paddy, g				
F.2.3 Coefficient of hulling				
F.2.4 Coefficient of wholeness				
F.2.5 Hulling efficiency, %				
F.3 Sample from laboratory huller				
F.3.1 Weight brown rice, g				
F.3.1.1 Weight of whole brown rice, g				
F.3.1.2 Weight of broken brown rice, g				
F.3.2 Weight of unhulled paddy, g				
F.3.3 Coefficient of hulling				
F.3.4 Coefficient of wholeness				
F.3.5 Hulling efficiency, %				

Annex G
(informative)

Formulas used during calculations and testing

G.1 Coefficient of hulling

$$e_h = 1 - \frac{W_u}{W_s}$$

where:

e_h	=	Coefficient of hulling
W_u	=	Weight of unhulled paddy, g
W_s	=	Weight of sample (mixture of brown rice and unhulled paddy), g

G.2 Coefficient of wholeness

$$e_w = \frac{W_w}{W_T}$$

where:

e_w	=	Coefficient of wholeness
W_w	=	Weight of whole brown rice in the sample, g
W_T	=	Weight of the total brown rice hulled (whole and broken), g

G.3 Hulling efficiency

$$E_h = e_h e_w$$

where:

E_h	=	Hulling efficiency, %
e_h	=	Coefficient of hulling
e_w	=	Coefficient of wholeness

G.4 Hulling capacity

$$H_c = \frac{H_o e_h}{T_o}$$

where:

H_c	=	Hulling capacity, kg/h
H_o	=	Total huller output, kg
e_h	=	Hulling coefficient
T_o	=	Operating time, h