

## **Foreword**

The formulation of this national standard was initiated by the Agricultural Machinery Testing and Evaluation Center (AMTEC) with support from the Department of Agriculture.

This standard has been technically prepared in accordance with BPS Directives Part 3:2003 – Rules for the Structure and Drafting of International Standards.

The word “shall” is used to indicate requirements strictly to be followed in order to conform to the standard and from which no deviation is permitted.

The word “should” is used to indicate that among several possibilities one is recommended as particularly suitable, without mentioning or excluding others, or that certain course of action is preferred but not necessarily required.

In the preparation of this standard, the following documents/publications were considered:

AMTEC Test and Evaluation Reports for Root Crop Chipper and Slicer.

ISO 11448:1997(E), Powered Shredders and Chippers – Definitions, Safety Requirements and Test Procedures.

---

**Agricultural Machinery – Chipping Machine – Specifications**

---

**1 Scope**

This standard specifies the requirements for the construction and performance for power-driven and manually-operated chipping machine for root crops and banana.

**2 References**

The following normative documents contain provisions, which, through reference in this text, constitute provisions of this National Standard:

**PAES 102: 2000** Agricultural Machinery – Operator’s Manual – Content and Presentation

**PAES 103:2000** Agricultural Machinery – Method of Sampling

**PAES 223:2004** Agricultural Machinery – Chipping Machine – Methods of Test

**3 Definitions**

For the purpose of this standard the following definitions shall apply:

**3.1****chip**

thin slice of material with thickness of about 4 mm

**3.2****chipping machine****chipper**

size reduction machine either power or manually operated which is used to cut or slice root crops or banana into small thin pieces called chips (see Figure 1)

**3.3****chipping capacity**

amount of material that can be processed per unit time, kg/h

**3.4****cutterhead**

cutting rotor

devices intended to slice the crop into chips with reasonable consistency within a range of optional settings

**3.5****discharge chute**

opening through which chipped material is thrown out

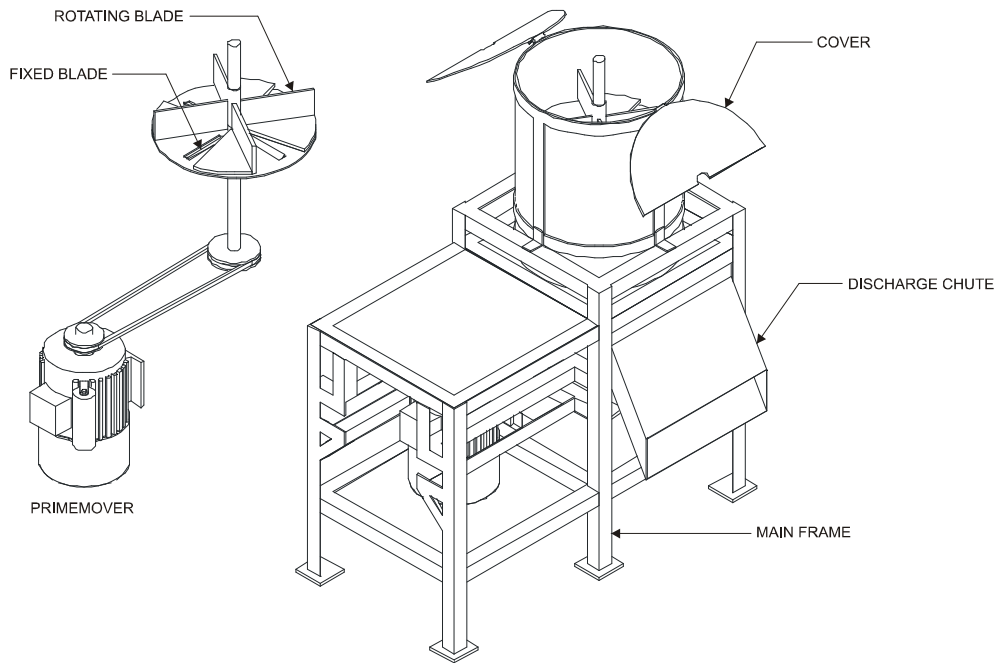

**Figure 1 – Typical design of a chipping machine**

**3.6  
flywheel type**

type of chipping machine with knives mounted radially with the cutting edges describing a plane perpendicular to the axis of rotation (see Figure 2)

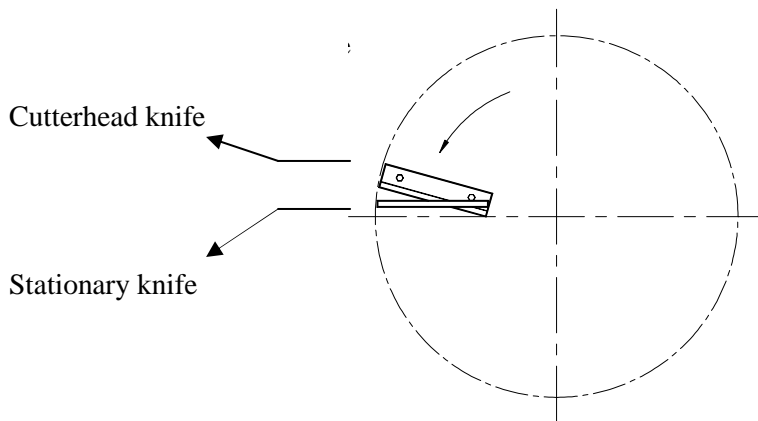

**Figure 2 – Flywheel type**

**3.7  
guard**

component intended to provide protection for the operator or bystander from injury

### 3.8 drum type

knives on cylindrical mountings such that the cutting edges of the knives are essentially parallel to the axis of rotation (see Figure 3)

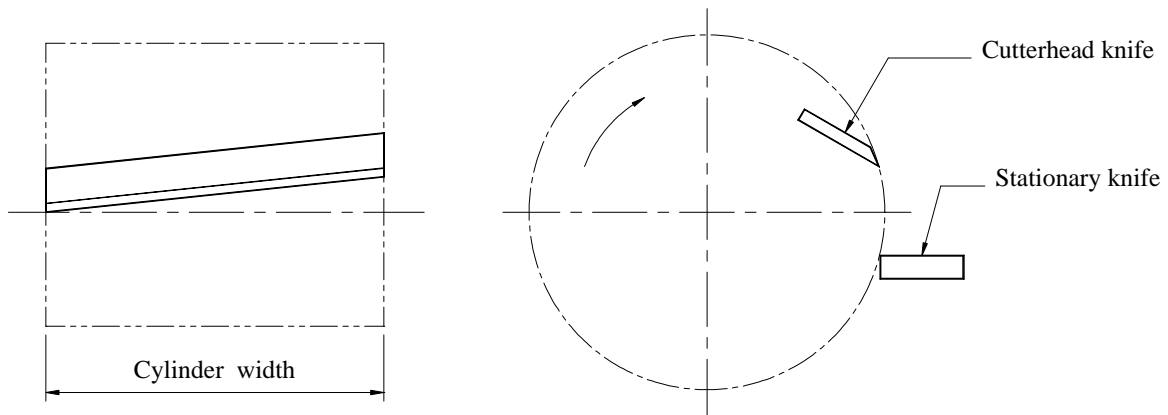

**Figure 3 – Cylinder cutterhead**

## 4 Classification

The classification of chipping machine shall be based according to the following:

- 4.1 Based on primemover
  - 4.1.1 Power-operated
  - 4.1.2 Manually-operated
- 4.2 Based on chipping mechanism
  - 4.2.1 Flywheel type
  - 4.2.2 Drum type

## 5 Materials of Construction

5.1 Steel bars and metal sheet or plate shall be generally used in the manufacture of the different components of chipping machine. However, for parts which are in direct contact with the materials to be chipped, food grade materials shall be used.

5.2 Chipping elements should be made of either AISI 1040 to AISI 1045 or its ISO equivalent.

## 6 Performance Requirements

The chipping machine when tested in accordance with PAES 223 shall conform to the following requirements:

**6.1** Chipping machine shall be able to cut at least three different thickness settings with 5% maximum variation of cut.

**6.2** The chipping machine shall produce a clear-cut chipped material.

**6.3** The noise emitted by the chipping machine shall not be more than 92 db (A)\*.

## 7 Design, Construction and Workmanship

**7.1** To safeguard against contact with the cutting mechanism, the machines shall be constructed to meet the requirements given in Tables 1 and 2.

**Table 1 – Safety distances from feed opening less than 250 mm**

Dimensions in millimeters

Feed opening size <sup>1</sup>	Feed opening shape		
	slot	square	Round
$\leq 40$	$\geq 200$	$\geq 200$	$\geq 120$
$> 40 \leq 50$	$\geq 850^{2,3}$	$\geq 200$	$\geq 200$
$> 50 \leq 250$	$\geq 850^3$	$\geq 850^3$	$\geq 850^3$

1. Measured across the narrowest point.  
 2. If the length of the slot opening measured along the side of the slot is  $\leq 65$  mm, the safety distance can be reduced to 200 mm.  
 3. Where the height of the lowest outer of any barrier or the feed opening itself is  $\geq 1,200$  mm above the ground, the safety distance is measured as a chain measurement from the outer edge. Openings  $< 1,200$  mm above the ground are measured as the shortest distance from the plane of the opening. If the opening is more than 1,200 mm above the ground, this safety distance to the cutting means can be reduced by  $L/2$  where  $L = h - 1,200$  and  $h$  is the height above the ground of the lowest point of the feed opening.

**Table 2 – Safety distances from feed opening greater than 250 mm**

Dimensions in millimeters

Height above the ground at the lowest edge of the feed opening	Distance to the cutting means from the edge of the feed opening
$\leq 1200$	$\geq 1200^1$
$\geq 1200$	$\geq 850^2$

1. Where the height of the lowest edge of the opening is below 1,200 mm, the chute shall be restricted to not more than 400 mm x 400 mm at the distance of at least 850 mm from the cutting means and the actual opening shall measure no more than 1,000 mm in any direction.  
 2. Where the height of the lowest outer edge of any barrier or the feed opening itself is  $\geq 1,200$  mm above the ground, the safety distance is measured as a chain measurement from the outer edge. Openings  $< 1,200$  mm above the ground are measured as the shortest distance from the plane of opening. If the opening is more than 1,200 mm above the ground, this safety distance to the cutting means can be reduced by  $L/2$  where  $L = h - 1200$  and  $h$  is the height above the ground of the lowest point of the feed opening.

\* Allowable noise level for six (6) hours of continuous exposure based on Occupational Safety and Health Standards, Ministry of Labor, Philippines. 1983.

**7.2** The discharge chute shall be designed so as to prevent direct access to and accidental contact with the cutting elements.

**7.3** The chipping machine shall be free from manufacturing defects that may be detrimental to its operation.

**7.4** The chipping machine shall be free from sharp edges and surfaces (except for the cutting edge) that may injure the operator.

**7.5** Guards allowing access to the cutting chamber shall be interlocked to cause the moving parts to come to rest before access can be gained. Other guards (i.e. belt cover) shall be permanently attached to the machine and shall not be detachable without the use of tools.

**7.6** Rotating parts should be dynamically balanced.

**7.7** Mechanism for immediate disengagement of power transmission shall be provided.

**7.8** Sealed type bearings should be used as protection against dust. There shall be provision for lubrication of non-sealed type bearings and bushings.

**7.9** Belt tightening and adjustments shall be provided.

**7.10** Any uncoated metallic surfaces shall be free from rust and shall be painted properly.

## **8 Warranty for Construction and Durability**

**8.1** Warranty against defective materials and workmanship shall be provided for parts and services except for the normal wear and tear of consumable maintenance parts such as belts within six months from the purchase of the chipping machine.

**8.2** The construction shall be rigid and durable without breakdown of its major components (i.e. transmission systems, etc) within six months from date of original purchase.

## **9 Maintenance and Operation**

**9.1** Each chipping machine unit shall be provided with a set of manufacturer's standard tools required for maintenance.

**9.2** An operator's manual, which conforms to PAES 102, shall be provided.

## **10 Sampling**

The chipping machine shall be sampled for testing in accordance with PAES 103.

## **11 Testing**

Sampled chipping machine shall be tested in accordance with PAES 221.

## **12 Marking and Labeling**

**12.1** Each chipping machine shall be marked in English with the following information using a stencil or by directly punching it in a plate and shall be positioned at the most conspicuous place:

**12.1.1** Registered trademark of the manufacturer

**12.1.2** Brand

**12.1.3** Model

**12.1.4** Serial number

**12.1.5** Chipping capacity, kg/h

**12.1.6** Power requirement, kW

**12.1.7** Name and address of the manufacturer

**12.1.8** Name and address of the importer, if imported

**12.1.9** Country of manufacture (if imported) / “Made in the Philippines” (if manufactured in the Philippines)

**12.2** Safety/precautionary markings shall be provided when appropriate. Marking shall be stated in English and Filipino and shall be printed in red color with a white background.

**12.3** The markings shall have a durable bond with the base surface material.

**12.4** The markings shall be weather resistant and under normal cleaning procedures, it shall not fade, discolor, crack or blister and shall remain legible.