

PHILIPPINE NATIONAL STANDARD

PNS/PAES 147:2010
(PAES published 2010)
ICS 65.060.01

Agricultural machinery – Field cultivator – Specifications



BUREAU OF PRODUCT STANDARDS

Member to the International Organization for Standardization (ISO)
Standards and Conformance Portal: www.bps.dti.gov.ph

National Foreword

This Philippine Agricultural Engineering Standards PAES 147:2010, Agricultural machinery – Field cultivator – Specifications was approved for adoption as Philippine National Standard by the Bureau of Product Standards upon the recommendation of the Agricultural Machinery Testing and Evaluation Center (AMTEC) and the Philippine Council for Agriculture, Forestry and Natural Resources Research and Development of the Department of Science and Technology (PCARRD-DOST).

Foreword

The formulation of this national standard was initiated by the Agricultural Machinery Testing and Evaluation Center (AMTEC) under the project entitled “Development of Standards for Agricultural Production and Postharvest Machinery” funded by the Philippine Council for Agriculture, Forestry and Natural Resources Research and Development - Department of Science and Technology (PCARRD-DOST).

This standard has been technically prepared in accordance with BPS Directives Part 3:2003 – Rules for the Structure and Drafting of International Standards.

The word “shall” is used to indicate mandatory requirements to conform to the standard.

The word “should” is used to indicate that among several possibilities one is recommended as particularly suitable without mentioning or excluding others.

In the preparation of this standard, the following documents/publications were considered:

ABT 49 Field Equipment Operation

American Society of Agricultural Engineers S414.1 – Terminology and Definitions for Agricultural Tillage Implements

United States Patents 4195697

United States Patents 5161622

Grubinger, V. Cultivation equipment for weed control: pros, cons and sources. University of Vermont Extension.

<http://www.sare.org/publications/steel/glossary.htm>

<http://www.indiamart.com/gs-auto/agricultural-implements.html>

<http://www.steelforge.com/alloysteels.htm>

http://www.efunda.com/materials/alloys/alloy_steels/show_alloy.cfm?ID=AISI_5160&show_prop=all&Page_Title=AISI%205160

[www1.agric.gov.ab.ca/\\$department/deptdocs.nsf/all/eng9916/\\$file/746.PDF?](http://www1.agric.gov.ab.ca/$department/deptdocs.nsf/all/eng9916/$file/746.PDF?OpenElement)
OpenElement – http://zj.shuidao.cn/IRRI/landPrep/Landprep_lesson04.htm

Agricultural Machinery – Field Cultivator – Specifications

1 Scope

This standard specifies the manufacturing and performance requirements for two-wheel tractor driven and four-wheel tractor driven field cultivator.

2 References

The following normative documents contain provisions, which through the reference in this text, constitute provisions of this National Standard:

AWS D1.1:2000	Structural Welding Code - Steel
PAES 102: 2000	Agricultural Machinery – Operator’s Manual – Content and Presentation
PAES 106:2000	Agricultural Machinery – Soil Tillage and Equipment – Terminology
PAES 118: 2001	Agricultural Machinery – Four-Wheel Tractor – Specifications
PAES 148:2010	Agricultural Machinery – Field Cultivator – Methods of Test

3 Definitions

For the purpose of this standard, the definitions given in PAES 106 and the following definitions shall apply:

3.1**field cultivator**

implement for seedbed preparation, weed eradication, or fallow cultivation subsequent to some form of primary tillage, equipped with spring steel shanks (Fig. 1)

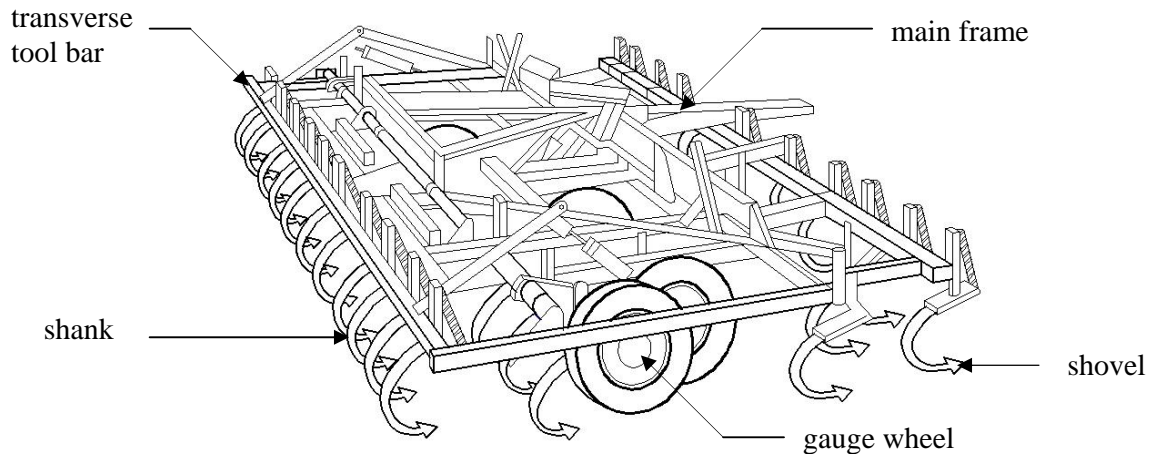

Figure 1. Field cultivator

3.2

gauge wheel

auxiliary component of the field cultivator that helps maintain uniform depth of cultivation and eliminate the need to set the tension with the three-point hitch every time you set a cultivator down (Fig. 1)

3.3.

ground clearance

minimum vertical distance between the soil surface and a potentially obstructing machine element

3.4

main frame

part of the field cultivator that holds the transverse toolbars and gauge wheels together (Fig. 1)

3.5

primary tillage

tillage which constitutes the initial major soil-working operation, normally designed to reduce soil strength, cover plant materials, and rearrange aggregates

3.6

secondary tillage

any group of different tillage operation, following primary tillage, which are designed to create refined soil conditions before the seed is planted

3.7

shank

structural member primarily used for attaching a tillage tool to a beam (Fig. 1)

3.8

shovel

spade-shaped, V-pointed soil working tool, which is used for various plowstocks, cultivators, grain drills, and soil scarifiers (Fig. 1)

3.9

spike

type of shovel used in hard soil conditions and for deeper penetration (Fig. 2)



Figure 2. Spike type shovel

3.10

sweep

type of shovel which is wing-shaped (Fig. 3)

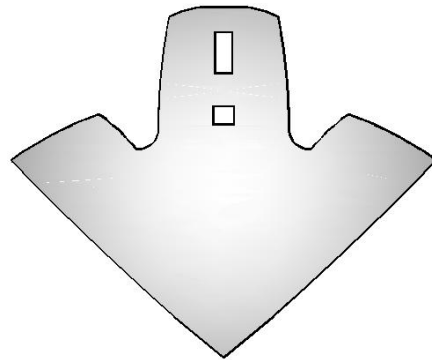

Figure 3. Sweep type shovel

3.11

transverse tool bar

part of the main frame to which shank assemblies are attached (Fig. 1)

4 Classification

4.1 According to type of driving tractor

4.1.1 Two-wheel tractor driven

Type of field cultivator wherein a two-wheel tractor is used to drive the soil tool (Fig. 4).

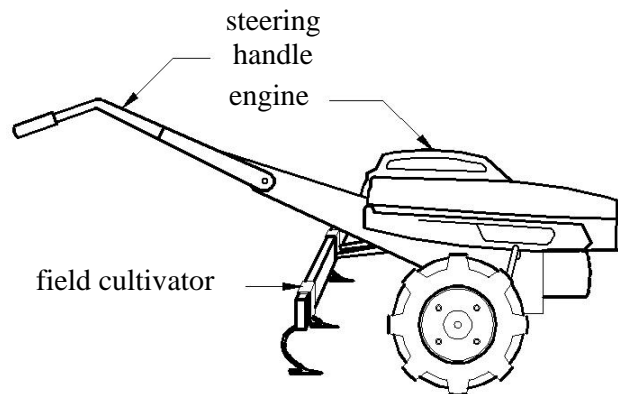

Figure 4. Two-wheel tractor driven field cultivator

4.1.2 Four-wheel tractor driven

Type of field cultivator wherein a four-wheel tractor is used to drive the soil tool (Fig. 5-7a).

4.2 According to type of mounting

4.2.1 Rear mounted

Type of field cultivator wherein the implement is mounted behind the tractor.

4.2.1.1 Drawn type cultivator

Type of field cultivator wherein main frame is mounted far behind the tractor. Guide wheels are necessary for transport (Fig. 5).

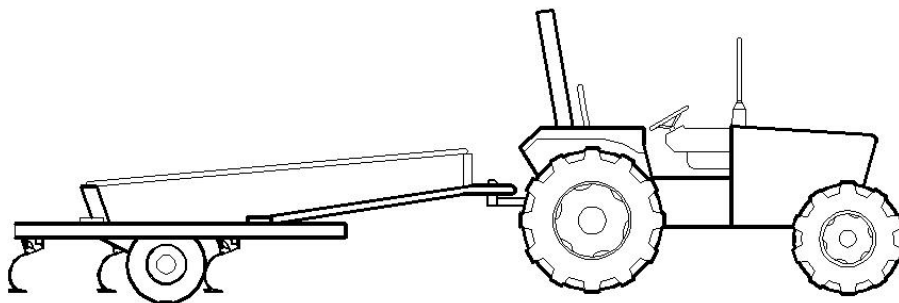

Figure 5. Drawn type cultivator

4.2.1.2 Three-point hitch mounted

Type of field cultivator wherein main frame is mounted to the rear of the tractor using the three-point hitch linkages (Fig. 6).

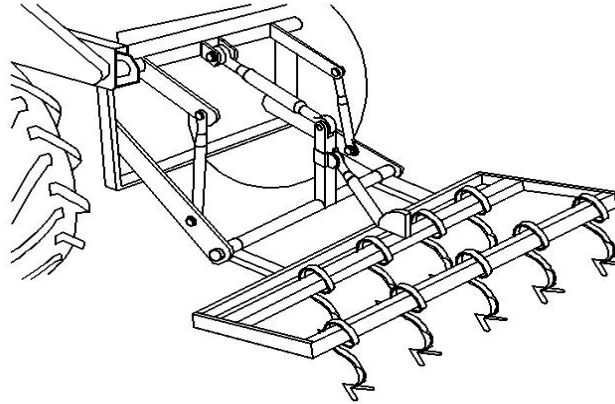

Figure 6. Three-point hitch mounted cultivator

4.2.2 Front mounted

Type of field cultivator wherein main frame is mounted on the front of the tractor. For a four-wheel driven type, hydraulic cylinders are required for lowering or lifting of the implement (Fig. 7a). Gauge wheels are used for adjusting the depth for a two-wheel driven type (Fig. 7b).

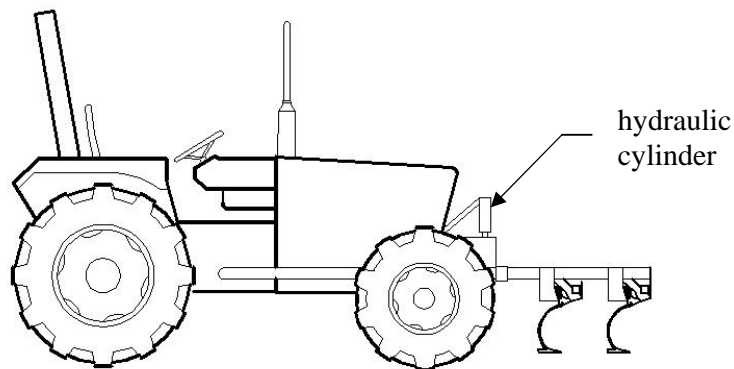

Figure 7a. Front mounted cultivator (four-wheel tractor driven).

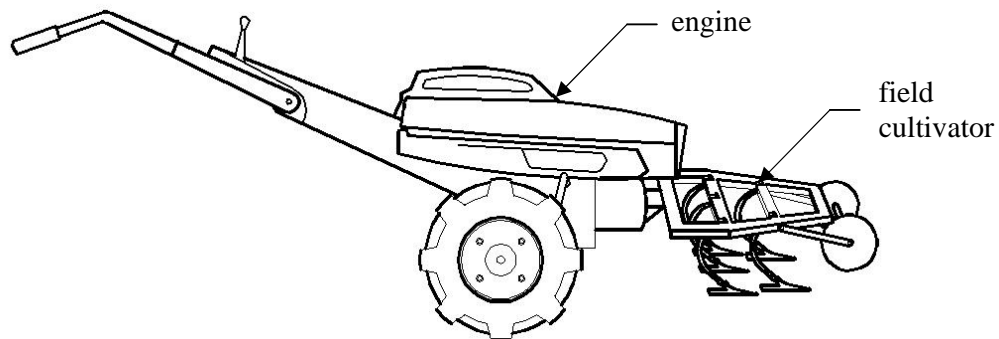

Figure 7b. Front mounted cultivator (two-wheel tractor driven).

4.3 According to type of shank

4.3.1 “C”- shaped shank or C-shank

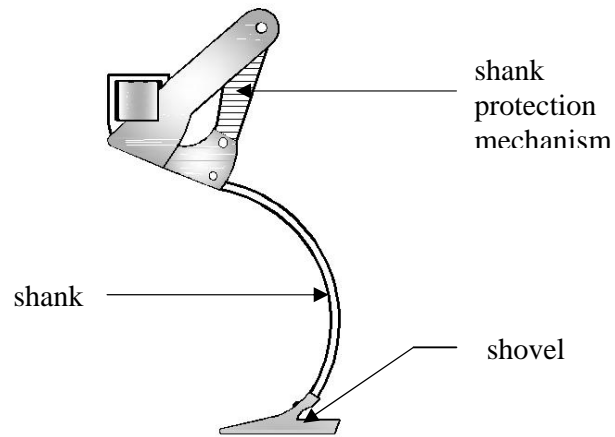

Figure 8. C-shank.

4.3.2 “S” or “K”- tine shank

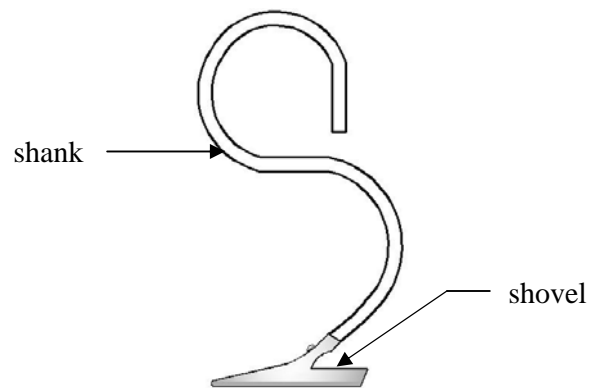

Figure 9. S-tine shank.

5 Principle of Operation

The field cultivator shall be mounted on the tractor. After being transported to the field, the implement shall be lowered on the soil. The desired operating depth shall be set by adjusting the gauge wheels or through the action of hydraulic cylinders. The field cultivator shall be pulled or pushed by the tractor to cut through the soil.

6 Manufacturing Requirements

Generally, the field cultivator shall consist of main frame, transverse tool bars and shank assembly.

6.1 The main frame and the transverse toolbars shall be made of mild steel (e.g. AISI 1020). These shall be constructed from 76 mm x 102 mm (3” x 4”)

square tube or channel bar or from a 76 mm angular bar with at least 6 mm thickness for four-wheel tractor driven types.

- 6.2** For two-wheel tractor driven types, the main frame and the transverse toolbars shall be constructed from 51 mm x 6 mm (2" x ¼ ") flat bar.
- 6.3** The main frame shall have a provision for attaching to the tractor as specified in PAES 118. Frame sections shall be folded to facilitate ease of transport.
- 6.4** The shank assembly shall consist of shank, shank protection mechanism, and shovels.
 - 6.4.1** Shanks shall be made of alloy steel (e.g. AISI 5160) with at least 5 mm (3/16") thickness. Shanks shall be spaced 152 mm to 229 mm (6" to 9") in a staggered pattern. It shall be attached to the frame by bolt or shall be fully welded. C-shank shall have a 610 mm (24") ground clearance. S-tine shall have a ground clearance of 508 mm (20").
 - 6.4.2** Shanks shall have a "C" or "S" shape to provide a spring effect when encountering obstructions. It shall have a stem angle of 41 degrees to 52 degrees.
 - 6.4.3** Holes shall be punched at the ends of the shanks where the shovels or spikes shall be attached.
 - 6.4.4** The shovel shall be made of heat-treated carbon (e.g. AISI 1080). It shall be bolted on the end of the shanks to allow replacement. It shall have a thickness of at least 5 mm (3/16"). Sweeps shall have a nose angle of 41 degrees to 52 degrees.
 - 6.4.5** Steel springs shall be integrated with the shank assembly to provide protection for the shank during tillage.
- 6.5** Gauge wheels should have an adjustable axle to allow modification of operating depth.
- 6.6** All welded parts shall be in accordance with the criteria set in AWS D1.1:2000.
 - 6.6.1** There shall be no crack on welded area.
 - 6.6.2** There shall be fusion between adjacent layers of weld metal and between weld metal and base metal.
 - 6.6.3** All craters shall be filled to provide the specified weld size, except for the end of intermittent fillet welds outside of their effective length.
 - 6.6.4** Weld profiles shall be in its acceptable form.
 - 6.6.5** Welded joints shall not be less than 4 mm site fillet weld.

6.6.6 Undercut shall not exceed 2 mm for any length of weld.

7 Performance Requirements

7.1 The field cultivator shall have an operating depth of 51 mm to 152 mm (2” to 6”).

7.2 There shall be a uniform depth of cut on the soil.

7.3 There shall be at least 80% field efficiency.

7.4 The shanks shall reset to its original position after tilling operation.

7.5 The shank assembly and the gauge wheel assembly shall be intact after the test.

7.6 The hydraulic cylinder shall be able to adjust the operating depth of the field cultivator.

7.7 The field cultivator shall be able to overcome obstructions in the soil.

7.8 The field cultivator shall be easy to mount and dismount from the tractor linkages.

8 Safety, Workmanship and Finish

8.1 The field cultivator shall be painted and shall have a rust-free finish.

8.2 The field cultivator shall be free from manufacturing defects that maybe unsafe.

8.3 All bolts shall conform with standards for strength application and shall be made of hot-galvanized steel for corrosion resistance.

9 Warranty of Construction

9.1 The field cultivator’s construction shall be rigid and durable without breakdown of its major components within three (3) years from the date of original purchase.

9.2 Warranty shall be provided for parts and services within three (3) years after installation and acceptance by the consumer.

10 Maintenance and Operation

10.1 An operator's manual which conforms to PAES 102 shall be provided.

10.2 Grease points for shank protection mechanism shall be provided.

10.3 Tools for adjustment of shank assembly shall be provided.

11 Testing

Testing of the field cultivator shall be conducted on-site. The field cultivator shall be tested for performance in accordance with PAES 148.

12 Marking and Labeling

12.1 The field cultivator shall be marked in English with the following information using a plate, stencil or by directly punching it at the most conspicuous place:

12.1.1 Brand name or Registered trademark of the manufacturer

12.1.2 Model and Serial number

12.1.3 Country of manufacture (if imported)/"Made in the Philippines" (if manufactured in the Philippines)

12.2 Safety/precautionary markings shall be provided. Markings shall be stated in English or Filipino and shall be printed in red color with a white background.

12.3 The markings shall have a durable bond with the base surface material and shall be water and heat resistant under normal cleaning procedures. It shall not fade, discolor, crack or blister and shall remain legible.

12.4 Reflectors shall be attached at the rear of the cultivator for safety during transport.

Philippine Agricultural Engineering Standards

AMTEC-UPLB – PCARRD Project: “Development of Standards for Agricultural Production and Postharvest Machinery”

Technical Committee 1. Production Machinery

Chairman: Engr. Joel R. Panagsagan
Agricultural Machinery Manufacturers and Distributors Association
(AMMDA), Inc.

Members: Dr. Caesar Joventino M. Tado
Philippine Rice Research Institute (PhilRice)

Engr. Francia M. Macalintal
National Agricultural and Fishery Council (NAFC)
Department of Agriculture

Engr. Julieta T. Uriarte
Metal Industry Research and Development Center (MIRDC)
Department of Science and Technology

Engr. Angelito V. Angeles
Philippine Society of Agricultural Engineers (PSAE)

Technical Committee 2. Postharvest Machinery

Chairman: Engr. George Q. Canapi
Agricultural Machinery Manufacturers and Distributors Association
(AMMDA), Inc.

Members: Engr. Dionisio C. Coronel, Sr.
National Food Authority (NFA)
Department of Agriculture

Engr. Reynaldo P. Gregorio
Bureau of Postharvest Research and Extension (BPRE)
Department of Agriculture

Engr. Jose B. Ferrer
Metal Industry Research and Development Center (MIRDC)
Department of Science and Technology

Dr. Elmer D. Castillo
Philippine Society of Agricultural Engineers (PSAE)

your partner in product quality and safety



BUREAU OF PRODUCT STANDARDS

3F Trade and Industry Building
361 Sen. Gil J. Puyat Avenue, Makati City 1200, Metro Manila, Philippines
T/ (632) 751.3125 / 751.3123 / 751.4735
F/ (632) 751.4706 / 751.4731
E-mail : bps@dti.gov.ph
www.dti.gov.ph