

PHILIPPINE NATIONAL STANDARD

PNS/PAES 154:2010
(PAES published 2010)
ICS 65.060.01

**Agricultural machinery – Hand Pump –
Methods of Test**



BUREAU OF PRODUCT STANDARDS

Member to the International Organization for Standardization (ISO)
Standards and Conformance Portal: www.bps.dti.gov.ph

National Foreword

This Philippine Agricultural Engineering Standards PAES 154:2010, Agricultural machinery – Hand Pump – Methods of Test was approved for adoption as Philippine National Standard by the Bureau of Product Standards upon the recommendation of the Agricultural Machinery Testing and Evaluation Center (AMTEC) and the Philippine Council for Agriculture, Forestry and Natural Resources Research and Development of the Department of Science and Technology (PCARRD-DOST).

Foreword

The formulation of this national standard was initiated by the Agricultural Machinery Testing and Evaluation Center (AMTEC) under the project entitled “Development of Standards for Agricultural Production and Postharvest Machinery” funded by the Philippine Council for Agriculture, Forestry and Natural Resources Research and Development - Department of Science and Technology (PCARRD - DOST).

This standard has been technically prepared in accordance with BPS Directives Part 3:2003 – Rules for the Structure and Drafting of International Standards.

The word “shall” is used to indicate mandatory requirements to conform to the standard.

The word “should” is used to indicate that among several possibilities one is recommended as particularly suitable without mentioning or excluding others.

In the preparation of this standard, the following documents/publications were considered:

United States Patent 6694862B1

http://www.ajayindustrial.com/handp_force&lift.htm

<http://www.waterencyclopedia.com/Po-Re/Pumps-Traditional.html>

<http://www.cee.vt.edu/ewr/environmental/teach/wtprimer/pumps/pumps.html>

<http://www.steelforge.com/alloysteels.htm>

<http://www.survivalunlimited.com/waterpumps/ohandpumps.htm>

<http://www.cee.vt.edu/ewr/environmental/teach/wtprimer/pumps/pumps.html>

CONTENTS		Page
1	Scope	3
2	References	3
3	Definitions	3
4	General Conditions for Test and Inspection	5
4.1	Role of the manufacturer/dealer	5
4.2	Role of the operator	5
4.3	Test site conditions	5
4.4	Test instruments/equipment	5
4.5	Termination of test for the hand pump	6
5	Test and Inspection	6
5.1	Verification of the manufacturer's technical data and information	6
5.2	Performance test	6
5.3	Test trial	8
6	Test Report	8

ANNEXES

A	Suggested Minimum List of Test Equipment	10
B	Specifications of Hand Pump	11
C	Performance Test Data Sheet	13
D	Formula Used During Calculation and Testing	16

Agricultural Machinery – Hand Pump – Methods of Test

1 Scope

This standard specifies the methods of test and inspection for a hand pump. Specifically, it shall be used to:

1.1 verify the mechanism, dimensions, materials, accessories of the hand pump and the list of specifications submitted by the manufacturer;

1.2 determine the performance of the equipment; and,

1.3 report the results of the tests.

2 References

The following normative documents contain provisions, which through reference in this text constitute provisions of these standards:

PAES 153:2010 Agricultural Machinery – Hand Pump – Specifications

3 Definitions

For the purpose of this standard, the definitions given in PAES 153 and the following shall apply:

3.1**base plane**

center line of the pump containing the center of the plunger in its highest position

3.2**discharge rate**

volume of water pumped per unit time

3.3**friction head**

equivalent head required to overcome the friction caused by the flow through the pipe and pipe fittings

3.4**full stroke**

operation of the pump from the topmost position of the handle to its lowest position

3.5

head

quantity used to express a form (or combination of forms) of the energy content of the liquid per unit weight of the liquid referred to any arbitrary datum

3.6

overall height

measurement from the topmost part of the hand pump to the base or pedestal

3.7

overall length

measurement between extremities of the hand pump along its longer side including all protruding parts

3.8

overall width

measurement between extremities of the hand pump along its shorter side including all protruding parts

3.9

static suction head (h_1)

vertical distance from base plane of the pump to the free level of water source

3.10

static discharge head (h_2)

vertical distance from the base plane of the pump to the discharge water level

3.11

total static head (h_g)

vertical distance from suction water level to discharge water level, the sum of the static suction and discharge heads

3.12

volumetric efficiency

ratio of the actual volume of fluid discharge to that of the piston or plunger displacement in one stroke.

3.13

water power

theoretical power required for pumping

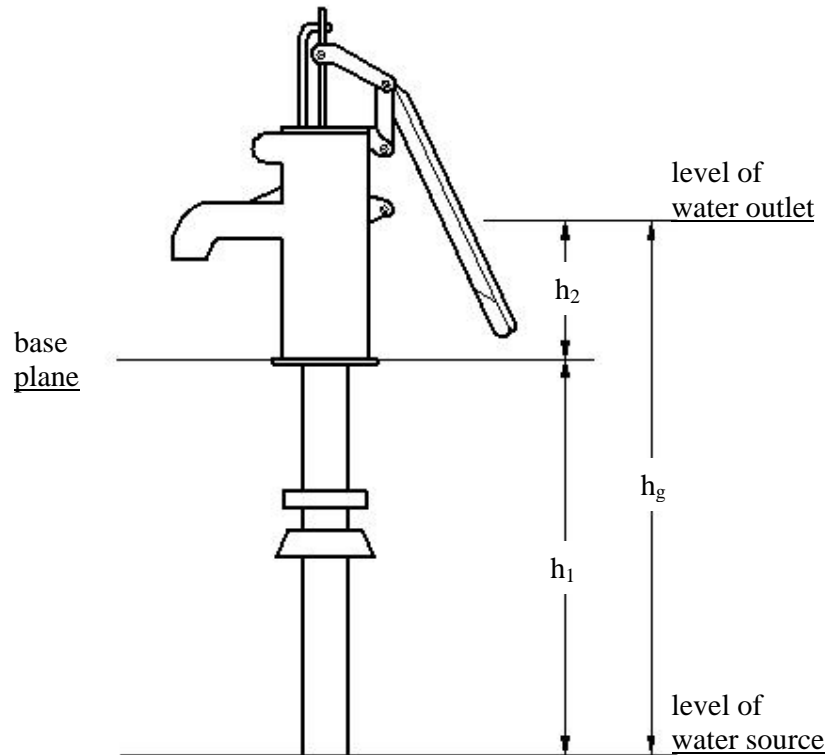

Figure 1. Pump head measurement.

4 General Conditions for Test and Inspection

4.1 Role of manufacturer/dealer

The manufacturer shall submit the operator's manual of hand pump and shall abide by the terms and conditions set forth by an official testing agency.

4.2 Role of the operator

An officially designated operator shall be skilled and shall be able to demonstrate, operate, adjust and make repairs related to the operation of the equipment.

4.3 Test site conditions

The pump shall be tested in a laboratory using a test rig. In the case of pump permanently installed, it shall be tested at the site where it is installed.

4.4 Test instruments/equipment

The suggested list of minimum test materials needed to carry out the hand pump test is shown in Annex A.

4.5 Ambient conditions

The ambient conditions such as atmospheric pressure, temperatures (dry bulb and wet bulb) and relative humidity shall be recorded at equal interval during the test.

4.6 Termination of test for hand pump

If during the test, the hand pump encounters major component breakdown or malfunction, the test engineer shall terminate the test.

5 Test and Inspection

5.1 Verification of the manufacturer's technical data and information

This inspection is carried out to verify the mechanism, dimensions and construction material of the hand pump in comparison with the list of manufacturer's technical data and information. All data shall be recorded in Annex B.

5.2 Performance test

5.2.1 This is carried out to obtain actual data on overall performance of the equipment.

5.2.2 Volumetric efficiency

5.2.2.1 This is carried out to determine the ratio of the actual volume of water discharge to that of the piston or plunger displacement in one stroke.

5.2.2.2 Actual Volume Discharge per stroke Determination

In a bucket, measure the actual water discharge by the pump in ten (10) full strokes.

5.2.2.3 Piston Displacement

The inside diameter of the cylinder and the actual length of stroke shall be measured.

Note: Piston displacement shall be computed using the formula given in Annex D.

5.2.2.4 Volumetric efficiency shall be calculated using the formula given in Annex D.

5.2.3 Energy expenditure of the operator

5.2.3.1 The heart rate of the operator shall be measured at the carotid artery or at the wrist before and after operations.

5.2.3.2 Estimated energy expenditure shall be obtained from the table presented below (Table 1).

Table 1. Estimated energy expenditure (Christensen scale for work load).

Physical work load	Heart rate Beat/min	Energy expenditure KJ/min
Very light	< 75	<20
light	75-100	10-20
Moderate heavy	100-125	20-30
Heavy	125-150	30-40
Very heavy	150-175	40-50
Extra heavy	>175	>50

5.2.3.3 The physical build of the operator such as stature, forward reach, hand length, etc. shall be measured.

5.2.3.4 The items to be measured and investigated shall be recorded in the Annex C.

5.2.4 Pump performance

5.2.4.1 Suction head or suction lift (h_1)

Suction head shall be measured from the water surface to the level of water in the discharge, as shown in Figure 1.

5.2.4.2 Temperature of the liquid

Temperature of the liquid shall be measured from the water discharge by the pump using a thermometer. All readings shall be recorded in Annex C.

5.2.4.3 The number of full strokes of operator in one minute of operation shall be recorded in Annex C.

5.2.4.4 The time spent and the number of strokes from no discharge state to maximum flow rate shall be recorded.

5.2.4.5 Total discharge head, total static head and water power shall be computed using the formula in Annex D.

5.2.4.6 Discharge of lift type hand pump

5.2.4.7 The discharge of the hand pump shall be obtained.

5.2.4.8 Pressure reading and computation of total dynamic head (TDH) for force type

5.2.4.8.1 Pressure gauges shall be attached to the suction side (vacuum gauge) and to the discharge side (discharge pressure gauge) of the force pump (Fig. 2).

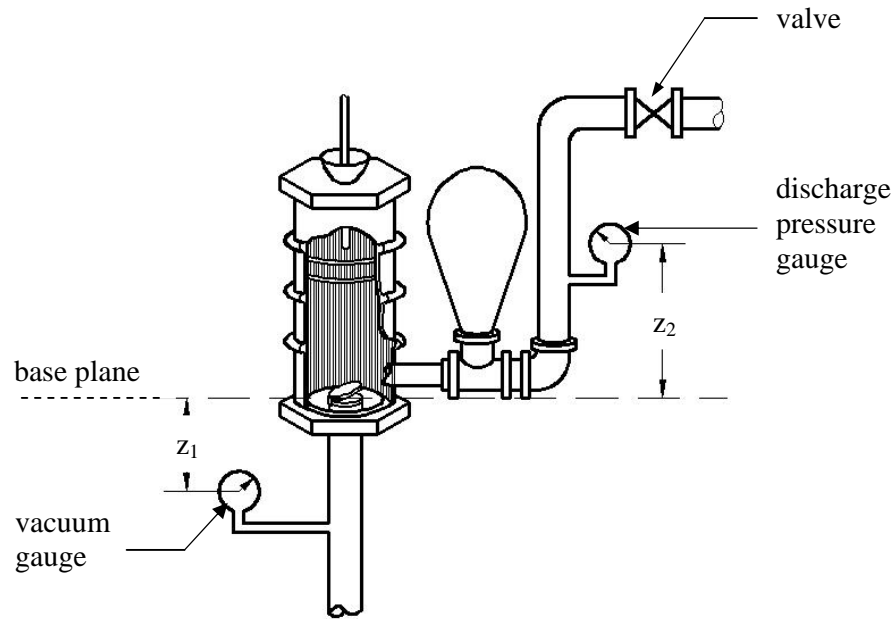

Figure 2. Pressure reading for force type hand pump.

5.2.4.8.2 With the valve closed, the force pump shall be operated. The pressure readings shall be read and shall be recorded. This shall yield the maximum pressure that the pump can hold. The number of full strokes to sustain that pressure shall also be noted.

5.2.4.8.3 The valve shall be adjusted to obtain new set of readings. The pressure readings for the respective discharge values shall be recorded. At least five (5) sets of pressure readings and amount of discharge shall be obtained and shall be plotted in the graph with the latter as the independent variable.

5.2.4.8.4 The heads at the discharge and at the suction sides shall be computed using the formula in Annex D.

5.2.4.8.5 The total dynamic head shall be computed using the formula in Annex D.

5.2.5 All data shall be recorded in Annex C.

5.3 Test trial

There shall be at least three (3) trials to conduct the test.

6 Test Report

The test report shall include the following information in the order given:

- 6.1 Title
- 6.2 Summary
- 6.3 Purpose and Scope of Test
- 6.4 Methods of Test
- 6.5 Description of the Machine

Table 1 – Machine Specifications

- 6.6 Results and Discussions
- 6.7 Observations (include pictures)

Table 2 –Performance test data

- 6.8 Name(s), signature(s) and designation(s) of test engineer(s)

Annex A

Suggested Minimum List of Test Equipment

Items	Quantity
A.1. timer accuracy: 0.10 s	1
A. 2 measuring tape	1
A.3 discharge measurement	
bucket capacity: 22.7 L (5 gal)	1
A.4 pressure gauge capacity: 10 kPa	1
A.5 ambient conditions	
thermometer	1
barometer	1
A.6 calculations	
scientific calculator	1
A.7 temperature of liquid	
thermometer	1

Annex B
(informative)

Specifications of Hand Pump

Name of Applicant/ Distributor: _____

Address: _____

Tel No: _____

GENERAL INFORMATION

Name of Manufacturer: _____

Make: _____

Classification: _____

Serial No: _____ Brand/Model: _____

Production date of hand pump to be tested: _____

Testing Agency: _____ Test Engineer: _____

Date of Test: _____ Location of Test: _____

Items to be inspected

ITEMS	Manufacturer's Specification	Verification by the Testing agency
B.1 overall dimensions		
B.1.1 overall length, mm		
B.1.2 overall width, mm		
B.2 handle		
B.2.1 length, mm		
B.2.2 thickness, mm		
B.2.3 material		
B.2.4 weight (without counterweight), kg		
B.3 counterweight (if present)		
B.3.1 weight, kg		
B.3.2 material		
B.3.3 means of attachment		
B.4 pump head assembly		
B.4.1 width, mm		
B.4.2 length, mm		
B.4.3 height, mm		
B.4.3 material		
B.5 discharge outlet		
B.5.1 width/diameter, mm		
B.5.2 length, mm		
B.5.3 thickness, mm		
B.5.4 material		
B.6 plunger/piston		
B.6.1 stroke, mm		
B.6.2 diameter, mm		

ITEMS	Manufacturer's Specification	Verification by the Testing agency
B.6.3 thickness, mm		
B.6.4 material		
B.6.5 weight. kg		
B.7 cylinder		
B.7.1 bore, mm		
B.7.2 thickness, mm		
B.7.3 material		
B.8 gasket		
B.8.1 thickness, mm		
B.8.2 material		
B.9 check valve		
B.9.1 diameter, mm		
B.9.2 material		
B.9.3 type of filtering (if present)		
B.10 discharge valve		
B.10.1 diameter, mm		
B.10.2 material		
B.11 discharge, Lpm		

ANNEX C

Performance Test Data Sheet

Items to be measured and Inspected

C.1 Water conditions	Remarks
C.1.1 source of water	
C.1.2 location	

C.2 Ambient conditions	
C.2.1 temperature	
C.2.1.1 dry bulb, °C	
C.2.1.2 wet bulb, °C	
C.2.1.3 relative humidity, %	
C.2.1.4 atmospheric pressure, Pa	

C.3 Volumetric efficiency				
Items	Trials			Average
	1	2	3	
C.3.1 actual volume of water discharged in 10 full strokes, m ³				
C.3.2 piston displacement, m ³				
C.3.3 volumetric efficiency, %				

C.4 Energy expenditure				
Items	Trials			Average
	1	2	3	
C.4.1 initial heart rate of the operator, beat/min				
C.4.2 final heart rate of the operator, beat/min				
C.4.3 estimated energy expenditure, kJ/min				
C.4.4 operator's build:				
C.4.4.1 forward reach, m				
C.4.4.2 hand length, m				
C.4.4.3 others:				

C.5 Pump performance				
Items	Trials			Average
	1	2	3	

C.7 Plot of discharge pressure versus discharge

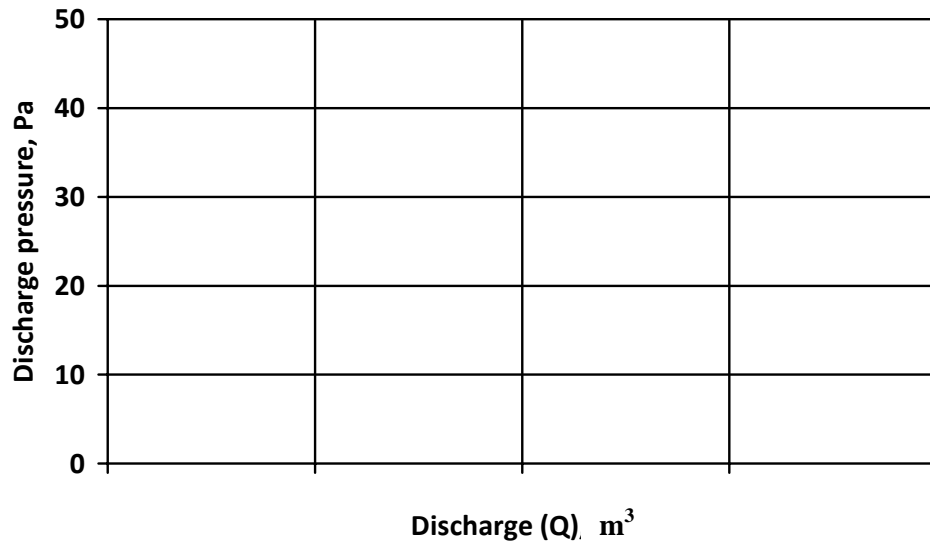

ANNEX D

Formula Used During Calculation and Testing

D.1 Piston displacement

$$P_d = \frac{\pi D^2 h}{4}$$

where:

P_d	piston displacement, m ³
D	piston diameter, m ²
h	maximum length of stroke, m

D.2 Total static head

$$H_g = h_1 + h_2$$

where:

H_g	total static head, m
h_1	total suction head, m
h_2	total discharge head, m

D.3 Total discharge head

$$h_2 = h_d + h_f$$

where:

h_2	total discharge head, m
h_d	discharge head, m
h_f	friction head, m

D.4 Total suction head

$$h_1 = h_s + h_f$$

where:

h_1	total suction head, m
h_s	suction head, m
h_f	friction head, m

D.5 Friction head

$$h_f = \frac{fLV^2}{D2g}$$

where:

h_f	friction head, m
f	coefficient of friction loss
L	pipe length, m
D	pipe diameter, m
V	velocity of the water, m/s
g	acceleration due to gravity, m/s ²

D.6 Water power

$$WP = \frac{TH \times Q}{102}$$

where:

WP	water power, kW
H_g	total static head, m
Q	discharge rate, L/s

D.7 Volumetric efficiency

$$n = \frac{Q_a}{P_d} \times 100$$

where:

n	volumetric efficiency of pump, %
Q_a	actual discharge, m ³
P_d	piston displacement, m ³

D.8 Total dynamic head

$$TDH = h_d - h_s$$

where:

TDH	total dynamic head, m
h_d	head at discharge side, m
h_s	head at suction side, m

D.9 Head at the discharge side

$$h_d = P_2 + \frac{v^2}{2g} + z_2$$

where:

h_d	head at discharge side, m
P_2	pressure at discharge side
v	column velocity at the discharge side, m/s
g	acceleration due to gravity, m/s ²
z_2	gauge correction factor, m

D.10 Head at the suction side

$$h_s = P_1 + \frac{v^2}{2g} + z_1$$

where:

h_s	head at discharge side, m
P_1	pressure at discharge side
v	column velocity at the discharge side, m/s
g	acceleration due to gravity, m/s ²
z_1	gauge correction factor, m

Philippine Agricultural Engineering Standards

AMTEC-UPLB – PCARRD Project: “Development of Standards for Agricultural Production and Postharvest Machinery”

Technical Committee 1. Production Machinery

Chairman: Engr. Joel R. Panagsagan
Agricultural Machinery Manufacturers and Distributors Association
(AMMDA), Inc.

Members: Dr. Caesar Joventino M. Tado
Philippine Rice Research Institute (PhilRice)

Engr. Francia M. Macalintal
National Agricultural and Fishery Council (NAFC)
Department of Agriculture

Engr. Julieto T. Uriarte
Metal Industry Research and Development Center (MIRDC)
Department of Science and Technology

Engr. Angelito V. Angeles
Philippine Society of Agricultural Engineers (PSAE)

Technical Committee 2. Postharvest Machinery

Chairman: Engr. George Q. Canapi
Agricultural Machinery Manufacturers and Distributors Association
(AMMDA), Inc.

Members: Engr. Dionisio C. Coronel, Sr.
National Food Authority (NFA)
Department of Agriculture

Engr. Reynaldo P. Gregorio
Bureau of Postharvest Research and Extension (BPRE)
Department of Agriculture

Engr. Jose B. Ferrer
Metal Industry Research and Development Center (MIRDC)
Department of Science and Technology

Dr. Elmer D. Castillo
Philippine Society of Agricultural Engineers (PSAE)

your partner in product quality and safety



BUREAU OF PRODUCT STANDARDS

3F Trade and Industry Building
361 Sen. Gil J. Puyat Avenue, Makati City 1200, Metro Manila, Philippines
T/ (632) 751.3125 / 751.3123 / 751.4735
F/ (632) 751.4706 / 751.4731
E-mail : bps@dti.gov.ph
www.dti.gov.ph