

PHILIPPINE NATIONAL STANDARD

**PNS/BAFS/PAES 223:2017
ICS 65.060.35**

Design of a Pressurized Irrigation System – Part A: Sprinkler Irrigation



BUREAU OF AGRICULTURE AND FISHERIES STANDARDS

BPI Compound Visayas Avenue, Diliman, Quezon City 1101 Philippines
Phone (632) 920-6131; (632) 455-2856; (632) 467-9039; Telefax (632) 455-2858
E-mail: bafpsda@yahoo.com.ph
Website: www.bafps.da.gov.ph

Foreword

The formulation of this national standard was initiated by the Agricultural Machinery Testing and Evaluation Center (AMTEC) under the project entitled “Enhancement of Nutrient and Water Use Efficiency Through Standardization of Engineering Support Systems for Precision Farming” funded by the Philippine Council for Agriculture, Aquaculture and Forestry and Natural Resources Research and Development - Department of Science and Technology (PCAARRD - DOST).

As provided by the Republic Act 10601 also known as the Agricultural and Fisheries Mechanization Law (AFMech Law of 2013), the Bureau of Agriculture and Fisheries Standards (BAFS) is mandated to develop standard specifications and test procedures for agricultural and fisheries machinery and equipment. Consistent with its standards development process, BAFS has endorsed this standard for the approval of the DA Secretary through the Bureau of Agricultural and Fisheries Engineering (BAFE) and to the Bureau of Philippine Standards (BPS) for appropriate numbering and inclusion to the Philippine National Standard (PNS) repository.

This standard has been technically prepared in accordance with BPS Directives Part 3:2003 – Rules for the Structure and Drafting of International Standards.

The word “shall” is used to indicate mandatory requirements to conform to the standard.

The word “should” is used to indicate that among several possibilities one is recommended as particularly suitable without mentioning or excluding others.

CONTENTS		Page
1	Scope	1
2	References	1
3	Definitions	1
4	Components of a Sprinkler Irrigation System	5
5	General Design Criteria	6
6	Limitations	7
7	Types of Sprinkler Systems	7
8	Data Requirements	10
9	Preliminary Design Procedure	10
10	Final Design Procedure	12
11	Bibliography	21
 ANNEXES		
A	Types of Sprinklers	22
B	Recommended Materials for Mainlines, Submainlines and Laterals	25
C	Sample Design Computation	29

Design of a Pressurized Irrigation System – Part A: Sprinkler Irrigation

1 Scope

This standard provides minimum requirements, criteria and procedure for the design of a periodic-move and a continuous-move sprinkler irrigation system.

2 References

The following normative documents contain provisions, which, through reference in this text, constitute provisions of this National Standard:

PNS/BAFS/PAES 217:2017 Determination of Irrigation Water Requirements

3 Definitions

For the purpose of this standard, the following terms shall apply:

3.1**average pressure**

average sprinkler pressure of a lateral

3.2**design pressure**

pressure required to overcome the elevation difference between the water source and the sprinkler nozzle, to counteract friction losses and to provide adequate pressure at the nozzle for good water distribution

3.3**distribution uniformity**

numerical value on the uniformity of application for agricultural irrigation systems

3.4**irrigation period**

time required to cover an area with one application of water

3.5**sprinkler irrigation**

method of applying irrigation water similar to natural rainfall where water is distributed through a system of pipes by pumping and then sprayed into the air through sprinklers so that it breaks up into small water drops which fall to the ground

3.6

sprinkler spacing

distance between two sprinkler heads along the lateral (see Figure 1)

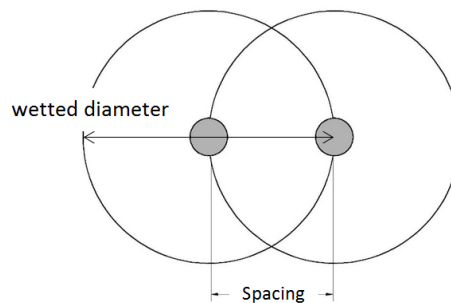

Figure 1. Sprinkler spacing and wetted diameter

SOURCE: FAO - Irrigation Manual Volume III – Module 8, 2001

3.7

wetted diameter

diameter of the circular area wetted by the sprinkler when operating at a given pressure and no wind (See Figure 1)

4 Components of Sprinkler Irrigation System

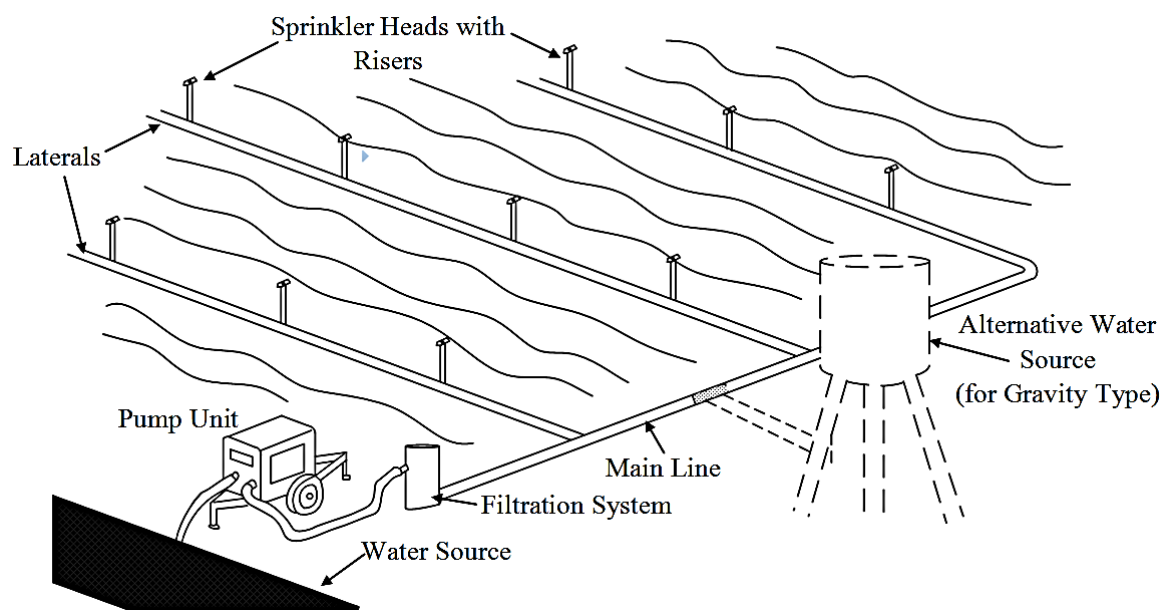

Figure 2. A typical sprinkler irrigation system and its components

4.1 Pump Unit – delivers water from the source to the pipe system at an adequate capacity

4.2 Filtration System – consists of screen openings considerably lower than the nozzle diameter to prevent nozzles from clogging

4.3 Sprinklers – device of various nozzle sizes which sprays water over the ground or crop. Different types of sprinklers are shown in Annex A.

4.4 Mainline and Submainlines – pipes which convey water from the pump to the laterals

4.5 Laterals – deliver water from the mainlines or submainlines to the sprinklers

Materials recommended for use in mainlines, submainlines and laterals are shown in Annex B.

5 General Design Criteria

5.1 Type of Crop – Sprinkler irrigation shall be used in crops and trees where water can be sprayed over or under the crop canopy. Large sprinklers shall not be used in delicate crops to avoid damage.

5.2 Slope – Sprinkler irrigation can be used in uniform or undulating slopes. Lateral pipes shall always be laid out along the land contour whenever possible in order to minimize the pressure changes at the sprinklers and provide uniform irrigation.

5.3 Soil Type – Sprinkler irrigation may be used in almost any type of soil except those which easily form a crust. It is best used in sandy soils with high infiltration rates. The application rate shall always be less than the basic infiltration rate of the soil. Infiltration rate may be determined using the method described in Annex C of PAES 607:2016.

5.4 Irrigation Water – The irrigation water shall be free of suspended sediments to avoid nozzle blockage.

5.5 Layout – The following layout configurations shall be considered:

5.5.1 Mainlines shall be laid up and downhill.

5.5.2 Laterals shall be laid across slope or nearly on the counter.

5.5.3 For multiple lateral operation, lateral pipe sizes shall be limited to not more than two diameters.

5.5.4 Layout shall facilitate and minimize lateral movement during the season.

5.5.5 Differences in the number of sprinklers operating for the various setups shall be held to a minimum

6.5.6 Layout shall be modified to apply different rates and amounts of water where soils are greatly different in the design area.

6 Limitations

6.1 Sprinkler irrigation requires high initial and operating costs compared to surface irrigation systems.

6.2 Intermittent delivery of large flows and other forms of rate fluctuations are not economical and thus require reservoirs.

6.3 Salinity and high concentrations of bicarbonates in irrigation water affect the crops when used in overhead sprinklers.

6.4 Water of different quality causes corrosion to pipes commonly used in sprinkler irrigation.

6.5 Sprinkler irrigation is not suitable for soils with an intake rate of less than 3 mm/hr.

6.6 Windy and excessively dry conditions result to low irrigation efficiencies.

6.7 Non-rectangular field shapes are inconvenient for design especially for mechanized systems.

7 Types of Sprinkler Systems

7.1 Set System – operate with sprinklers set in a fixed position

7.1.1 Periodic-Move System – sprinklers that must be moved manually through a series of positions during the course of irrigation

7.1.1.1 Hand-Move System – composed of portable or buried pipe with valve outlets at intervals for attaching the portable laterals.

- Portable
- Semi-portable
- Drag-hose type

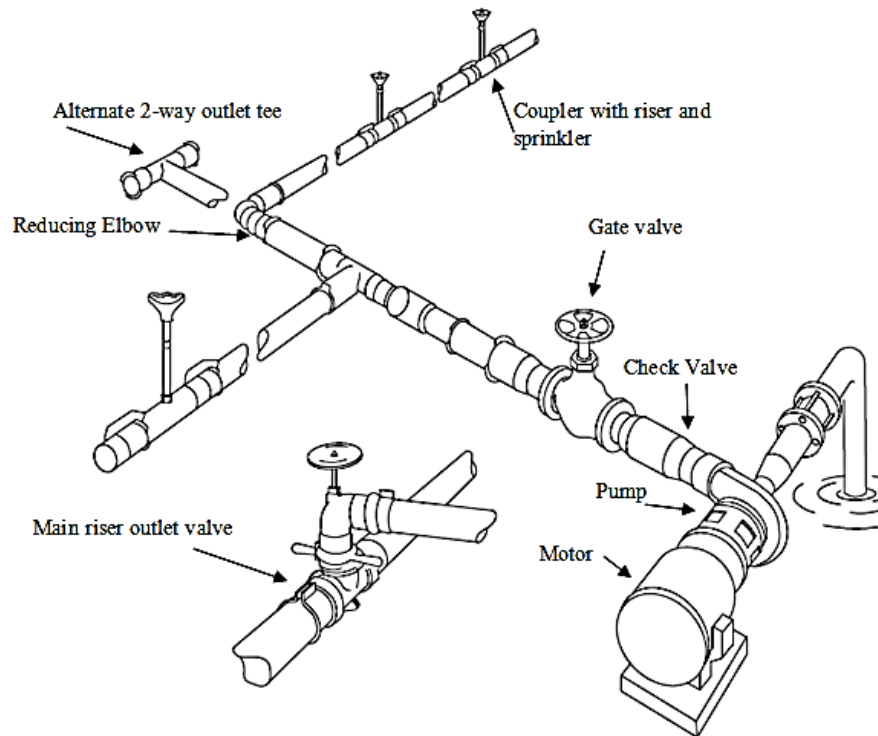

Figure 3. Portable Sprinkler System

SOURCE: Schwab, Soil and Water Conservation Engineering, 4th Edition, 1993

7.1.1.2 Mechanical-Move System

- Side-roll lateral system – the lateral pipes are rigidly coupled and each joint of pipe is supported by a large wheel where the lateral line forms the axle for the wheels. This is mechanically moved by an engine mounted at the center of the line.
- End-tow lateral system – consists of rigidly coupled lateral pipe connected to a buried mainline positioned in the center of the field. Laterals are towed lengthwise over the mainline from one side to the other in an “s” form
- Gun and boom sprinkler system –nozzles are attached to long discharge tubes and rotated by means of a rocker arm drive

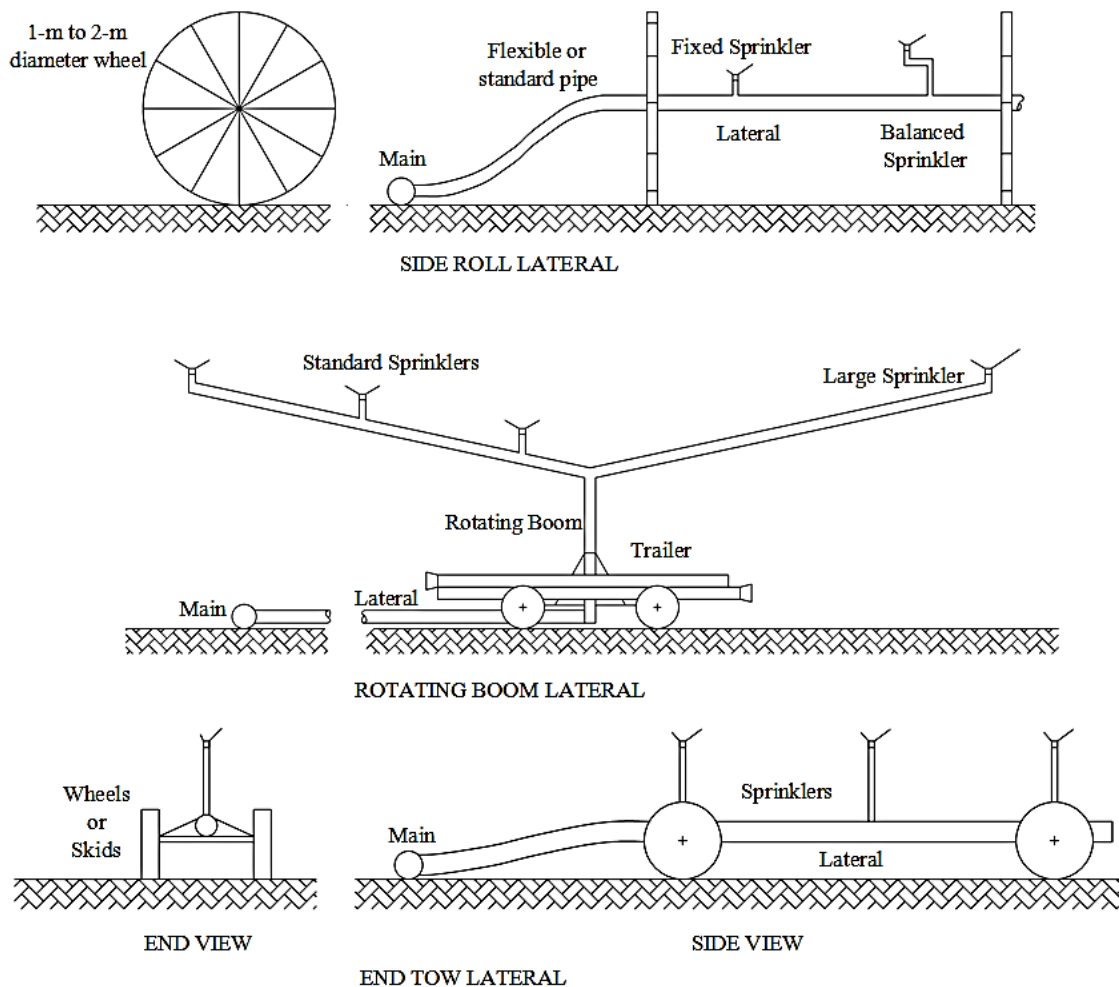

Figure 4. Mechanical-move Sprinkler Systems

SOURCE: Schwab, Soil and Water Conservation Engineering, 4th Edition, 1993

7.1.2 Fixed System – sprinkler systems not requiring to be moved during the course of irrigation

- Solid-set
- Permanent Buried
- Sequencing-Valve Laterals

7.2 Continuous Move System – sprinklers operate while moving in either a circular or straight path.

- Center-Pivot – sprinkles water from a continuously moving lateral pipeline. The self-propelled lateral is fixed at one end and rotates to irrigate a large circular area. The fixed end of the lateral, called the pivot point is connected to the water supply.
- Linear-Move – combine the structure and guidance system of a center-pivot lateral with a traveling water-feed system similar to a travelling sprinkler
- Travelling – high capacity sprinkler fed with water through a flexible hose which is mounted on a self-powered chassis and travels along a straight line while watering

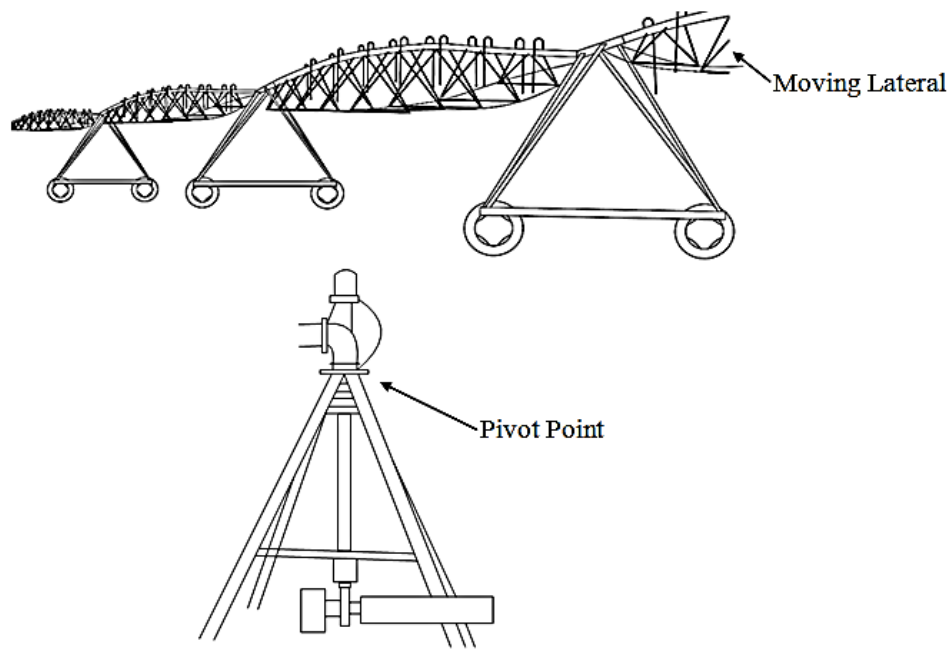

Figure 5. Center pivot sprinkler system

SOURCE: FAO Technical Handbook on Pressurized Irrigation Techniques, 2000

8 Data Requirements

8.1 Topographic map – the topographic map shall include the following details:

- the proposed irrigated area, with contour lines
- farm and field boundaries and water source or sources
- power points, such as electricity lines, in relation to water source and area to be irrigated
- roads and other relevant general features such as obstacles

8.2 Water resources data

- quantity and quality of water resources over time
- water rights
- cost of water if applicable

8.3 Climate of the area and its influence on the water requirements of the selected crop

8.4 Soil characteristics and their compatibility with the crops

9 Preliminary Design Procedure

The following parameters shall be computed in designing a periodic-move and continuous-move sprinkler systems:

9.1 Net Depth of Water Application

$$d_{net} = (FC - PWP) \times d_{rz} \times MAD$$

where:

d_{net}	is the net depth of water application (mm)
FC-PWP	is the available moisture (mm/m)
d_{rz}	is the depth of root zone (m)
MAD	is the allowable moisture depletion (%)

9.2 Irrigation Frequency at Peak Demand

$$I_f = \frac{d_{net}}{peak\ ET_a}$$

where:

I_f	is the irrigation frequency (day)
d_{net}	is the net depth of water application (mm)
peak ET_a	is the actual evapotranspiration (see PNS/BAFS/PAES 217:2017-Determination of Irrigation Water Requirements) at peak period (mm/day)

9.3 Gross Depth of Water Application

$$d_{gross} = \frac{d_{net}}{E_a}$$

where:

d_{gross}	is the gross depth of water application (mm)
E_a	is the application efficiency

9.4 Preliminary System Capacity

$$Q_{prelim} = \frac{10 \times A \times d_{gross}}{I_f \times N_{shift} \times T}$$

where:

Q_{prelim}	is the preliminary system capacity (m ³ /h)
A	is the design area (ha)
d_{gross}	is the gross depth of water application (mm)
I_f	is the irrigation frequency (days)
N_{shift}	is the number of shifts per day
T	is the irrigation time per shift (h)

10 Final Design Procedure

10.1 Periodic-Move System

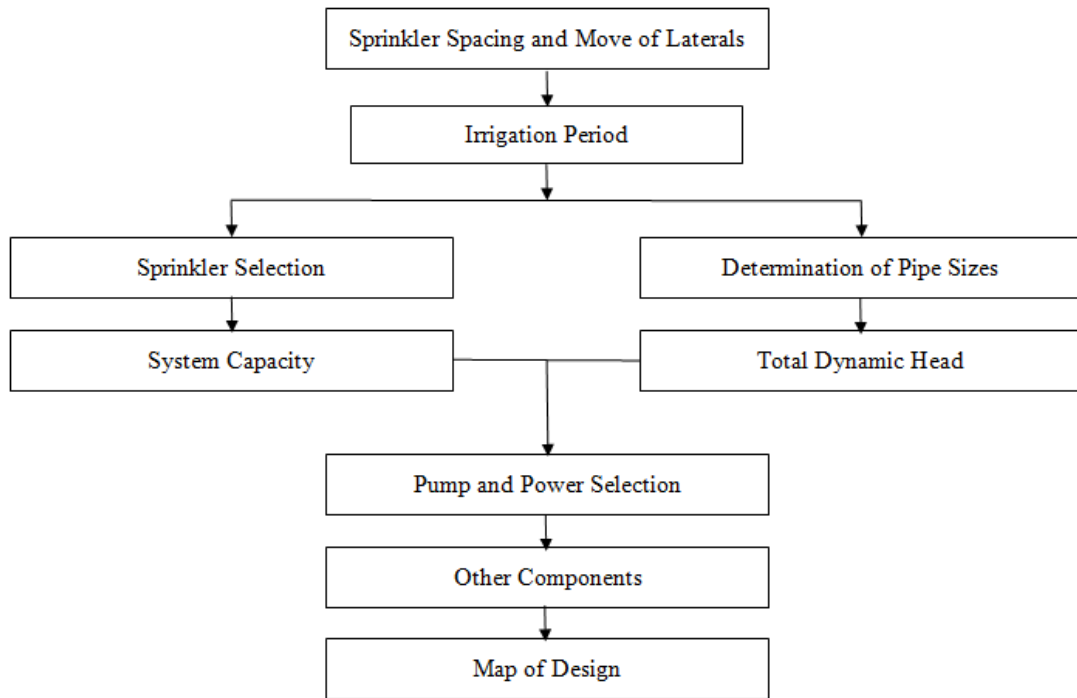

Figure 5. Final design procedure of a periodic-move sprinkler system

10.1.1 Sprinkler Spacing and Move of Laterals – Sprinkler spacing and lateral movement shall be decided based on the extent of field area, source of water and type of sprinkler irrigation system. If wind is a major factor in the area, Tables 1 and 2 may be used. Tables 1 and 2 show the suggested spacing of sprinklers and laterals based on the wind velocity and spacing pattern. Table 3 shows a sample suggested sprinkler spacing from a manufacturer’s data, based on the sprinkler size. Samples of sprinkler spacing patterns are shown in Figure 6.

Table 1. Maximum sprinkler spacing as related to wind velocity, rectangular pattern

Average Wind Speed (km/hr)	Spacing as Percent of Wetted Diameter (D)
Up to 10	40% between sprinklers, 65% between laterals
10-15	40% between sprinklers, 60% between laterals
above 15	30% between sprinklers, 50% between laterals

SOURCE: FAO - Irrigation Manual Volume III – Module 8, 2001

Table 2. Maximum sprinkler spacing as related to wind velocity, square pattern

Average Wind Speed (km/hr)	Spacing as Percent of Wetted Diameter (D)
Up to 5	55%
6-11	50%
13-19	45%

SOURCE: FAO - Irrigation Manual Volume III – Module 8, 2001

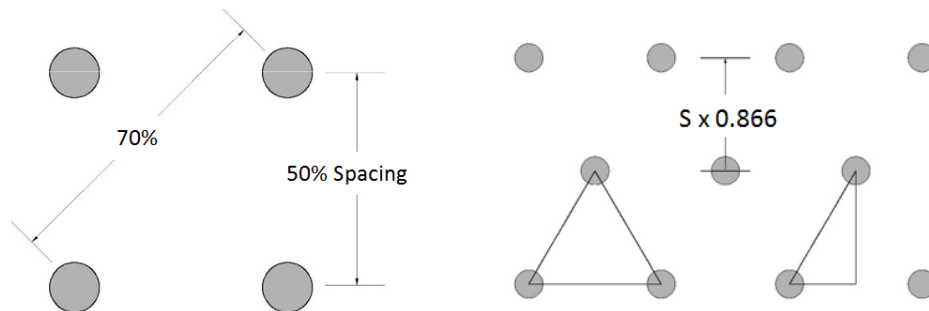

Figure 6. Square and triangular spacing patterns for sprinkler irrigation

10.1.2 Irrigation Period – This shall be set based on the sprinkler spacing and application rate.

10.1.3 Sprinkler Selection – Sprinklers shall be selected such that the average application rate is less than the infiltration rate of the soil. Data are usually available from the manufacturer of the sprinkler as shown in Table 3 and Table 4 or the theoretical nozzle discharge of the nozzle can be computed as follows:

$$q = S_l S_m r$$

$$q = 0.00111 C d_n^2 P^{1/2}$$

where:

- q is the discharge of each sprinkler (m³/h)
- S_l is the sprinkler spacing along the lateral (m)
- S_m is the sprinkler spacing along the main (m)
- r is the application rate (mm/h)
- C is the coefficient of discharge
- d_n is the diameter of the nozzle orifice (mm)
- P is the pressure at the nozzle (kPa)

Table 3. Sprinkler Specifications and Suggested Spacing

Sprinkler Specifications				Sprinkler application rate (mm/hr)					
Nozzle Size (mm)	Pressure (kPa)	q (m ³ /h)	Wetted Diameter (m)	Sprinkler Spacing (m x m)					
				9x12	9x15	12x12	12x15	15x15	18x18
3.0	250	0.57	25.00	5.28	4.22	3.96			
3.0	300	0.63	25.60	5.83	4.67	4.38			
3.0	350	0.68	26.20	6.30	5.04	4.72			
3.5	250	0.75	26.85	6.94	5.56	5.21	4.17		
3.5	300	0.82	27.60	7.59	6.07	5.69	4.56		
3.5	350	0.89	28.35	8.24	6.59	6.18	4.94		
4.0	300	1.08	26.60		8.00	7.50	6.00	4.60	
4.0	350	1.16	30.50		8.59	8.06	6.44	5.16	
4.5	300	1.32	30.95			9.17	7.33	5.87	
4.5	350	1.42	32.00			9.86	7.89	6.31	
4.5	400	1.52	33.05			10.56	8.44	7.56	
5.0	300	1.70	33.00				9.44	8.18	5.25
5.0	350	1.84	34.30				10.22	8.18	5.68
5.0	400	1.96	35.60				10.89	8.71	6.05

SOURCE: FAO - Irrigation Manual Volume III – Module 8, 2001

Table 4. Sample Sprinkler Characteristics for a Head with Two Nozzles

Nozzle Pressure (kPa)	Nozzle Diameters (mm)					
	3.97 x 3.18		4.76 x 3.97		6.35 x 3.97	
	Wetted Diameter (m)	Discharge (L/s)	Wetted Diameter (m)	Discharge (L/s)	Wetted Diameter (m)	Discharge (L/s)
207	25	0.37	26	0.52	28	0.76
276	27	0.43	28	0.61	31	0.90
345	28	0.47	30	0.68	34	1.00
414	30	0.52	31	0.74	36	1.10

SOURCE: Fangmeier, D.D, et al. 2006. Soil and Water Conservation Engineering, Fifth Edition

10.1.4 System Capacity

$$Q = N_c \times N_s \times q$$

where:

- Q is the system capacity (m³/h)
- N_c is the number of laterals operating per shift
- N_s is the number of sprinklers per lateral
- q is the discharge of each sprinkler (m³/h)

10.1.5 Determination of Pipe Sizes – The following shall be considered in selecting pipe sizes for mains and laterals:

10.1.5.1 The total pressure variation in the laterals, if practicable shall not be more than ±10% of the design pressure.

10.1.5.2 If the lateral runs up or downhill, allowance for the difference in elevation shall be made in determining the variation in the head.

10.1.5.3 The diameter of the main shall be adequate to supply the laterals in each of their positions.

10.1.5.4 The position of the lateral that gives the highest friction loss in the main shall be considered.

10.1.5.5 The allowable friction loss in the laterals is 20% of the average pressure.

10.1.5.6 The velocity in the main line shall be less than or equal to 2 m/s.

10.1.6 Friction Loss in Main Lines - can be determined using Hazen-Williams Equation, Darcy Weisbach or other friction loss formula. The formula given below is based on Hazen Williams

$$H_f = \frac{1.21 \times 10^{10} L \left(\frac{Q}{C}\right)^{1.852}}{D^{4.87}}$$

where:

- H_f is the total friction loss in pipe with the same flow throughout (m)
- L is the length of pipe (m)
- Q is the total discharge (L/s)
- C is the pipe roughness coefficient
145 to 150 for plastic pipe
120 for aluminum pipe with couplers and new or coated steel pipe
- D is the inside diameter of pipe (mm)

10.1.7 Friction Loss in Laterals

$$h_f = H_f \times F$$

where:

- h_f is the friction loss in the lateral (m)
- H_f is the total friction loss in pipe with the same flow throughout (m)
- F is the correction factor depending on the number of outlets in the lateral (Table 5)

Table 5. F factors for various number of outlets

Number of outlets	F	Number of outlets	F
1	1.000	14	0.370
2	0.625	15	0.367
3	0.518	16	0.365
4	0.469	17	0.363
5	0.440	18	0.361
6	0.421	19	0.360
7	0.408	20	0.369
8	0.398	21	0.357
9	0.391	22	0.355
10	0.385	23	0.353
11	0.380	24	0.351
12	0.376	25	0.350
13	0.373		

SOURCE: Keller, J. and R.D Bliesner. 1990. Sprinkle and Trickle Irrigation

10.1.8 Average Pressure Head

$$H_a = H_d + 0.26h_f + \frac{S_e L_L}{2}$$

where:

- H_a is the average sprinkler pressure of a lateral (m)
- H_d is the sprinkler pressure at the distal end of the lateral (m)
- h_f is the friction loss in the lateral (m)
- S_e is the uniform slope of the lateral from the inlet – positive slope is uphill
- L_L is the lateral length (m)

10.1.9 Sprinkler Pressure at the Inlet to the Lateral

$$H_o = H_a + 0.74h_f + \frac{S_e L_L}{2}$$

where:

- H_o is the sprinkler pressure at the inlet to the lateral (m)
- H_a is the average sprinkler pressure of a lateral (m)
- h_f is the friction loss in the lateral (m)
- S_e is the uniform slope of the lateral from the inlet – positive slope is uphill
- L_L is the lateral length (m)

10.1.10 Total Dynamic Head

$$TDH = H_n + H_m + H_j + H_s$$

$$H_n = H_o + H_{rh}$$

where:

- TDH is the total dynamic head against which the pump is working (m)
- H_n is the head required at the junction of the lateral and the main (m)
- H_m is the maximum friction loss in the main and the suction line (m)
- H_j is the elevation difference between the pump and the junction of the lateral and the main (m)
- H_s is the elevation difference between the pump and the water supply after drawdown (m)
- H_o is the sprinkler pressure at the inlet to the lateral (m)
- H_{rh} is the riser height (m)

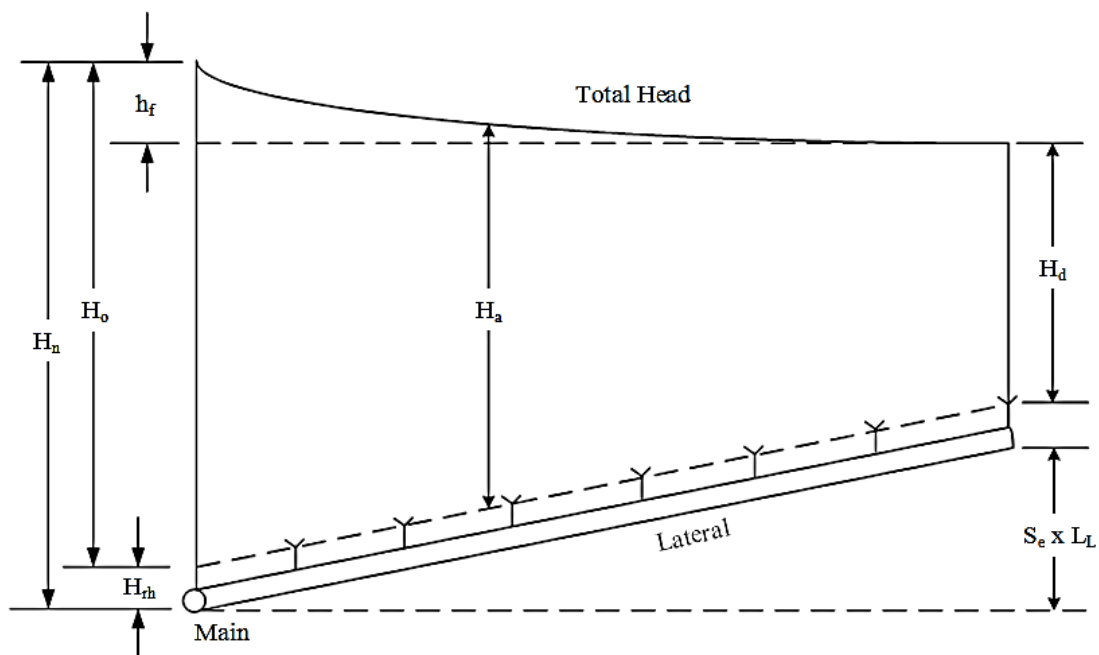

Figure 7. Head Losses in a Sprinkler Irrigation System

SOURCE: Fangmeier, D.D, et al. 2006. Soil and Water Conservation Engineering, Fifth Edition

10.1.11 System Capacity – the total sprinkler discharge

$$Q = q \times N$$

where:

- Q is the system capacity (m^3/h)
- q is the discharge of each sprinkler (m^3/h)
- N is the total number of sprinklers

10.1.12 Pump and Power Selection – the pump power requirement shall be computed as follows:

$$P = \frac{Q \times TDH}{360 \times E_p}$$

where:

- P is the power requirement (kW)
- Q is the system capacity (m³/h)
- TDH is the total dynamic head against which the pump is working (m)
- E_p is the pump efficiency from the pump performance chart

10.1.13 Other Components – The following components must be sized and selected based on the parameters computed above:

- Fittings and pipes
- Protective cage for sprinklers
- Shed for the power components
- Headworks

10.1.14 Map of Design – The map of design shall include the following:

- Map of the area
- System layout indicating the position of the mains and laterals
- Map of uphill and downhill flow
- Bill of quantities

10.2 Continuous-Move System

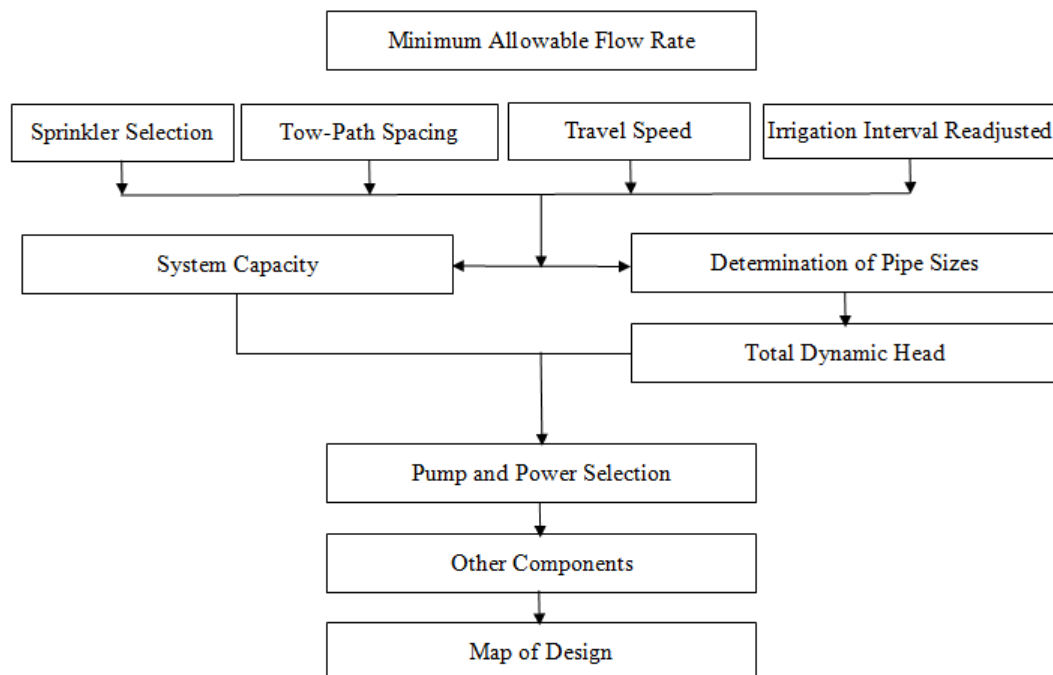

Figure 7. Final design procedure of a continuous-move sprinkler system

10.2.1 Maximum Allowable Flow Rate – The maximum allowable flow rate shall not exceed the soil’s infiltration rate. The sprinkler’s application rate can be computed using the formula

$$I = \frac{K \times Q_{sprinkler} \times 360}{\pi \times (0.9 \times R)^2 \times w}$$

where:

- I is the approximate infiltration rate or approximate sprinkler application rate (mm/hr)
- K is the conversion constant, 3600
- Q is the sprinkler discharge (l/s)
- R is the wetted radius of sprinkler (m)
- w is the portion of circle receiving water (degrees)

10.2.2 Sprinkler Selection – The type of sprinkler shall be based on jet trajectory and operating pressure.

10.2.2.1 Jet Trajectory

- Most travellers use gun sprinklers with trajectory angles ranging between 18 and 32 degrees.
- High angles give maximum coverage only under low wind conditions and this minimizes droplet impact.
- For winds exceeding 16 km/hour, gun sprinklers with trajectory angles between 20 and 21 degrees should be used.
- Where winds are below 16 km/hr, sprinklers with trajectory angles from 26 to 28 degrees are better.
- Low angles generally result in large droplets which are not good for some crops, especially leaf crops such as tobacco.

10.2.2.2 Operating Pressure - Data are usually available from the manufacturer of the sprinkler. A sample data is shown in Table 6.

Table 6. Sprinkler Specifications

Sprinkler Pressure m	Diameter of Tapered Nozzle (mm)									
	20.3		25.4		30.5		35.6		40.6	
	Sprinkler Discharge and Wetted Diameter									
	l/s	m	l/s	m	l/s	m	l/s	m	l/s	m
42.18	9.02	86.87	14.20	99.06	20.82	111.25	-	-	-	-
49.21	9.78	91.44	15.46	103.63	22.40	115.82	30.29	132.59	-	-
56.24	10.41	94.49	16.41	108.20	23.98	120.40	34.50	138.68	42.59	146.3
63.27	11.04	97.54	17.35	111.25	25.56	124.97	34.39	143.26	45.12	150.88
70.30	11.67	100.58	18.30	114.30	26.82	128.02	36.28	146.30	47.64	155.45
77.33	12.30	103.63	19.25	117.35	28.08	131.06	38.18	149.35	48.85	158.50
84.36	12.94	106.68	20.19	120.40	29.34	134.11	39.75	152.40	52.06	163.07

SOURCE: Keller and Bliesner, Sprinkle and Trickle Irrigation, 1990

10.2.3 Tow Path Spacing – This should be selected such that it would provide the best possible spacing between any two tow-paths. Table 7 gives an example of recommended tow-path spacings for gun sprinklers.

Table 7. Typical Recommended Tow-Path Spacings for Traveling Gun Sprinklers under Various Wind Conditions

Sprinkler Wetted Diameter M	Wind Speed (km/hr)						
	Over 16		8-16		3.2-8		0-3.2
	Spacing as a Percentage of Wetted Diameter						
	50	55	60	65	70	75	75
	Tow Path Spacing						
60.96	30.44	33.53	36.58	39.62	42.67	45.72	48.77
76.20	38.10	41.76	45.72	49.38	53.34	57.00	60.96
91.44	45.72	50.29	54.86	59.44	64.01	68.58	73.15
106.68	53.34	58.52	64.01	69.19	74.68	79.86	85.34
121.92	60.96	67.06	73.15	79.25	85.34	91.44	94.54
137.16	68.58	75.59	82.30	89.00	96.01	103.02	109.73
152.40	76.20	83.82	91.44	99.06	106.68	114.30	121.92
167.64	83.82	90.05	100.58	109.12	117.35	125.58	134.11
188.88	91.44	100.58	109.73	118.87	128.02	-	-

SOURCE: Keller and Bliesner, Sprinkle and Trickle Irrigation, 1990

10.2.4 Travel Speed – Compute the travel speed based on the formula below

$$v = \frac{k \times Q}{d_{gross} \times W}$$

where:

- | | |
|-------------|--|
| d_{gross} | is the gross depth of water application (mm) |
| k | is the conversion constant, 60 |
| Q | is the sprinkler discharge (l/s) |
| v | is the travel speed (m/min) |
| W | is the tow-path spacing (m) |

10.2.5 Readjusted Irrigation Interval – The irrigation interval shall be adjusted based on the designed operating capacity of the gun sprinkler to travel one tow-path length in about 23 hours for a single shift per day or 11 hours for 2 shifts per day. For 2 shifts, 1 hour is provided for between the shifts in order to allow for the change to the next tow-path.

10.2.6 Hose Length Determination – Calculate the standing positions and time per operation. It may be assumed that the hose should be as long as the distance from one end of the field to another, along the tow-path length.

10.2.7 Total Dynamic Head – The total dynamic head shall be computed as the sum of the following:

- Sprinkler operating pressure
- Friction loss in hose
- Head loss in traveller
- Head loss in automatic valve
- Riser height
- Friction loss in mainline
- Suction head

- 10% of the sum of the above heads for fittings
- Elevation difference

10.2.8 Pump and Power Selection – the pump power requirement shall be computed as follows:

$$P = \frac{Q \times TDH}{360 \times E_p}$$

where:

- P is the power requirement (kW)
- Q is the system capacity (m³/h)
- TDH is the total dynamic head against which the pump is working (m)
- E_p is the pump efficiency from the pump performance chart

10.2.9 Other Components – The following components must be sized and selected based on the parameters computed above:

- Fittings and pipes
- Protective cage for sprinklers
- Shed for the power components
- Headworks

10.2.11 Map of Design – The map of design shall include the following:

- Map of the area
- System layout indicating the position of the mains and laterals
- Map of uphill and downhill flow
- Bill of quantities

11 Bibliography

Food and Agriculture Organization of the United Nations. 2001. Irrigation Manual Volume III – Module 8: Sprinkler Irrigation Systems: Planning, Design, Operation and Maintenance

Food and Agriculture Organization of the United Nations. 2002. Irrigation Manual Volume III – Module 10: Irrigation Equipment for Pressurized Systems

Keller, J. and R.D Bliesner. 1990. Sprinkle and Trickle Irrigation.

National Irrigation Administration. 1991. Irrigation engineering manual for diversified cropping.

National Resources Conservation Service – United States Department of Agriculture. 2012. Part 623: Irrigation – National Engineering Handbook.

Phocaidis, A. 2000. FAO Technical Handbook on Pressurized Irrigation Techniques.

Schwab, G.O., et al. 1993. Soil and Water Conservation Engineering. Fourth Edition

**ANNEX A
(informative)**

Types of Sprinklers

A.1 Impact sprinkler

A.1.1 Usually made of brass, stainless steel, aluminium and heavy duty plastic

A.1.2 Parts: the body, which in most cases incorporates the impact bridge, the impact arm with its counter weight, the spoon and the vane, the arm spring, the bearing assembly, which includes a number of washers and the bearing sleeve, and the nozzle

A.1.3 Operation: water coming out of the nozzle is directed by the spoon at a 90-degree angle, forcing the arm away from the impact bridge. The arm spring, after absorbing this energy, returns the arm to its original position, which hits the bridge and causes the body to rotate

A.1.4 The most common nozzle is the straight bore-type which at times is combined with a wind vane to facilitate better throw under windy conditions

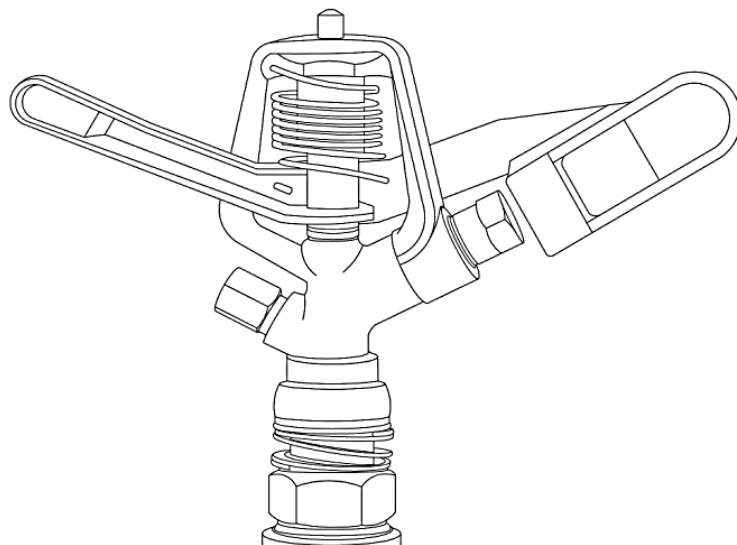

Figure A.1. Impact type sprinkler

A.2 Rotor and gear rotating sprinkler

A.2.1 Gear-driven sprinklers are mostly used for landscape irrigation while rotor-types of sprinklers are used for solid set, portable and semi-portable systems in agriculture as well as for landscape irrigation

A.2.2 Operation: water coming out of the nozzle is directed into an offset channel on the rotor plate, which creates a reactionary drive force that turns the sprinkler

A.2.3 Advantage: claims higher uniformity for the rotor sprinkler compared to impact sprinklers and the riser vibration caused by the impact sprinkler is avoided.

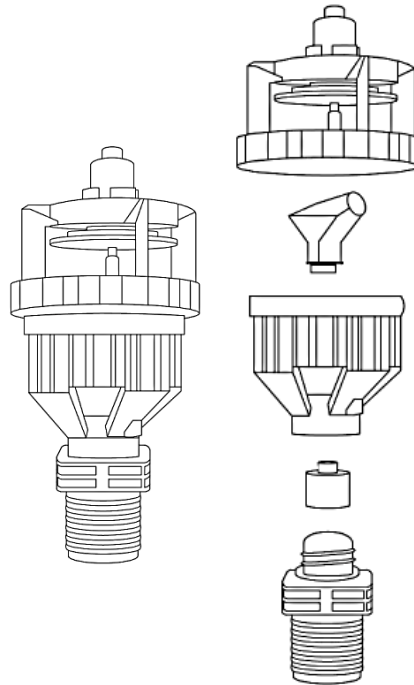

Figure A.2. Rotor and Gear Rotating Sprinkler

A.3 Stationary sprinkler

A.3.1 Manufactured from stable engineering plastic and silicon tubing, has a built-in flow controller, making it suitable for undulating terrain. It also has no moving parts and a unique flow pattern.

A.3.2 Operation: the water both from the sprinkler inlet and through the flow controller reaches the silicon tube, setting the tube in motion and water is spread on the field.

A.3.3 With various models with nominal discharge covering the range of 280-1400 l/hr.

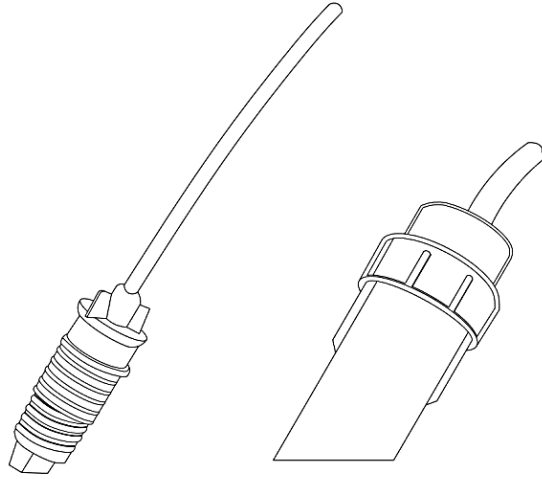

Figure A.3. Stationary Sprinklers

ANNEX B (informative)

Recommended Materials for Mainlines, Submainlines and Laterals

B.1 Steel threaded pipes

B.1.1 Have the ability to withstand stress, to resist high pressures and to maintain their strength for the duration of their service life, unlike plastic pipes which suffer a continuous creep strength with time and temperature fluctuations.

B.1.2 Mostly useful in small pieces needed for risers in the hydrants, connector tubes in the head control units and similar applications

B.1.3 Available in nominal diameters (DN), usually in inch-based series which correspond more or less to the actual bore diameter, and in several high pressure rates (classes) in accordance with various standards and recommendations (ISO R-65, BS 1387, DIN 2440/41/42, or to American Standards, etc.)

B.1.4 Supplied in random lengths of 6 m, they are for permanent assembling with screw-type (threaded) joints where pipe carries an internal threaded socket

B.1.5 Welded hot-dip galvanized steel pipes have an average life of 15-20 years on the surface 'in the atmosphere' and of 10-15 years in soil depending on soil physical properties

B.2 Quick coupling light steel pipes

B.2.1 Made of light rolled strip steel which has been hot-galvanized inside and outside

B.2.2 Each pipe is equipped with a hand-lever quick coupling welded on one end while the other end is arranged accordingly for water and pressureproof tight closure

B.2.3 Standard pipe length is 6 m and the working pressure (PN) ranges from 12.0 to 20.0 bars

B.2.4 Light in weight, easy to install and remove, and they are used as mains, submains, manifold feeder lines and laterals with sprinklers

B.2.5 Have a full range of pipe connector fittings of the same type of joints

B.2.6 Available in many sizes and in diameters (DN) of 70, 76 and 89 mm, which are convenient for farm-level pressure irrigation techniques

B.3 Quick coupling aluminum pipes

B.3.1 Mostly used, always above ground, as moveable lateral lines in sprinkler irrigation portable installations

B.3.2 Made of aluminium alloy by extrusion or by fusion welding

B.3.3 Light in weight (about half that of the light steel ones), relatively strong and durable. Manufactured in nominal diameters quoted in inches, corresponding to the outside pipe diameter, of 2, 3, 4, 5 and 6 in (51, 76, 102, 127 and 159 mm)

B.3.4 Minimum working pressure is 7.0 bars

B.3.5 In accordance with ISO 11678, the same sizes in the metric series are 50, 75, 100, 125 mm and so on with working pressures of 4.0, 10.0 and 16.0 bars

B.3.6 Supplied in standard lengths of 6, 9 and 12 m, complete with aluminium quick couplings are either detachable by means of clamps and rings, or permanently fixed on the tubes

B.3.7 Couplings seal automatically under high water pressure during operation and drain in pressures below 1.0 bar with the use of U-shaped rubber gaskets

B.3.8 Most widely used are the latch system (single or dual), with a 1 in threaded outlet for sprinkler risers, or hose extensions

B.3.9 Expected life of these pipes is 15 years under good management

B.3.10 Can be used not only as sprinkler lateral lines, but also as water conveyance and distribution lines

B.4 Rigid PVC pipes

B.4.1 Also called uPVC, these pipes are ideal for irrigation, (cold) water conveyance and distribution lines as mains and submains and in many cases can also serve as manifolds and laterals

B.4.2 Must always be laid permanently underground, protected from high or very low ambient temperatures and solar radiation

B.4.3 Maximum flow velocity should not exceed 1.5 m/s

B.4.4 Manufactured in standard lengths of 6 m

B.4.5 In accordance with the European standards and ISO 161, rigid PVC pipes are available in nominal diameters (DN), which is the approximate outside diameter, in 50, 63, 75, 90, 110, 125, 140, 160, 200 and 225 mm

B.4.6 Working pressures are 4.0, 6.0, 10.0 and 16.0 bars at 24°C. At higher temperatures, the working pressures decrease accordingly

B.4.7 Small diameter pipes up to 50 mm and inch-sized pipes have one end plain with a preformed socket at the other end for solvent cement welding

B.4.8 Larger diameter pipes have a tapered spigot at one end while the other end consists of a wall-thickened, preformed grooved socket with a rubber sealing ring for a push-fit integral mechanical joint

B.4.9 All the fittings and the valves of underground PVC pipelines should be thrust blocked to prevent them from moving whilst in operation due to the thrusting force of the water pressure

B.4.10 Estimated average life of buried uPVC pipes is 50 years

B.4.11 Minimum depth of cover should be 45 cm for pipes up to 50 mm, 60 cm for pipes up to 100 mm, and 75 cm for pipes over 100 mm

B.5 Polyethylene (PE) pipes

B.5.1 Extruded from polyethylene compounds containing certain stabilizers and 2.5 percent carbon black which protect the pipes against ageing and damage from sunlight and temperature fluctuations

B.5.2 LDPE (low-density resin) pipes are also known as soft polyethylene and PE 25, while HDPE pipes (highdensity resin) are more rigid and known as hard polyethylene or PE 50 (the numbers correspond to the pipe material's hydrostatic design stress)

B.5.3 Manufactured in accordance with various standards in inch-based and metric series (ISO 161-2, DIN 8072/8074, etc.)

B.5.4 All laterals with micro-emitters are LDPE pipes (hoses) of 12-32 mm.

B.5.5 HDPE pipes of larger diameters are used for main lines, submains and manifolds.

B.5.6 Supplied with plain ends in coils of 50-400 m, depending on the diameter.

B.5.7 Service life is 12-15 years when laid on the surface

B.5.8 Available in the following sizes: DN (external diameter) millimetres: 12, 16, 20, 25, 32, 40, 50, 63, 75, 90 and 110;

B.5.9 Available in the following working pressures:PN (working pressure) bars: 2.0, 4.0, 6.0, 10.0 and 16.0

B.5.10 Maximum flow velocity in the plastic pipes should not exceed 1.5 m/s

B.6 Layflat hose

B.6.1 An alternative to rigid PVC pipes for surface use as water conveyance lines, mains and manifolds, in drip and other low pressure micro-irrigation installations

B.6.2 Made of soft PVC reinforced with interwoven polyester yarn

B.6.3 Flexible, lightweight, and available in various sizes (millimetres or inches) from 1-6 in and for working pressures (PN) of 4.0-5.5 bars

B.6.4 Manufactured with plain ends and supplied in coils in standard lengths of 25, 50 and 100 m

B.6.5 Hoses are connected by inserting small pieces of PE piping into the ends of the hoses, or by metallic quick couplings attached to both pipe ends

B.6.6 Small diameter PE tubes are used to connect laterals to the layflat manifolds

ANNEX C
(informative)

Sample Computation for a Side-Roll System

Parameter	Value
Area to be irrigated, A	16 ha
Soil	silt loam to a depth of 0.9 m with coarse sand below
Crop	tomatoes
Peak daily water use, peak ET _a	5.0 mm/day
Available Moisture (FC-PWP)	120 mm/m
Allowable moisture depletion, MAD	40% or 0.4
Root-zone depth, d _{rz}	1.1 m (take 0.9 m since soil is only up to 0.9 m)
Soil infiltration rate	16 mm/h
Application Efficiency	70%
Average wind velocity	5 km/h

C.1 Preliminary Design

C.1.1 Net Depth of Water Application

$$d_{\text{net}} = (\text{FC} - \text{PWP}) \times d_{\text{rz}} \times \text{MAD} = 120 \times 0.9 \times 0.4 = 43.2 \text{ mm}$$

C.1.2 Irrigation Frequency

$$I_f = \frac{d_{\text{net}}}{\text{peak ET}_a} = \frac{43.2 \text{ mm}}{5.0 \text{ mm/day}} = 8.6 \text{ days or } 8 \text{ days}$$

Readjust d_{net} since I_f was readjusted.

$$d_{\text{net}} = \text{peak ET}_a \times I_f = 5.0 \frac{\text{mm}}{\text{day}} \times 8 \text{ days} = 40.0 \text{ mm}$$

C.1.3 Gross Depth of Water Application

$$d_{\text{gross}} = \frac{d_{\text{net}}}{E_a} = \frac{40.0}{0.70} = 57.1 \text{ mm}$$

C.1.4 Preliminary System Capacity

$$Q_{\text{prelim}} = \frac{10 \times A \times d_{\text{gross}}}{I_f \times N_s \times T} = \frac{10 \times 16 \times 57.1}{8 \times 1 \times 18} = 63.4 \text{ m}^3/\text{hr}$$

C.2 Final Design Steps

C.2.1 Choose sprinkler size: From Table 4, Nozzle – 6.35 mm x 3.97 mm;
Operating Pressure – 276 kPa;
Discharge – 0.90 L/s; Wetted Diameter = 31 m

C.2.2 Determine sprinkler spacing which satisfies wind requirements in Table 1 and Table 2: Sprinkler Spacing – 12.2 m x 18.3 m

C.2.3 Since the application rate is not given. Compute using the formula given in section 10.1.3. Since the computed value is less than the soil infiltration rate, the selected sprinkler and spacing are acceptable.

$$r = \frac{q}{S_l S_m} = \frac{0.9 \frac{\text{L}}{\text{s}} \times \frac{1 \text{ m}^3}{1000 \text{ L}} \times \frac{3600 \text{ s}}{1 \text{ h}} \times \left(\frac{1000 \text{ mm}}{1 \text{ m}}\right)^3}{12.2 \text{ m} \times 18.3 \text{ m}} = 14.5 \text{ mm/h}$$

C.2.4 Set time = $\frac{d_{\text{gross}}}{r} = \frac{57.1 \text{ mm}}{14.5 \text{ mm/h}} = 3.93 \text{ h/set.}$

C.2.5 Prepare a sprinkler layout, assuming the main runs along the center of the field as shown in Figure C.1.

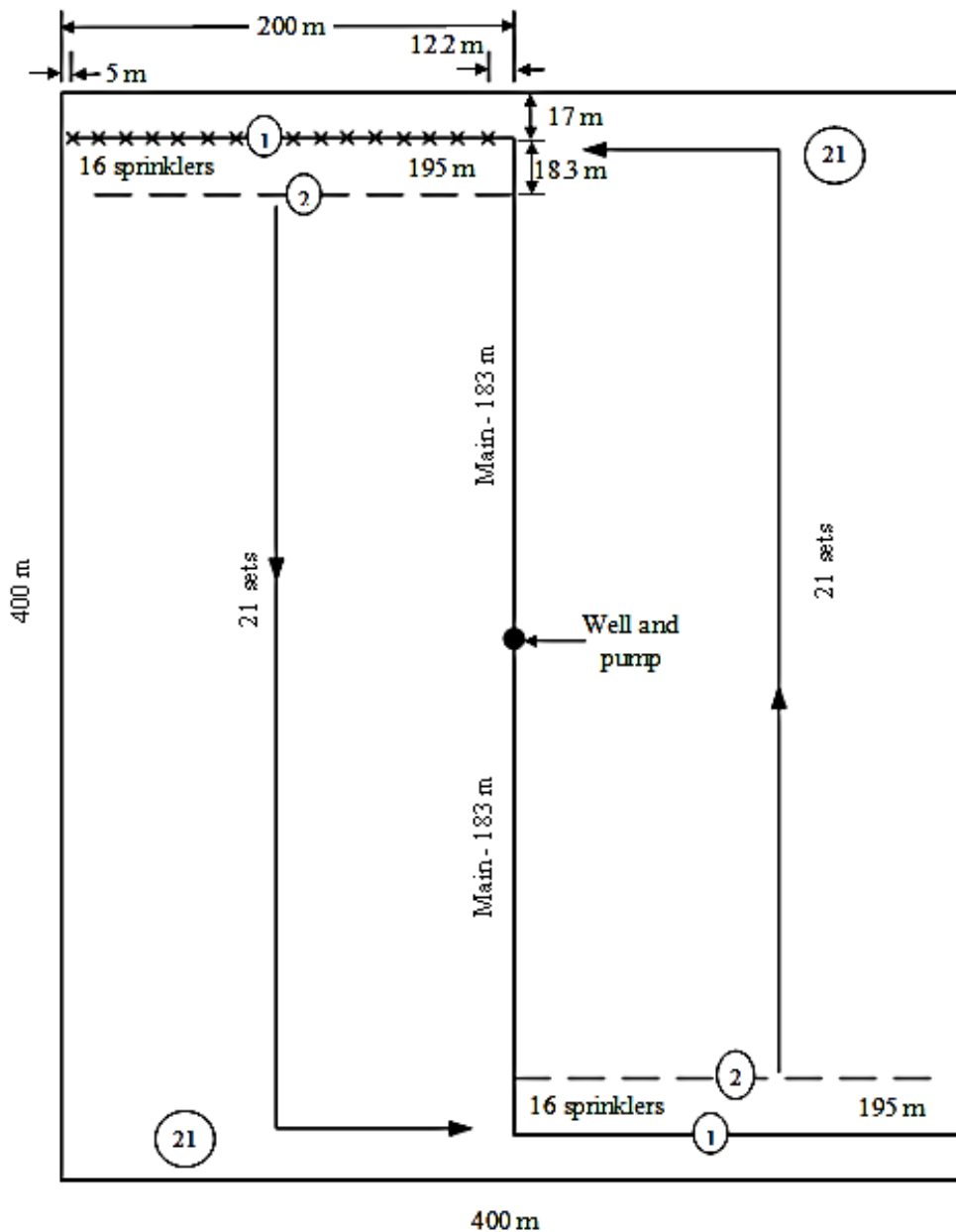

Figure C.1. Layout of Sprinkler Irrigation System

C.2.6 Number of sprinklers, $N_s = 200/12.2 = 16.4$ or 16. If the first sprinkler is 12.2 m away from the main, the 16th sprinkler is 5 m away from the boundary, spraying 10.5 m beyond the boundary. For the purpose of illustration, it will be considered fine. However, the following options may be considered:

- C.2.6.1** Move the first sprinkler to one-half the spacing from the main to reduce the overspray.
- C.2.6.2** Place a part-circle at the end of the lateral
- C.2.6.3** Remove one sprinkler from the lateral.

C.2.7 Number of lateral locations = $400/18.3 = 21.86$ or 21. Where there are 20 spaces between set locations, and the sprinklers will spray one half the wetted diameter on each side of the field, the total coverage is $366+31 = 397$ m.

C.2.8 Determine the number of laterals needed. Assuming one lateral operates per set, the irrigation time is greater than the required irrigation frequency, and no other time for repair and maintenance, choose other options.

$$\begin{aligned} \text{Irrigation Time} &= (\text{Set time} \times \text{No. of sets}) + (\text{Move Time} \times \text{No. of Moves}) \\ &= \left(3.93 \frac{\text{h}}{\text{set}} \times 42 \text{sets}\right) + \left(1 \frac{\text{h}}{\text{move}} \times 42 \text{moves}\right) = 207 \text{ h or } 8.6 \text{ days} > I_f \end{aligned}$$

C.2.8.1 Use one long lateral, with main on the side.

C.2.8.2 Use two laterals per set.

$$\text{Irrigation Time} = \left(3.93 \frac{\text{h}}{\text{set}} \times 3 \text{ set/day}\right) + \left(2 \frac{\text{h}}{\text{move}} \times 3 \text{ moves/day}\right) = 17.8 \text{ h/day}$$

$$\text{Irrigation Time} = \frac{21 \text{ sets}}{3 \text{ set/day}} = 7 \text{ days}$$

C.2.9 Compute for the system capacity.

$$Q = N_c \times N_s \times q = 2 \times 16 \times 3.24 = 103.7 \text{ m}^3/\text{hr}$$

C.2.10 Select the size of the lateral: $L_L = 195$ m, aluminum pipe, outside diameter = 101.6 mm with wall thickness = 1.83 mm.

C.2.11 Compute for the friction loss.

$$H_f = \frac{1.21 \times 10^{10} L \left(\frac{Q}{C}\right)^{1.852}}{D^{4.87}} = \frac{1.21 \times 10^{10} \times 195 \left(\frac{14.4}{120}\right)^{1.852}}{(101.6 - 2 \times 1.83)^{4.87}} = 9.37 \text{ m}$$

$$h_f = 9.37 \text{ m} \times 0.38 = 3.56$$

C.2.12 Compute for the average pressure head.

$$H_a = H_d + 0.26h_f + \frac{S_e L_L}{2} = \frac{276}{9.81} + (0.26 \times 3.56) + \frac{195}{2} = 29.1 \text{ m}$$

C.2.13 Recompute the sprinkler flow for the average pressure, application rate, friction loss in the lateral with the new average pressure.

$$q = 0.9 \left(9.81 \times \frac{29.1}{276}\right)^{0.5} = 0.915 \text{ L/s}$$

$$r = \frac{0.915 \frac{\text{L}}{\text{s}} \times \frac{1 \text{ m}^3}{1000 \text{ L}} \times \frac{3600 \text{ s}}{1 \text{ h}} \times \left(\frac{1000 \text{ mm}}{1 \text{ m}}\right)^3}{12.2 \text{ m} \times 18.3 \text{ m}} = 14.8 \text{ mm/h}$$

$$h_f = \frac{0.38 \times 1.21 \times 10^{10} \times 195 \left(\frac{14.64}{120}\right)^{1.852}}{(101.6 - 2 \times 1.83)^{4.87}} = 3.67 \text{ m}$$

$$H_a = \frac{276}{9.81} + (0.26 \times 3.67) + \frac{195}{2} = 29.08 \text{ m}$$

C.2.14 Compute for the pressure at the inlet to the lateral.

$$H_o = 29.1 + (0.74 \times 3.67) + \frac{195}{2} = 31.8 \text{ m}$$

C.2.15 Determine if the pressure variation in the lateral is less than 20% of the average pressure.

$$h_f < 0.2 \times 29.1; \text{ thus } 101.6\text{-mm lateral is acceptable}$$

C.2.16 Determine the size of the main line. $L = 183 \text{ m}$, $D_1 = 101.6 \text{ mm}$, $D_2 = 127 \text{ mm}$; wall thickness = 1.3 mm

$$H_f = \frac{1.21 \times 10^{10} L \left(\frac{Q}{C}\right)^{1.852}}{D^{4.87}} = \frac{1.21 \times 10^{10} \times 183 \left(\frac{14.4}{120}\right)^{1.852}}{(101.6 - 2 \times 1.3)^{4.87}} = 8.6 \text{ m}$$

$$H_f = \frac{1.21 \times 10^{10} L \left(\frac{Q}{C}\right)^{1.852}}{D^{4.87}} = \frac{1.21 \times 10^{10} \times 183 \left(\frac{14.4}{120}\right)^{1.852}}{(127.0 - 2 \times 1.3)^{4.87}} = 2.8 \text{ m}$$

For lower pumping costs and better uniformity, choose 127-mm pipe for the main line.

C.2.17 Determine the wheel diameter .

$$D = 1.47 \text{ m, Travel Distance} = 4 \times \pi \times 1.47 = 18.5 \text{ m}$$

$$D = 1.93 \text{ m, Travel Distance} = 3 \times \pi \times 1.93 = 18.2 \text{ m}$$

Choose 1.47-m wheel for sufficient clearance between the lateral and tomatoes, and less susceptible to wind damage or movement as well.

C.2.18 Determine the total dynamic head.

$$H_n = H_o + H_{rh} = 31.8 + 1.47/2 + 0.2 = 32.7 \text{ m}$$

$$\text{TDH} = H_n + H_m + H_j + H_s = 32.7 + 2.8 + 1.0 + 3.0 = 39.5 \text{ m}$$

C.2.19 Select the pump with the following characteristics:

Discharge Capacity: 29.3 L/s or 105.48 m³/h

TDH: 39.5 m

Efficiency: as high as possible

C.2.20 Compute for the pump power. Assuming pump efficiency of 70%

$$P = \frac{Q \times \text{TDH}}{360 \times E_p} = \frac{105.48 \times 39.5}{360 \times 0.7} = 16.53 \text{ kW}$$

**Technical Working Group (TWG) for the Development of Philippine
National Standard for Design of a Pressurized Irrigation System – Part A –
Sprinkler Irrigation**

Chair

Engr. Bonifacio S. Labiano
National Irrigation Administration

Members

Engr. Felimar M. Torizo
Board of Agricultural Engineering
Professional Regulation Commission

Dr. Teresita S. Sandoval
Bureau of Soils and Water Management
Department of Agriculture

Dr. Armando N. Espino Jr.
Central Luzon State University

Dr. Elmer D. Castillo
Philippine Society of Agricultural Engineers

Dr. Roger A. Luyun Jr.
University of the Philippines Los Baños

Engr. Francia M. Macalintal
Philippine Council for Agriculture and Fisheries
Department of Agriculture

Project Managers

Engr. Darwin C. Aranguren

Engr. Romulo E. Eusebio

Engr. Mary Louise P. Pascual

Engr. Fidelina T. Flores

Engr. Marie Jehosa B. Reyes

Ms. Micah L. Araño

Ms. Caroline D. Lat

Mr. Gerald S. Trinidad

University of the Philippines Los Baños –
Agricultural Machinery Testing and Evaluation Center