

## **Foreword**

The formulation of this national standard was initiated by the Agricultural Machinery Testing and Evaluation Center (AMTEC) under the project entitled “Enhancing the Implementation of AFMA Through Improved Agricultural Engineering Standards” which was funded by the Bureau of Agricultural Research (BAR) of the Department of Agriculture (DA).

This standard has been technically prepared in accordance with PNS 01-4:1998 (ISO/IEC Directives Part 3:1997) – Rules for the Structure and Drafting of International Standards. In compliance with metrication law “Batas Pambansa Bilang 8” enacted on January 1, 1983, some data are converted to International System of Units (SI).

The word “shall” is used to indicate requirements strictly to be followed in order to conform to the standard and from which no deviation is permitted.

The word “should” is used to indicate that among several possibilities one is recommended as particularly suitable, without mentioning or excluding others, or that certain course of action is preferred but not necessarily required.

In the preparation of this standard, the following documents/publications were considered:

Hunt, Donnel. *Farm Power and Machinery Management*. 7<sup>th</sup> Edition. Iowa State University Press, Ames, Iowa.1977.

Machinery Management Lecture Notes. Wedd, Stephen. University of Sydney, Orange. November 3, 1999.

American Society of Agricultural Engineers (ASAE) S203.10:1982 Rear Power Take-off for Agricultural Tractors

American Society of Agricultural Engineers (ASAE) S217.10:1984 Three-point Free-link Attachment for Hitching Implements to Agricultural Wheel Tractors

International Organization for Standardization (ISO) 500:1979 Agricultural Tractors – Power-take-off and drawbar – Specification

International Organization for Standardization (ISO) 500:1991 Agricultural Tractors – Rear-mounted Power-take-off – Types 1, 2 and 3

Regional Network for Agricultural Machinery (RNAM) Test Codes And Procedures for Farm Machinery. Technical Series No. 12 :1983.

Republic Act No. 7394 otherwise known as “The Consumer Act of the Philippines” enacted on July 22, 1991.

**Agricultural Machinery – Four-Wheel Tractor – Specifications**

---

**1 Scope**

This standard specifies the requirements for the construction and operation of agricultural four-wheel tractor.

This is applicable to two-wheel drive and four-wheel drive tractors with a net power range of 4 kW to 400 kW.

**2 References**

The following normative documents contain provisions, which, through reference in this text, constitute provisions of this National Standard:

PAES 102:2000, Agricultural Machinery – Operator’s Manual – Content and Presentation

PAES 103:2000, Agricultural Machinery – Method of Sampling

PAES 104:2000, Agricultural Machinery – Location and Method of Operation of Operator’s Controls – Control for Agricultural Tractors and Machinery

PAES 119:2001, Agricultural Machinery – Four-Wheel Tractor – Methods of Test

ISO 500:1991, Agricultural Tractors – Rear-mounted Power-take-off – Types 1, 2 and 3

ISO 730-1:1994, Rear-mounted three-point linkage – Categories 1, 2, 3 and 4

ISO 6489-3:1992, Agricultural Vehicles – Mechanical Connections on Towing Vehicles – Part 3: Tractor Drawbar.

ISO 3776:1989, Tractors for Agriculture – Seat Belt Anchorages.

ISO 4253:1993, Agricultural Tractors – Operator’s seating accommodation – Dimensions.

ISO/DIS 8082:2001, Roll-over Protective Structures (ROPS) – Laboratory tests and Performance Requirements.

### 3 Definitions

For the purpose of this standard, the following definitions shall apply:

#### 3.1

##### **drawbar**

bar at the rear of a tractor to which implements are hitched

#### 3.2

##### **drawbar power**

power available at the drawbar sustainable over a distance of at least 20 meters

#### 3.3

##### **four-wheel tractor**

self-propelled, wheeled vehicle having two axles designed to carry, pull or propel agricultural implements and machines

##### 3.3.1

##### **four-wheel drive**

type of four-wheel tractor where power is transmitted to all wheels

##### 3.3.2

##### **two-wheel drive**

type of four-wheel tractor where power is transmitted to rear wheels with small front wheels being pushed along

#### 3.4

##### **linchpin**

retaining pin used in the hitch pins or studs

#### 3.5

##### **lower hitch point tire clearance**

clearance (x) expressed as a radial dimension from the lower hitch point to the outside diameter of the tire with the implement in raised position and all side sway removed from the links (see Figure 1a)

#### 3.6

##### **lower hitch point tractor clearance**

horizontal dimension (z) between the rearmost parts of the tractor in the area between the two lower links and the horizontal line through the two lower hitch points throughout the range of vertical movement of the hitch points (see Figure 1b)

NOTE The power-take-off master shield may be removed, if necessary to meet this dimension.

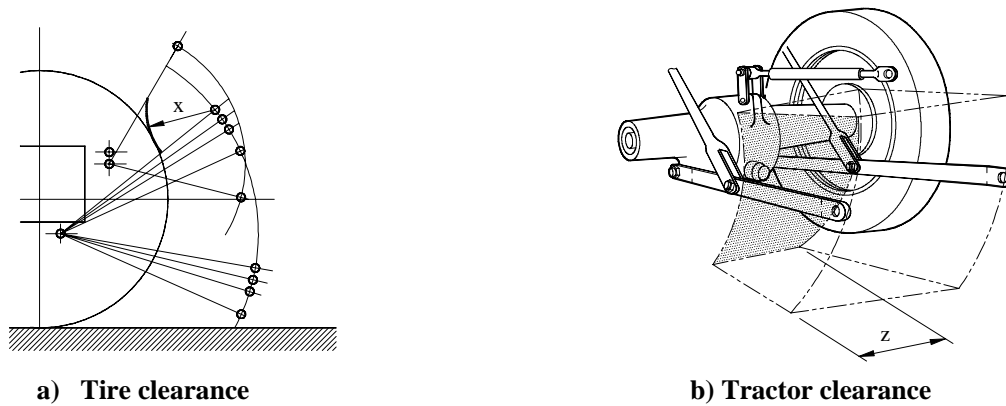

**Figure 1 – Lower Hitch Point Tire and Tractor Clearance**

### 3.7

#### **power-take-off (PTO) shaft**

external shaft usually at the rear of the tractor providing rotational power to implements and machines

### 3.8

#### **PTO output power**

power measured at the PTO shaft

### 3.9

#### **roll-over protective structure (ROPS)**

roll-over protective device (ROPD)

safety frame

two- or four-post structural frames primarily used to protect a seat-belted operator from being crushed in case the machine rolls over

### 3.10

#### **three-point linkage**

combination of one upper link and two lower links, each articulated to the tractor and the implement at opposite ends in order to connect the implement to the tractor (see Figure 2)

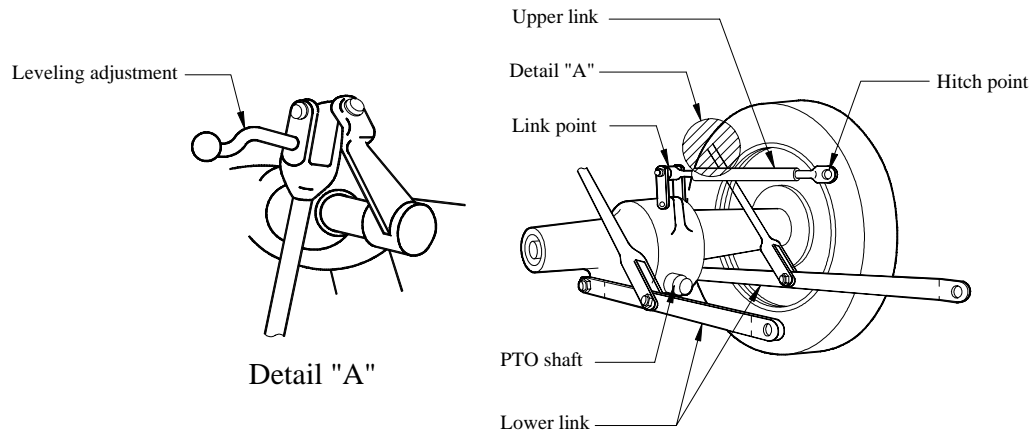

**Figure 2 – Three-point Linkage and its Components**

### **3.10.1**

#### **hitch point**

articulated connection between a link and the implement (see Figure 2)

NOTE For geometrical analysis, the hitch point is established as the center of the articulated connection between a link and the implement.

### **3.10.2**

#### **leveling adjustment**

adjustment of the right lower link so that the hitch point may be moved vertically with respect to the left lower hitch point to provide an inclination of the implement (see Figure 2)

### **3.10.3**

#### **link point**

articulated connection between a link and the tractor (see Figure 2)

NOTE For geometrical analysis, the link point is established as the center of the articulated connection between a link and the tractor.

### **3.10.4**

#### **upper hitch pin**

pin that connects the upper link to the implement (see Figure 2)

### **3.10.5**

#### **upper link pin**

pin that connects the upper link to the tractor (see Figure 2)

### **3.11**

#### **wheel tread**

center to center distance between two front or rear wheels

## **4 Classification**

**4.1** two-wheel drive

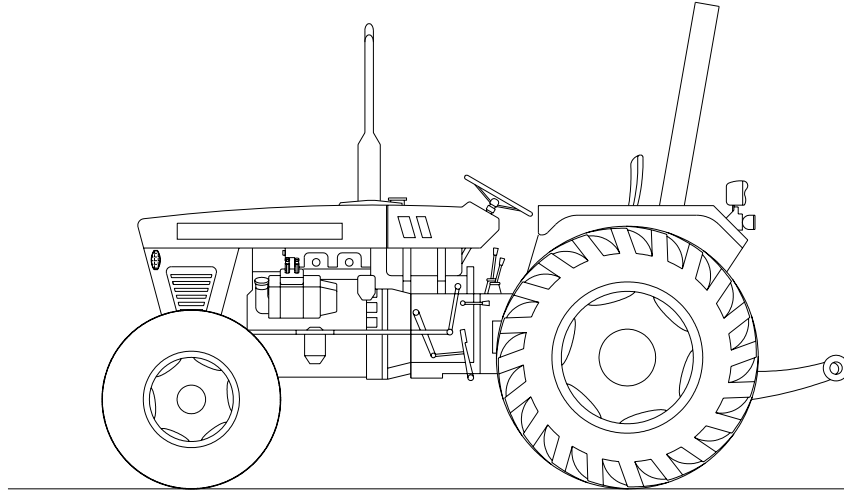

**Figure 3. Two-wheel drive tractor**

**4.2** four-wheel drive

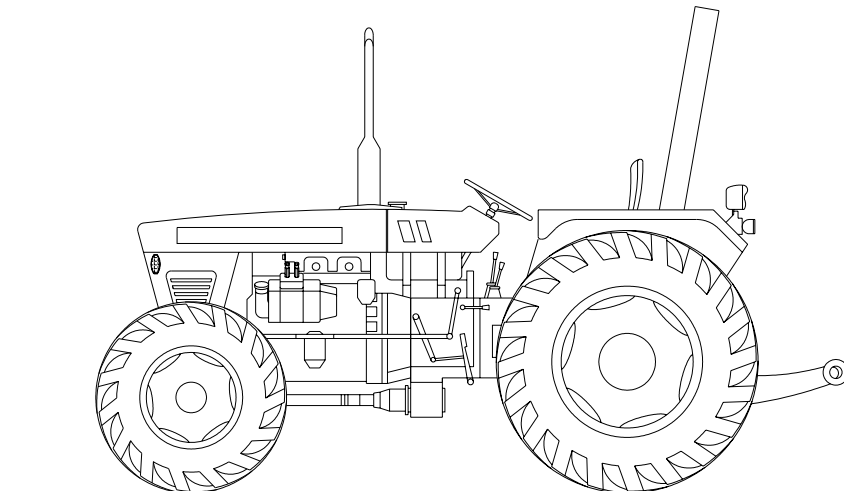

**Figure 4. Four-wheel drive tractor**

**5 Construction Requirements**

**5.1 Materials**

The tractor shall be generally made of cast iron and steel materials.

**5.2 Controls**

The various controls of the tractor as shown in Figure 5 shall be located and operated in accordance with PAES 104.

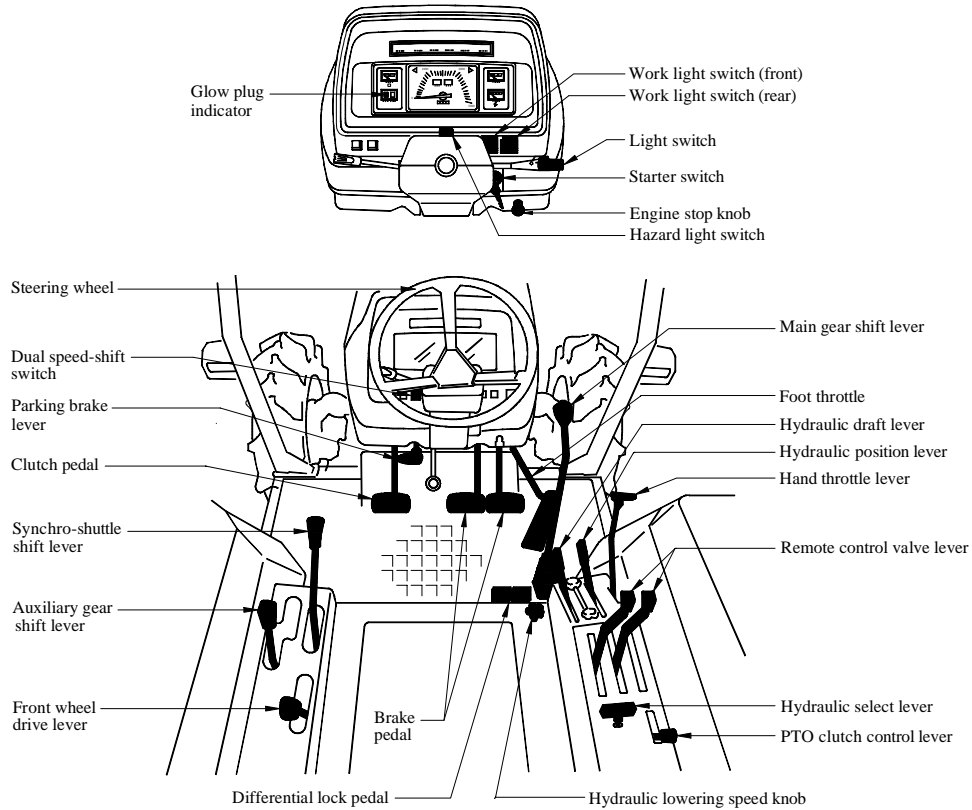

**Figure 5. Typical controls of a four-wheel tractor**

**5.3 Hydraulic Three-point Linkage System**

**5.3.1** The tractor shall be equipped with position and/or draft implement controls.

**5.3.2** The dimensions of three-point linkage shall be based on the following categories to enable implements to be attached to all makes of tractors. Each category covers tractor power ranges as shown in Table 1.

**Table 1 – Three-point Linkage Categories**

Category	Maximum Drawbar Power kW
1	15 – 35
2	30 – 75
3	60 – 168
4	135 – 300

Source: ASAE Standard 209, Agricultural Tractor Test Code.

NOTE For more detailed specifications of three-point linkage refer to ISO 730-1.

**5.3.3** The dimensions associated with the tractor is given in Table 2 and shown in Figure 6.

**Table 2 – Dimensions Associated with the Tractor under the three-point linkage categories**

Dimensions in millimeters

	Category 1		Category 2		Category 3		Category 4	
	Min	Max	Min	Max	Min	Max	Min	Max
<b>Upper Link*</b>								
Width at hitch point (C)	-	44	-	51	-	51	-	64
Radius at hitch point (E)	-	51	-	51	-	51	-	64
Hitch pin hole diameter (B)	19	20	25	26	32	33	45	46
<b>Upper Hitch Pin</b>								
Diameter (A)	18	19	25	26	31	32	44	45
Distance from head to centerline of linchpin hole (D)	92	-	102	-	102	-	140	-
Linchpin hole diameter (G)	11	12	11	12	11	12	17	18
<b>Lower Link</b>								
Width at hitch point (J)	34	35	34	45	44	45	57	58
Radius at hitch point (F)	-	45	-	67	-	76	-	76
Stud hole diameter (H)	22	23	28	29	36	37	51	52
Lower hitch point tire clearance (X)	76	-	76	-	76	-	76	-
Lower hitch point tractor clearance (Z)	457	-	457	-	457	-	457	-
Side sway at hitch point each side of center position with lower links horizontal‡ (RR)	102	-	127	-	127	-	127	-
Horizontal distance from end of PTO shaft to lower hitch points with draft links horizontal§ (Y)	508	559	508	559	508	559	508	559

\* Side sway of the upper link must be compatible with that provided at the lower links plus necessary allowance for lateral adjustment.

‡ Means should be provided to lock the draft links in a rigid lateral position for PTO, for other operations where side sway cannot be tolerated

and when the hitched is raised to the transport position. No maximum dimensions for side sway are specified; this must be limited in each individual application so that hitch or implement will not come in contact with the tractor tires.

§ Dimensions pertain to 1-3/8 and 1-3/4 in. diameter, 540 rpm PTO shafts and 1-3/8 in. diameter, 1000 rpm PTO shafts. On some previously

designed models of tractors, the minimum horizontal distance for Category 1 and Category 2 is 457 mm (18 in.). Dimensions shown should be

increased by 102 mm (4 in) on tractors equipped with 1-3/4 in. diameter, 1000 rpm PTO shafts.

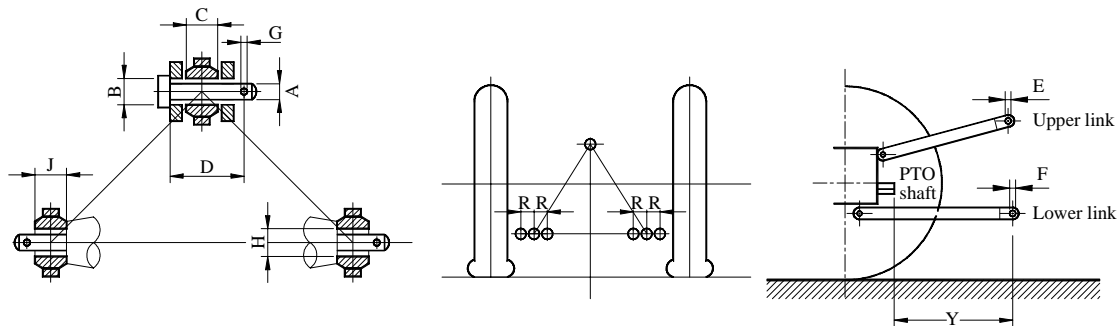
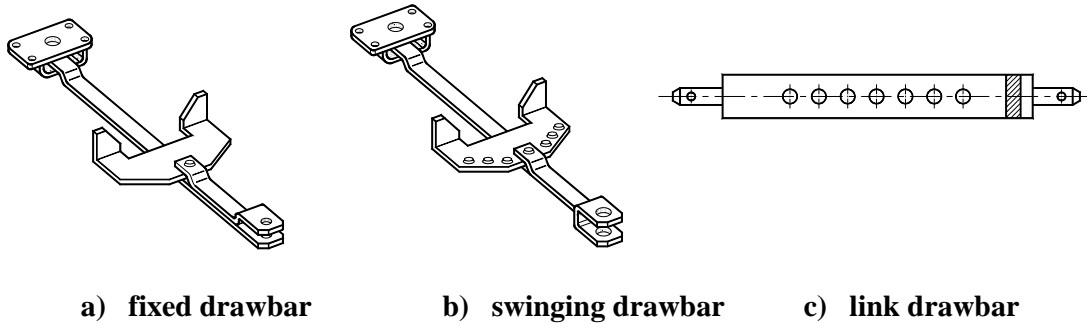

**Figure 6 – Dimensions Associated with the Tractor**



## 5.4 Drawbar

### 5.4.1 Types of drawbar



**Figure 7 –Drawbar types**

**5.4.2** The drawbar shall be situated in the longitudinal mid-plane of the tractor. The diameter of the hole in the drawbar should be  $36_{-0.1}^0$  mm. The thickness of the drawbar shall be not more than 32 mm. (see Figure 8)

NOTE For more detailed specification of drawbar refer to ISO 6489-3.

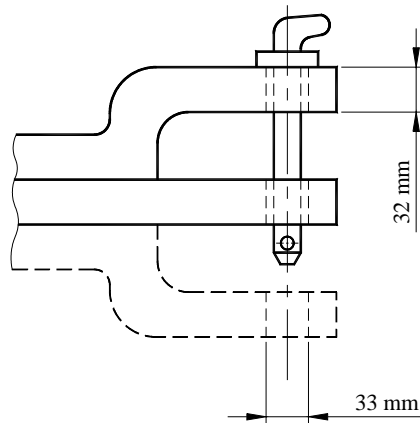

**Figure 8 – Clevis-type drawbar hole diameter and thickness**

**5.4.3** Mechanism for drawbar height adjustment shall be provided, as this can be useful for setting up the implement for the most efficient output.

## 5.5 Transmission systems

### 5.5.1 Main clutch and PTO clutch

#### 5.5.1.1 Dry type single-plate clutch

The clutch is engaged when the driven plate is gripped firmly between the flywheel and pressure plate by the force of the pressure spring causing the rotary motion of the flywheel to be transmitted through driven plate to main drive shaft. (see Figure 9a)

Applying a stepping force on the clutch pedal causes the rod to move in the direction of the arrow accompanying the leftward movement of the release bearing so that the lower end of the release lever is pushed in the same direction. The pressure plate is shifted toward the right against the force of the pressure spring removing the pressure from the driven plate so that transmission of the revolution of the flywheel to the driven plate is cut bringing the main shaft to a halt. (see Figure 9b)

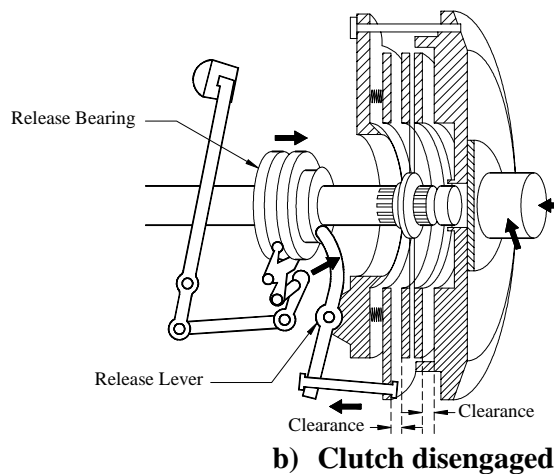
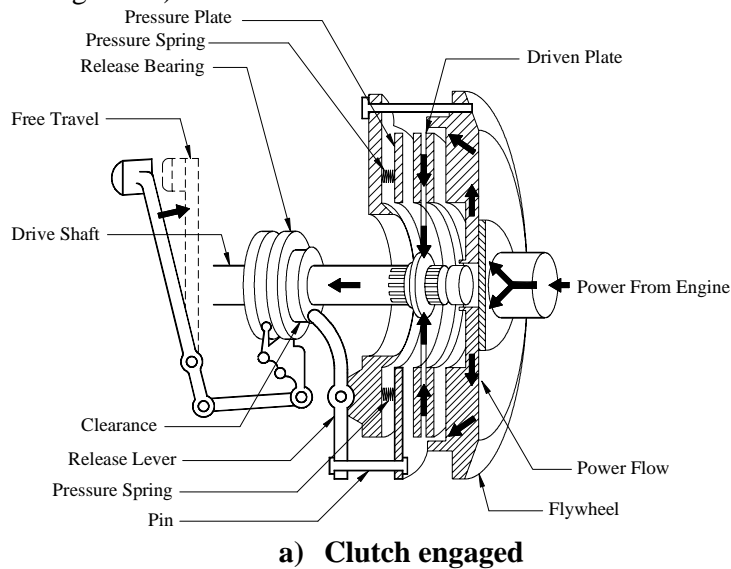

**Figure 9 – Dry Type Single-plate Clutch**

**5.5.1.2 Dual clutch**

When both the main clutch and dual clutch parts are both engaged, the main clutch disc and PTO clutch disc are transmitting power to the main driving shaft and PTO driving shaft, respectively. (see Figure 10a)

The first stage of stepping on the clutch pedal causes the pin to move in the direction of the arrow, but the original space between the pin (2) and the pressure plate (1) is wide enough to prevent the pin (2) from pulling the pressure plate. However, the pin (1) pushes the pressure plate towards the flywheel side until it comes apart from the main clutch disc. Thus, the first stage recession of the clutch pedal disengages the main clutch part while the PTO clutch is still engaged. (see Figure 10b)

The second stage of stepping on the clutch pedal deeper down causes the pin (2) to pull the pressure plate (1) away from the PTO clutch disc making both the PTO clutch and main clutch disengaged. (see Figure 10c)

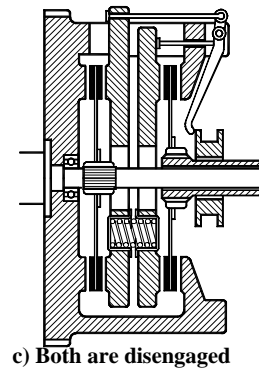
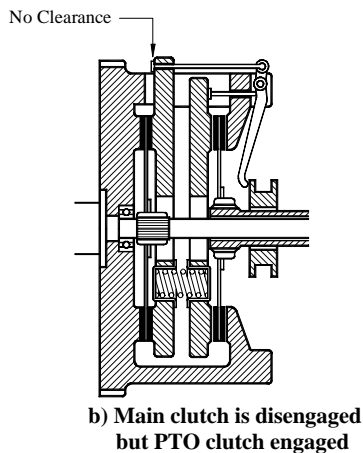
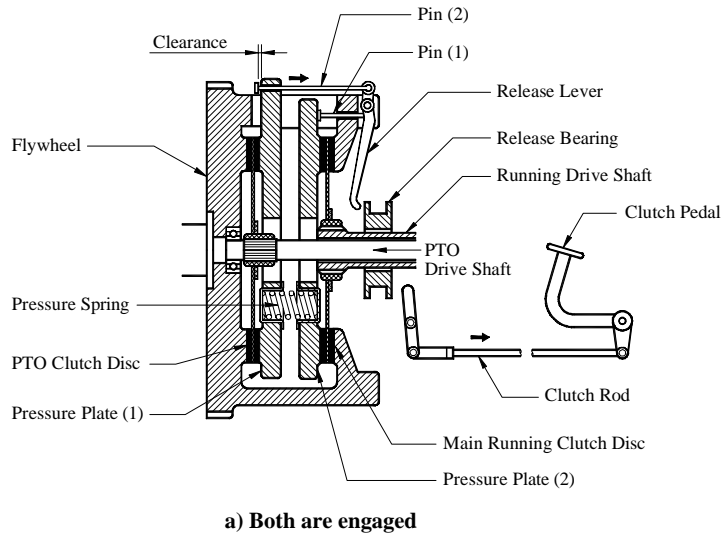

**Figure 10 – Construction and Function of Dual Clutch**

**5.5.2 Transmission gears**

The transmission gears shall be classified based on the following:

**5.5.2.1 Sliding mesh gears**

Gears on the main shaft are meshed with the other gears on the counter shaft selectively by sliding them along the splined part of the gear. (see Figure 11)

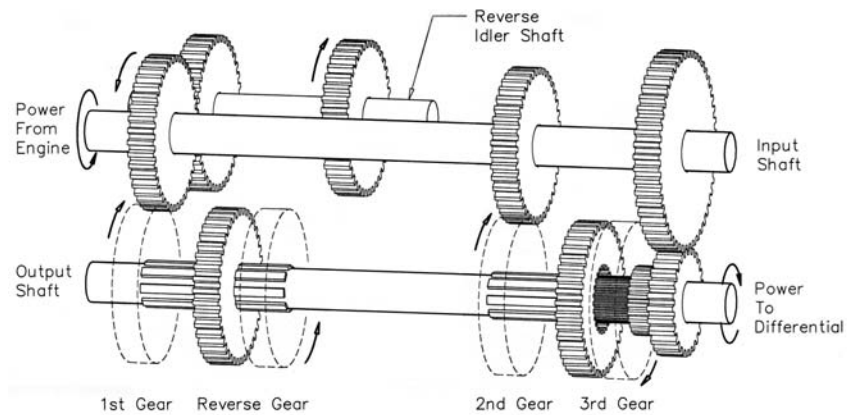

**Figure 11**

**Mesh Type Transmission Gears**

– Sliding

**5.5.2.2 Constant mesh gears**

A gear on the counter shaft and an idler on the main shaft are kept in constant mesh, while the sliding clutch (1) and (2) on the splined part of the main shaft are connected with the gears by sliding them along to drive the main shaft. To attain the main shaft's maximum speed, the drive shaft shall be directly connected to the main shaft by sliding clutch (1) to the left. If the mating clutch (1) is shifted to the right connecting it to gear 2, the main shaft will assume the same speed as the gear 2. Similarly, when the mating clutch (2) is shifted to the left connecting it with gear 3, the main shaft's revolution will be reversed. (see Figure 12)

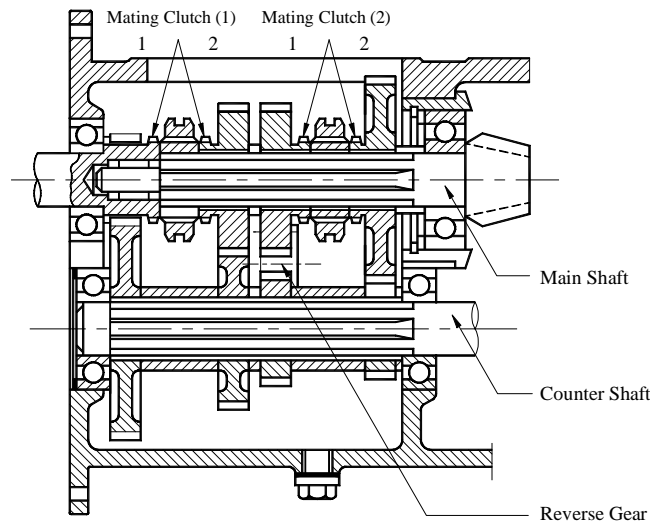

**Figure 12 – Constant mesh type transmission gears**

**5.5.2.3 Synchronous mesh gears**

**5.5.2.3.1 Constant load type**

Cone clutches are formed between the inner part of the hub and the mating gears (1) and (2). Mating of the clutch is done by moving the sleeve axially which gives sliding motion to the hub via the steel balls along the main shaft. By mating of the friction clutch, the revolution of the gear and the main shaft are made uniform.

If the sleeve is pushed further after giving same revolution to the gear and the main shaft, the steel balls are displaced from the grooves causing the sleeve to slide on the hub resulting in smooth meshing between the clutching gear and interval splines of the sleeve. (see Figure 13a)

**5.5.2.3.2 Inertia lock type**

The clutch is engaged when the sliding ring is moved by shift lever, the fixed collar moves together by spring force and its end face presses against the cone. Differential revolution speed, if any, between the gears (1) and (2) and the main shaft causes the cone to rotate in one way until it halts by the side face of the fixed collar. And the more the sliding ring of the teeth of the cone are pressed, the more the cone is pressed by cam lift generating frictional torque in the cone clutch which result in the synchronizing action. When the speed of the main shaft and the gear (1) or (2) is equalized, the torque given by cone clutch to rotate the cone is lifted and the sliding ring returns the cone to its neutral position passes the teeth and meshes with the clutching teeth of the gear (1) or (2). (see Figure 13b)

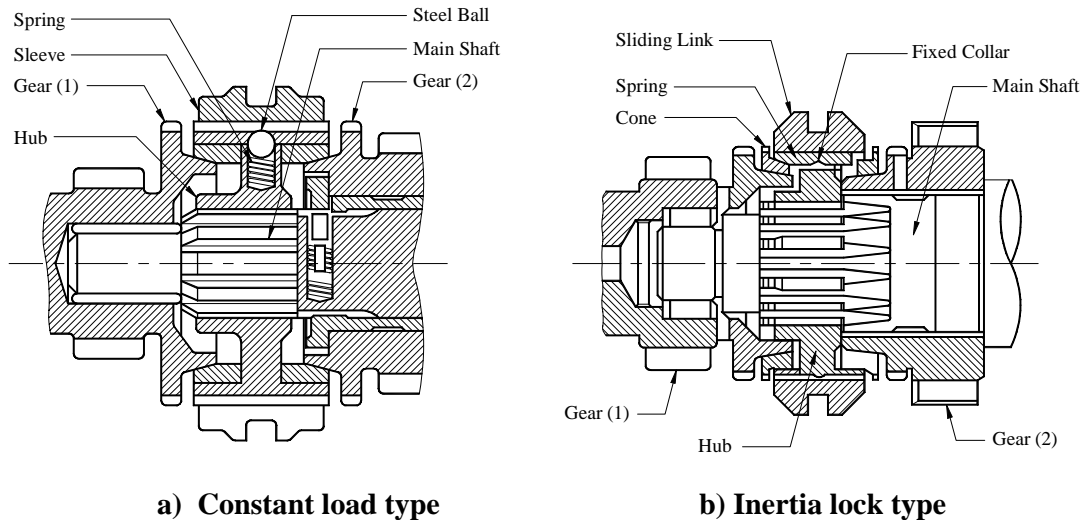
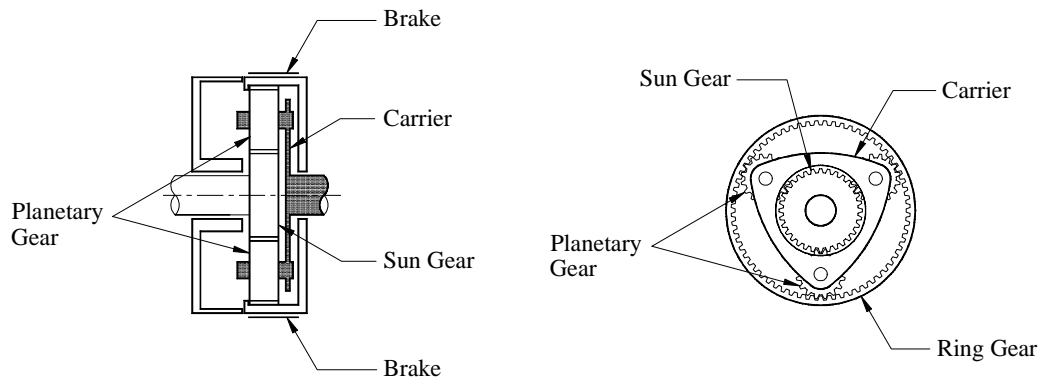

**Figure 13 – Synchronous Mesh Type Transmission Gears**

### 5.5.2.4 Planetary gears

It is composed of the sun gear fixed on the driving shaft; the planetary gear which is meshed with it; the carrier fixed on the driving shaft which supports them; the ring gear on the internal side of which the planetary gears are in mesh; and the brake for locking the ring gear.

When the ring gear is locked and the sun gear is driven by the driving shaft, the planetary gears will rotate around the sun gear, at the same time, spinning by themselves, and the carrier rotates in the same direction. (see Figure 14)



**Figure 14 – Principles of Planetary Speed Change Gears**

### 5.5.2.5 Fluid coupler and transmission

In hydrostatic transmission (HST), the plunger or gear pump delivers liquid to the hydraulic motor which is similar to the pump in construction (see Figure 15). The HST makes use of a small volume of liquid at high pressure for power transmission.

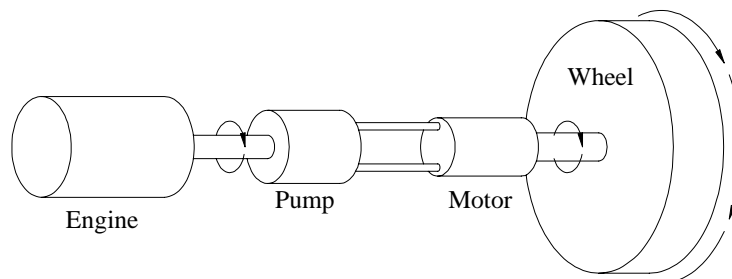
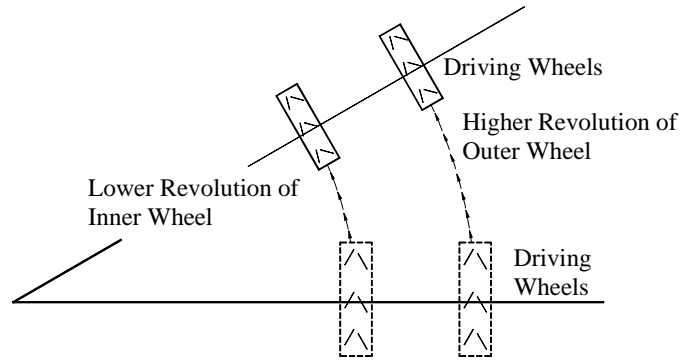

**Figure 15 – Hydrostatic Transmission (HST)**

5.5.2.6 Tractors may have “on-the-go” shifts and/or shuttle gears which enable quick forward and reverse selection in each gear.

### 5.5.3 Differential gears

When the tractor is turning (see Figure 16a), the resistance against the inner wheel becomes greater than the resistance against the outer wheel, the difference of which is reflected to the differential side gear as a corresponding differential resistance. This differential resistance causes the differential pinions to turn giving different rotating speeds to the differential side gear, resulting to different rotating speeds of the right and left driving wheels. (see Figure 16b)



a) Function

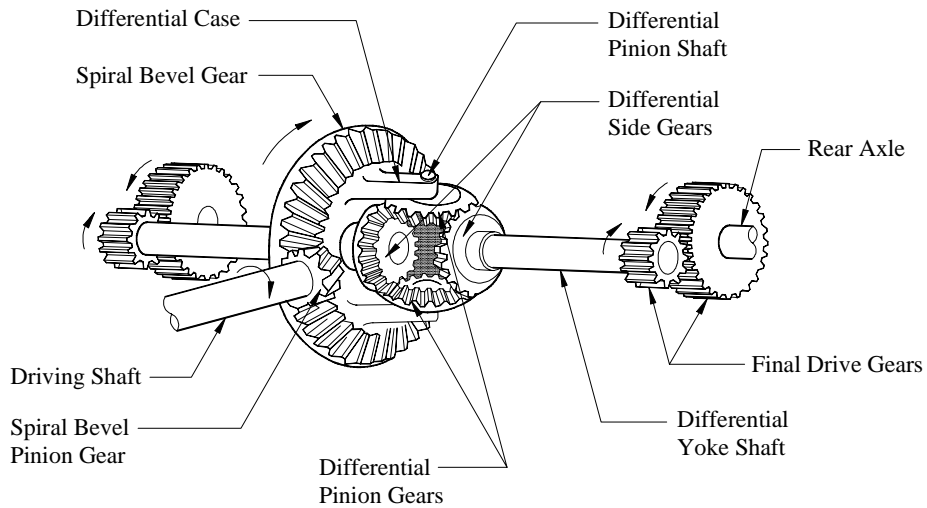

b) Construction

**Figure 16 – Function and Construction of Differential Gears**

**5.5.4 Differential lock**

The differential lock is a device by which a restraining force is applied to the differential gears in case one of the wheels go into an idle spin, so that the differential yoke shafts are rotated together as one unit. (see Figure 17)

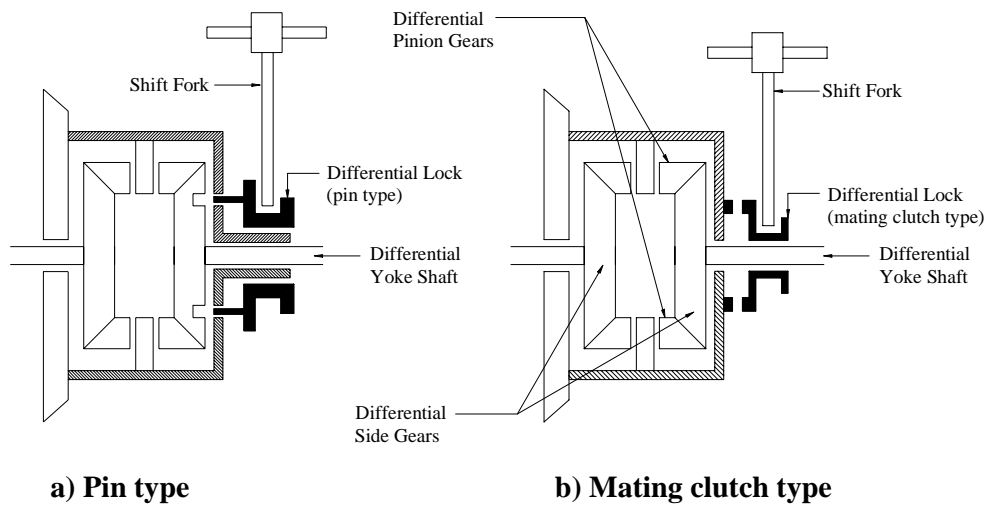

**Figure 17 – Types of Differential Locks**

**5.5.6 PTO shaft**

The main characteristics of the three types of PTO shafts shall be as specified in Table 3.

**Table 3 – Characteristics of PTO Types**

PTO Type	Nominal Diameter mm	Number and Type of Splines	PTO Rated Speed rpm	PTO Shaft Profile
1	35	6 straight splines	540	

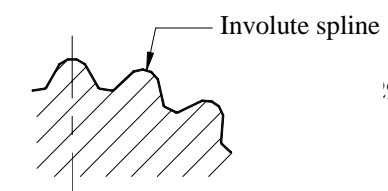



2	35	21 involute splines	1000	
3	45	20 involute splines	1000	

NOTE For more detailed specifications of the PTO, refer to ISO 500.

**5.6 Wheel tread adjustment**

Mechanism for wheel tread adjustment shall be provided, as this can be useful for allowing the wheel tread to be matched with implements.

**5.6.1 Front tread**

The length of the front axle itself shall be adjusted by changing set bolt positions as shown in Figure 18a. The length of the tie-rod shall be adjusted accordingly. For four-wheel drive tractors, the front tread shall be adjusted by inverting the disc or changing the position of the wheel hub along the shaft as shown in Figure 18b.

**5.6.2 Rear tread**

For two-wheel and four-wheel drive tractors, the rear tread shall be adjusted by inverting the disc, since the shaft length is not changeable. Or, it shall be adjusted by changing the position of the wheel hub along the shaft. (see Figure 18b)

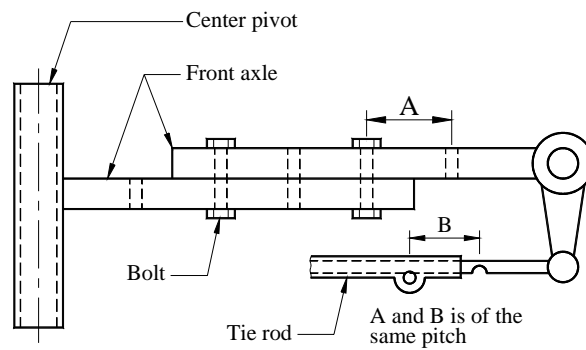

**a) Tread adjustment of front wheel**

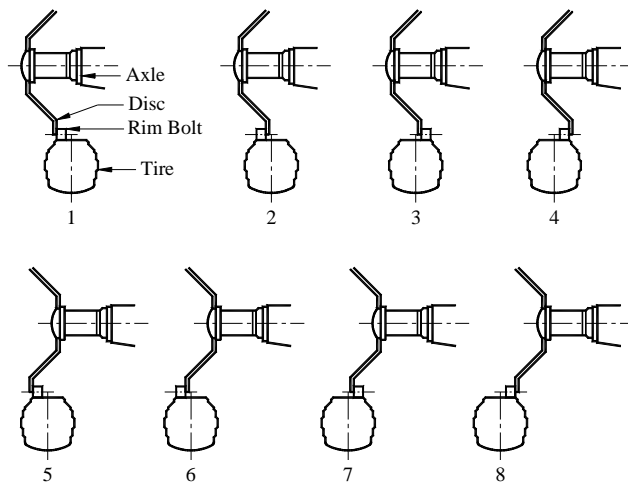

**b) Tread adjustment of rear wheels**

**Figure 18 – Examples of Wheel Tread Adjustment**

**5.7 Brake system**

The brake system shall be classified according to:

**5.7.1 manner of applying braking force**

**5.7.1.1 internal expansion type**

The motion of the brake cam in the direction of the arrow makes the brake shoes open outward until the brake linings are pressed hard against the brake drum for braking (see Figure 19 a).

**5.7.1.2 external contraction type**

The motion of the link arm in the direction of the arrow makes the brake band tightly in contact with the brake drum for braking (see Figure 19 b).

**5.7.1.3 disc type**

The steel balls between the two actuating discs pushed them outward until they are pressed hard against the brake discs for braking (see Figure 19 c).

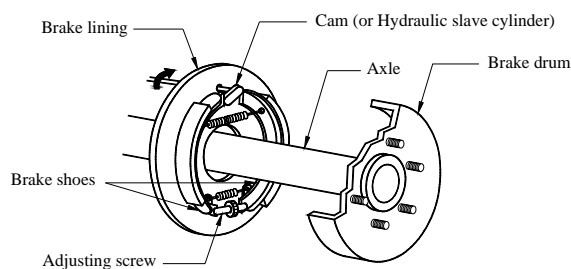

**a) internal expansion type**

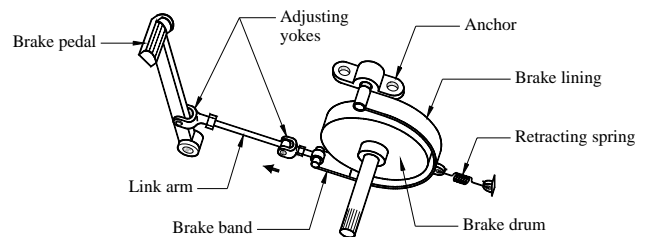

**b) external contraction type**

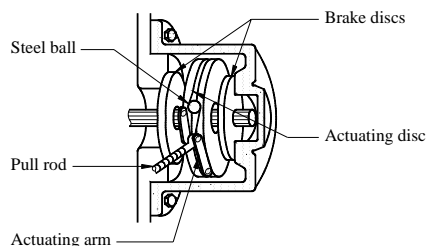

c) disc type

Figure 19 – Types of Brake based on Brake Force Application

5.7.2 manner of transmitting the force from the control

5.7.2.1 mechanical brake

The motion of the brake rod in the direction of the arrow is transmitted through the brake lever to rotate the brake cam for braking. (see Figure 20a)

5.7.2.2 hydraulic brake

The stepping force on the brake pedal is converted to hydraulic forces by the master cylinder and then transmitted through the pipe to the wheel cylinder. (see Figure 20b)

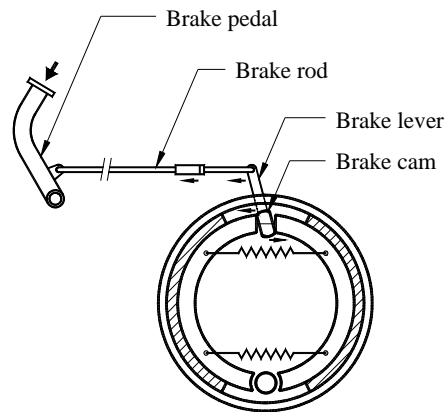

a) mechanical brake

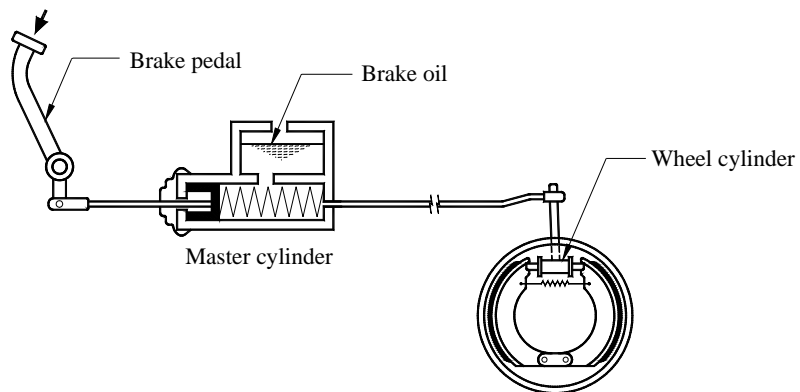

## b) hydraulic brake

**Figure 20 – Types of Brake based on Brake Force Transmission****6 Performance Requirements**

**6.1** The drawbar power and field performance shall be tested in accordance with PAES 119.

**6.2** The allowable wheel slip for maximum efficiency is shown in Table 4.

**Table 4 – Acceptable Level of Wheel slip**

<b>Tractor type</b>	<b>Firm Soil %</b>	<b>Tilled or Soft Soil %</b>
<b>Two-wheel drive</b>	7 – 11	10 – 15
<b>Four-wheel drive</b>	6 – 10	8 – 13

Source: Machinery Management Notes #1 – Traction.

**6.3** The tractor equipped with three-point linkage shall have the minimum hydraulic lift force capacity available throughout the power range, at a distance of 610 mm beyond the lower hitch points (without external assist hydraulic cylinders) as shown in Table 5.

**Table 5 – Hydraulic Lift Force Capacity**

<b>Maximum drawbar power kW</b>	<b>Lift force per drawbar power* kN/kW</b>
65 and below	0.31
Above 65	20.15 plus 0.155 kN/kW for the succeeding drawbar power

Source: ASAE Standard S217.10, Three-point Free-link Attachment for Hitching Implements to Agricultural Wheel Tractors

**6.4 Tractor speed during field operations**

The tractor shall be able to pull field implements up to 8 km/h.

**7 Safety Requirements**

**7.7.1** When the PTO is in use, a cover or casing that protects the sides of the PTO shaft shall be fitted. An additional non-rotating casing shall also be provided when the PTO is not in use. This casing shall enclose the PTO shaft completely and be fixed to the tractor body.

**7.7.2** A seat shall be provided which will adequately support the operator in all working and operating modes. Adequate and comfortable support and protection for the feet shall be provided.

NOTE For more detailed specification of seat and ROPS refer to ISO 4253 and ISO/DIS 8082, respectively.

**7.7.3** All tractors powered by 15 kW engines or higher shall be equipped with ROPS and seat belts.

NOTE For more detailed specification of seat belt refer to ISO 3776.

**7.7.4** The noise emitted by the tractor measured 50 mm away from the operator's ear level shall not be more than 92 db (A).\*

## **8 Other Requirement**

**8.1** The engine of the tractor shall be equipped with cooling system suitable for tropical operations.

**8.2** Mechanism that minimize/reduce vibration shall be provided.

## **9 Workmanship and Finish**

**9.1** The tractor shall be free from manufacturing defects that may be detrimental to its operation.

**9.2** Any uncoated metallic surface shall be free from rust and shall be painted properly.

**9.3** The tractor shall be free from sharp edges and surfaces that may injure the operator.

## **10 Warranty for Construction and Durability**

**10.1** Warranty against defective materials and workmanship shall be provided for parts and services except for consumable maintenance parts (i.e. fan belts, oil filter, fuel filter, etc.) within six (6) months from the purchase of the tractor.

**10.2** The construction shall be rigid and durable without breakdown of its major components (i.e. transmission, cooling, lubrication systems, etc) within six (6) months from purchase by the first buyer.

## **11 Maintenance and Operation**

**11.1** Each tractor unit shall be provided with the following minimum quantity of basic hand tools: three (3) pieces open wrenches, one (1) piece each of Philips and flat screw driver, one (1) pair of mechanical pliers, one (1) piece adjustable wrench, one (1) piece grease gun, one (1) piece of tire wrench and one (1) piece of lifting jack.

\* Allowable noise level for six (6) hours of continuous exposure based on Occupational Safety and Health Standards, Ministry of Labor, Philippines. 1983.

**11.2** An instruction manual, which conforms to PAES 102, shall be provided.

**11.3** All components that require regular maintenance, servicing and adjustment should be easily accessible.

## **12 Sampling**

The tractor shall be sampled for testing in accordance with PAES 103.

## **13 Testing**

The sampled tractor shall be tested in accordance with PAES 119.

## **14 Marking and Labeling**

Each tractor shall be marked in English language with the following information using a plate, stencil or by directly punching it at the most conspicuous place:

**14.1** Registered trademark of the manufacturer

**14.2** Brand

**14.3** Model

**14.4** Serial number

**14.5** Name and address of manufacturer

**14.6** Name and address of importer (optional)

**14.7** Country of manufacture

**14.8** Safety/precautionary markings