

Foreword

The formulation of this national standard was initiated by the Agricultural Machinery Testing and Evaluation Center (AMTEC) under the project entitled "Enhancing the Implementation of AFMA Through Improved Agricultural Engineering Standards" which was funded by the Bureau of Agricultural Research (BAR) of the Department of Agriculture (DA).

This standard has been technically prepared in accordance with PNS 01-4:1998 (ISO/IEC Directives Part 3:1997) – Rules for the Structure and Drafting of International Standards.

The word “shall” is used to indicate requirements strictly to be followed in order to conform to the standard and from which no deviation is permitted.

The word “should” is used to indicate that among several possibilities one is recommended as particularly suitable, without mentioning or excluding others, or that certain course of action is preferred but not necessarily required.

In the preparation of this standard, the following documents/publications were considered:

Regional Network for Agricultural Machinery (RNAM) Test Codes And Procedures for Farm Machinery. Technical Series No. 12 :1983.

Stevens G.N. *Equipment Testing and Evaluation*. Overall Division, National Institute of Agricultural Engineering (NIAE), Wrest Park, Silsoe Bedford England. 1982.

Smith, D.W., Sims B.G, and D.H. O’Neill. *Testing and Evaluation of Agricultural Machinery and Equipment – Principles and practices*. FAO Agricultural Services Bulletin 110. 1994.

Agricultural Machinery – Seeder and Planter – Specifications

1 Scope

This standard specifies the requirements for construction and performance of various types of grain seeders with or without fertilizer applicator. This standard is not applicable to wetland seeder and planter.

2 References

The following normative document contains provisions, which, through reference in this text, constitute provisions of this National Standard:

PAES 102:2000, Agricultural Machinery – Operator’s Manual – Content and Presentation

PAES 103:2000, Agricultural Machinery – Method of Sampling

PAES 123:2001, Agricultural Machinery – Seeder and Planter – Methods of Test

3 Definition

For the purpose of this standard, the following definitions shall apply:

3.1**grain seeder**

seeder

planting equipment used to deposit seeds in the soil for crop production

NOTE It can be a manually-operated, animal-drawn or tractor power-driven seeder.

3.2**field efficiency**

ratio of effective field capacity to the theoretical field capacity

NOTE The field efficiency is determined by the following formula:

$$E_f = \frac{efc}{tfc} \times 100$$

where: E_f is the field efficiency, %
 efc is the effective field capacity, m²/h
 tfc is the theoretical field capacity, m²/h

3.3**effective field capacity**

actual rate of being able to plant a given area per unit of time

NOTE The time pertains to the actual time which includes the time spent for turning at headland, adjustment of machine and machine trouble.

3.4**theoretical field capacity**

computed rate of being able to plant a given area per unit of time

3.5**seed delivery rate**

amount of seeds that can be planted per unit area

4 Classification**4.1 Manually-operated or hand seeder (Figure 1)**

This is a type of seeder which deposits the seeds in holes with spacing set by the operator.

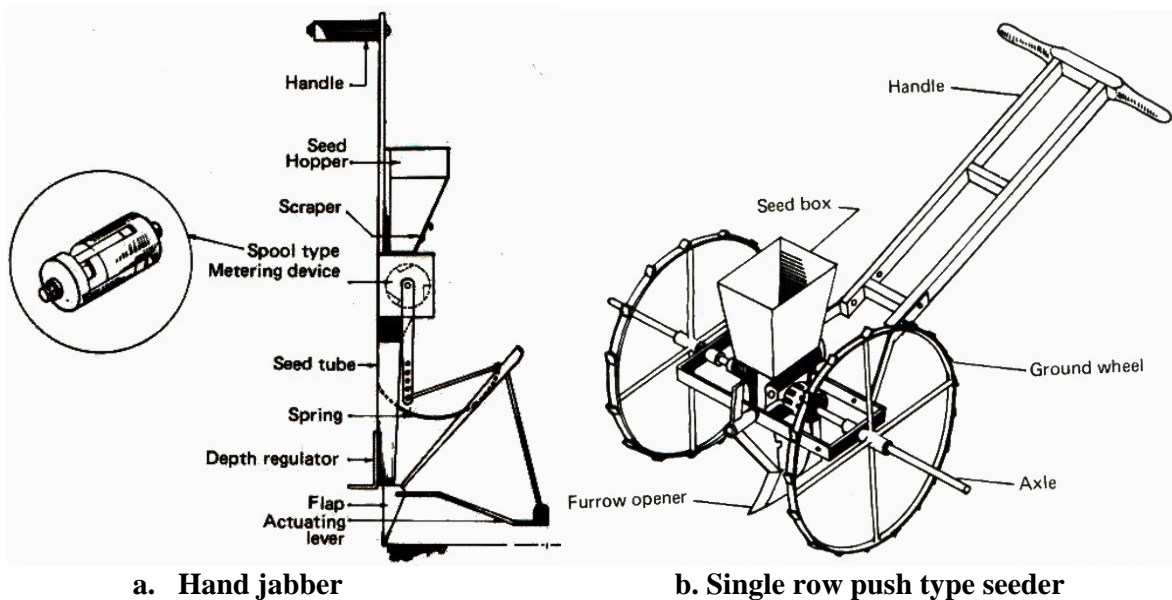

Figure 1 – Manually-Operated Seeder

4.2 Animal-drawn seeder (see Figure 2)

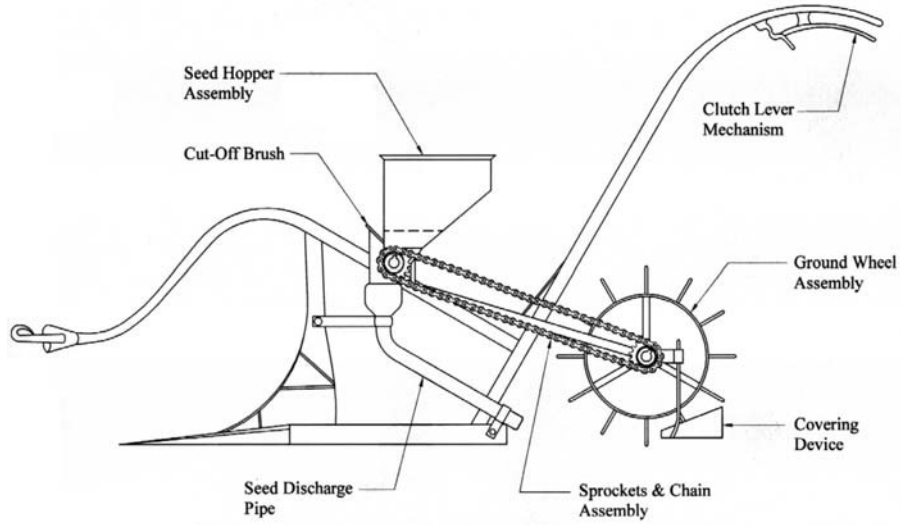

Figure 2 – Animal-Drawn Seeder

4.3 Tractor power-driven seeder and planter

This is a type of seeder with metering mechanisms driven by the ground wheels or by power-take-off from a tractor

4.3.1 Seed drill

This is a type of tractor power-driven seeder which drills and deposits the seeds at a specified rate and depth and in narrow-spaced rows. It cannot deposit the seeds in hills or even in check rows. (see Figure 3 and Figure 4)

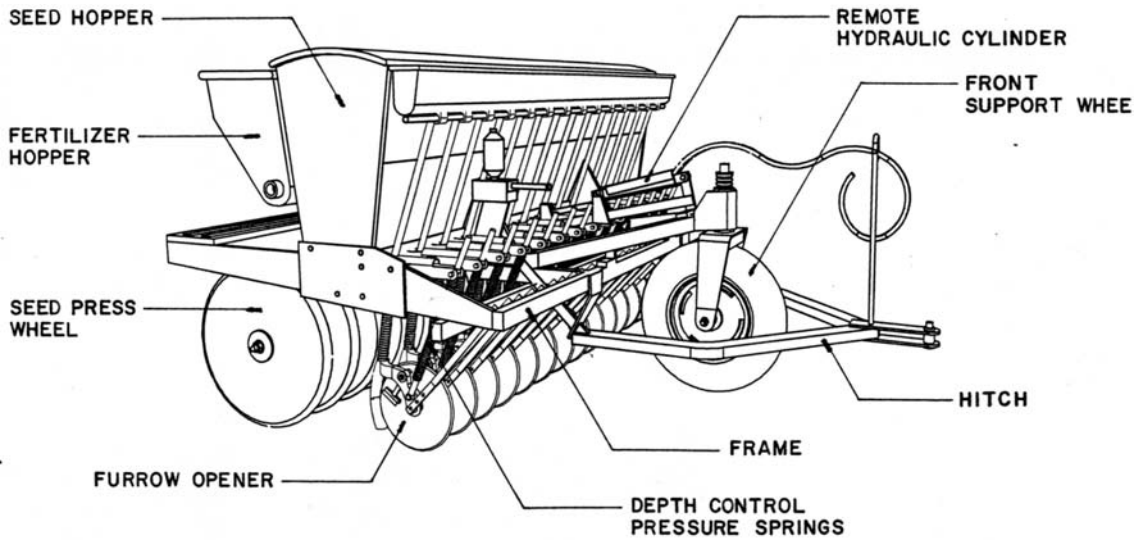

Figure 3 – Tractor-trailed seed drill with fertilizer applicator

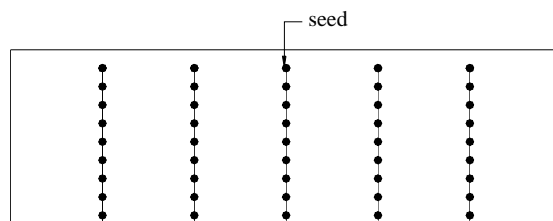

Figure 4 – Seeding Pattern of a Drill Planter

4.3.2 Row-crop planter

This is a type of tractor power-driven seeder which can deposit the seeds at a specified rate in hills and rows spaced to permit inter-row cultivation and also functions as a seed drill if required. (see Figure 5)

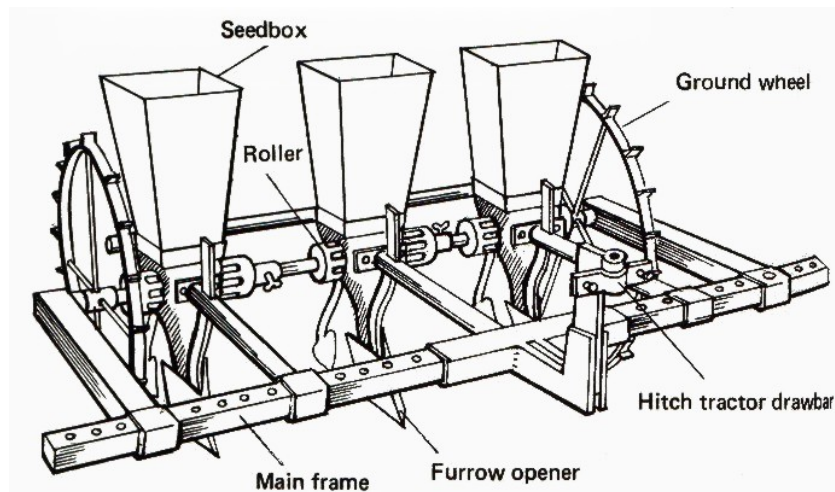

Figure 5 – Three-row planter for walking tractor

4.3.2.1 Hill-drop planter

This is a type of row-crop planter which is designed to deposit one or more seeds in a hill at equal intervals. (see Figure 6)

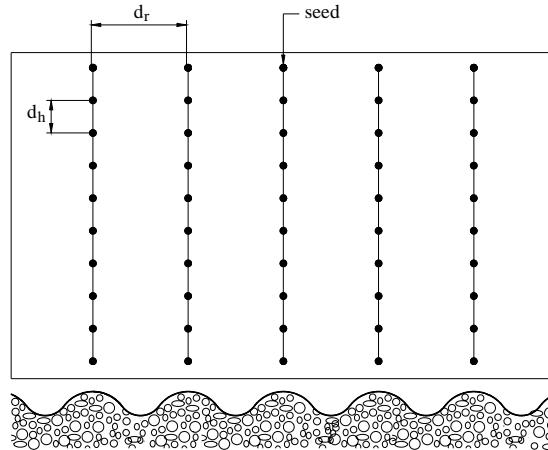

Figure 6 – Seeding Pattern of a Hill-drop Planter

NOTE d_r is the distance between rows
 d_h is the distance between hills at equal intervals
 d_r is not equal to d_h

4.3.2.2 Checkrow planter

This is a type of row-crop planter which enables operator to perform hill planting at definite spacing (in checks or squares). This facilitates mechanical weed control and other operations. (see Figure 7)

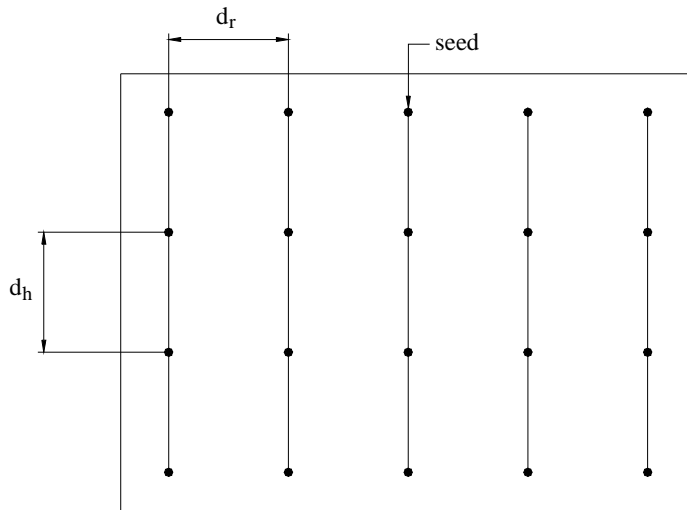

Figure 7 – Seeding Pattern of Checkrow Planter

NOTE d_r is the distance between rows
 d_h is the distance between hills at equal intervals
 d_r is equal to d_h

4.3.2.3 Precision planter

This is a type of row-crop planter which is designed to deposit a single seed at equal row intervals.

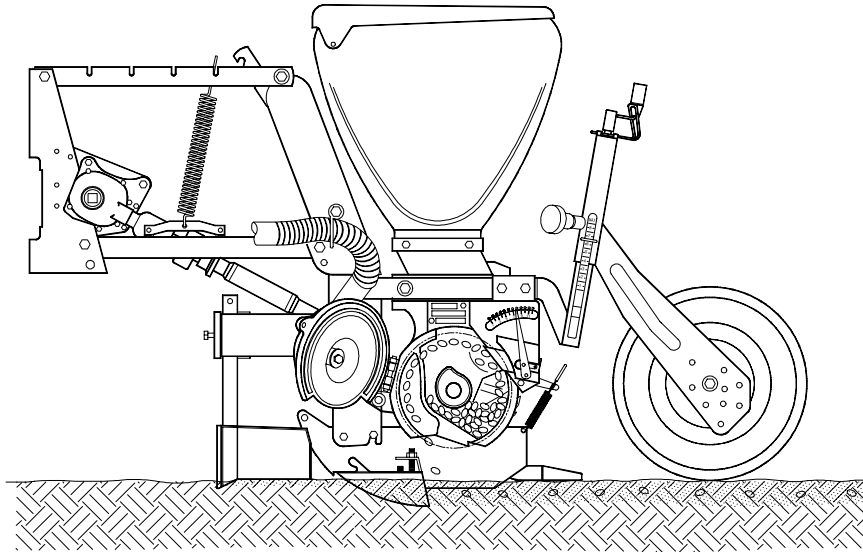

Figure 8 – Precision planter without fertilizer applicator

5 Materials of Construction

The seeder and planter shall be generally made of steel and/or plastic.

6 Construction Requirements

- 6.1** The seed plate shall be replaceable.
- 6.2** Seeders shall be provided with control to adjust seed depth.
- 6.3** Hoppers shall be designed to contain seed/fertilizer with minimum frequency of refilling during operation.
- 6.4** Multi-row seeder shall have
 - 6.4.1** adjustable row spacing
 - 6.4.2** independent suspension for each row planter
- 6.5** For four-wheel tractor mounted/trailed seeders, these may be provided with seed drop sensors and monitor.
- 6.6** For seeder with fertilizer applicator, it shall be

6.6.1 provided with adjustable fertilizer metering and depth of delivery control

6.6.2 designed to place the seed and fertilizer so they will not be in contact with each other.

7 Performance Requirements

7.1 The working capacity and delivery rate specified by the manufacturer shall be attained.

7.2 The seeder shall have the capability to provide uniform seed placement even in a not so well prepared seedbed/land.

7.3 During operation, the seeder shall produce good quality work such as accuracy and uniformity of seed and/or fertilizer placement, ease of operation and maintenance, evenness of spacing, and minimum seed damage.

7.4 Tractor power-driven seeders shall have field efficiencies as shown in Table 1.

Table 1 – Required Minimum Efficiency for Tractor Power-Driven Seeder

Type of seeder	Field Efficiency (%)
Row-crop planter	
Without fertilizer applicator	60
With fertilizer applicator	55
Seed drill	65

8 Other Requirements

The seeder shall be easy to operate such as:

8.1 hitching to and unhitching from the tractor;

8.2 adjusting the depth of planting;

8.3 ease of handling and operation; and

8.4 clearing blockages.

9 Workmanship and Finish

9.1 The seeder shall be free from manufacturing defects that may be detrimental to its operation.

9.2 Any uncoated metallic surface shall be free from rust and shall be painted properly.

9.3 The seeder shall be free from sharp edges and surfaces that may injure the operator.

10 Warranty for Construction and Durability

10.1 The construction shall be rigid and durable without major breakdown of its major components within six (6) months.

10.2 Warranty shall be provided for parts and services within six (6) months after the purchase of the seeder, except for fast moving and easy to wear parts such as seals.

11 Maintenance and Operation

11.1 A set of tools required for adjustment during field operations shall be provided.

11.2 An instruction manual, which conforms to PAES 102, shall be provided.

12 Sampling

The seeder shall be sampled in accordance with PAES 103.

13 Test Method

The sampled seeder shall be tested for performance and durability in accordance with PAES 123.

14 Marking and Labeling

Each seeder shall be marked in English with the following information using a plate, stencil or by directly punching it at the most conspicuous place:

14.1 Registered Trademark of the Manufacturer

14.2 Brand

14.3 Model

14.4 Type

14.5 Serial number

14.5 Name and address of the manufacturer

14.6 Name and address of the importer, if imported (optional)

14.7 Country of manufacture (if imported) / “Made in the Philippines” (if manufactured in the Philippines)

14.8 Safety/precautionary markings