

Foreword

The formulation of this National Standard was initiated by the Agricultural Machinery Testing and Evaluation Center (AMTEC) under the project entitled "Enhancing the Implementation of AFMA Through Improved Agricultural Engineering Standards" which was funded by the Bureau of Agricultural Research (BAR) of the Department of Agriculture (DA).

This Standard was reviewed by the Technical Committee for Study 2 – Development of Standards for Engineering Materials and was circulated to various private and government agencies/organizations concerned for their comments and reactions. These standards were presented to the Philippine Society of Agricultural Engineers (PSAE) and subjected to a public hearing organized by the National Agriculture and Fisheries Council (NAFC). The comments and reactions received during the presentation and public hearing were taken into consideration in the finalization of the standards.

This Standard has been technically formulated in accordance with PNS 01:Part 4:1998 – Rules for the Structure and Drafting of Philippine National Standard. It provides specifications and proper application of drives using flat belts and does not cover manufacturing specifications.

In the preparation of this standard, the following references were considered.

Baumeister, Theodore (ed.) 1997. Mark's handbook for mechanical engineers. 10th Edition. Mc Graw Hill Book Company, USA.

Carmichael, C. (ed.) 1950. Kent's Mechanical engineer's handbook. Design and production volume. 12th Edition. John Wiley and Sons, Inc., USA.

Horton, H. L. (Ed.) 1984. Machinery's handbook. 23rd Edition. Industrial press inc., New York.

PNS 647:1990, Specification for pulleys for flat transmission belts

Shigley, Joseph, E. 1989. Mechanical engineering design. 3rd Edition. Mc Graw Hill Book Company, USA.

Mitsuboshi Design Manuals

Engineering Materials – Flat Belts and Pulleys for Agricultural Machines – Specifications and Applications

1 Scope

This Standard establishes specifications and provides technical information for the proper application of flat belts and pulleys for drives in agricultural machinery.

2 Reference

The following normative references contains provisions which, through reference in this text, constitute provisions of this Standard:

PAES 304:2000, Engineering Materials – Keys and Keyways for Agricultural Machines – Specifications and Applications

3 Application

Flat belts are commonly used where center distances between pulleys are fairly long. They are very flexible and can transmit power in quarter twist and crossed drives.

4 Definitions

4.1

flat belt

belts used to transmit rotary motion and power between two shafts, which lie flat on the face of its corresponding pulley

4.2

flat belt pulley

wheel having flat or crowned face used to transmit motion and power by means of flat belts

4.3

flat belt drive

power transmission device used to transmit power and motion between two shafts consisting of flat belts which ride in flat pulleys

4.4

pulley diameter

outside diameter of the pulley

4.5

belt length

stretched-out length of the belt

4.6

speed ratio

ratio of the angular velocities of the pulleys making no allowance for slip and creep

4.7

belt speed

the linear speed of the belt calculated by multiplying the rpm and the diameter of the driver pulley and to the value of pi

5 Flat belts

5.1 Nomenclature

Dimensions of flat belts are designated by its width (W), and by its thickness (t).

5.2 Materials

Flat belts for agricultural machinery are usually made of rubberized cord and fabric and reinforced nylon cords. Flat belts may be spliced to obtain the desired loop size or made as a continuous loop. They can be arranged in layers or in plies.

5.3 Rubberized fabric

5.3.1 Description

Rubber belting is made from fabric or cord, impregnated and bound together by vulcanized rubber compounds. Advantages are high tensile strength, strength to hold metal fasteners satisfactorily and resistance to deterioration by moisture. Rubber belts are used in places exposed to the weather or the action of steams.

5.3.2 Specifications

Table 1 specifies the power rating (in watts per millimeter of belt width) for rubber belts given the number of ply and the types of rubber used while Table 2 specifies the minimum recommended diameters for rubber belts. Minimum and maximum number of ply is specified in Table 3.

Table 1 – Power rating of rubber belts (watts per mm of belt width)

Belt speed, m/min	Number of ply (Fabric belt)						Number of ply (Hard fabric belt)								Number of ply (Rayon cord belt)					
	3	4	5	6	7	8	3	4	5	6	7	8	9	10	3	4	5	6	7	8
152	21	26	35	41	47	53	21	29	38	44	50	56	62	68	47	62	76	91	106	120
305	41	56	68	82	94	106	44	59	73	88	103	117	132	147	91	120	150	182	211	241
457	62	82	100	120	138	156	65	88	109	132	153	173	194	214	135	179	223	270	314	358
610	79	106	132	159	182	206	85	114	144	173	203	232	261	288	176	235	297	355	414	476
762	97	129	161	194	226	255	103	138	173	208	244	279	311	343	214	288	361	435	511	584
914	114	153	191	229	264	299	120	161	203	244	285	326	364	402	252	338	426	514	599	687
1,219	144	191	238	282	329	373	150	200	250	299	349	399	449	499	311	426	537	649	763	875
1,524	164	217	270	323	376	429	170	229	288	343	399	455	511	567	352	487	619	755	890	1,022
1,829	176	232	288	343	399	455	182	244	292	343	399	455	511	567	373	523	675	825	975	1,127
2,134							179	238	297	355	414	470	526	581	361	523	690	848	1,013	1,174
2,438							161	214	264	314	364	414	464	514	314	481	652	819	989	1,157

Table 2 – Minimum pulley diameters for rubber belts (mm)

Belt speed, m/min	Number of ply (Fabric belt)						Number of ply (Hard fabric belt)								Number of ply (Rayon cord belt)					
	3	4	5	6	7	8	3	4	5	6	7	8	9	10	3	4	5	6	7	8
152	102	102	152	229	330	457	76	102	127	152	254	356	457	559	127	178	229	330	406	483
305	102	127	178	254	356	483	76	102	152	203	305	406	508	610	152	203	254	406	432	508
457	102	152	229	279	406	533	76	127	178	254	381	432	533	635	178	229	279	381	457	559
610	102	152	254	330	432	559	102	127	203	279	381	457	559	660	178	229	305	406	483	584
762	127	178	254	356	457	584	102	152	203	279	381	483	584	686	203	254	330	406	508	584
914	127	178	279	381	483	635	102	152	229	305	406	508	635	711	203	279	330	432	533	610
1,219	127	203	305	406	533	635	102	178	254	330	432	533	635	737	229	305	381	457	559	635

1,524	152	229	330	457	559	686	127	178	279	381	483	584	686	787	254	305	406	483	584	660
1,829	152	254	356	483	610	737	127	203	305	406	508	610	711	838	279	356	432	533	610	711
2,134							152	229	330	457	559	686	787	889	305	381	483	584	660	762
2,438							178	305	406	533	660	787	914	1,041	330	432	533	635	737	838

Table 3 – Minimum and maximum plies of rubber belting

Width, mm	Minimum number of plies	Maximum number of plies	Width, mm	Minimum number of plies	Maximum number of plies
51	3	4	406	5	8
76	3	4	457	5	8
102	3	5	508	5	8
127	4	5	559	5	8
152	4	6	607	5	8
203	4	6	660	6	8
254	4	6	762	6	10
305	4	6	914	6	10
356	5	8	1,067	6	10

5.4 Nylon cord belts

5.4.1 Description

Nylon cord belts are endless belts made with single ply high tensile cords. They are oil and heat resistant. Their thin dimension allows them to be in smaller pulleys and with high-speed drives.

5.4.2 Specifications

Tables 4, 5, and 6 specify the power rating of different types of nylon cord belts. Tables 7 and 8 specify the standard width and length of flat cord belts respectively.

Table 4 – Power rating of section light capacity nylon cord belts, W

rpm of smaller pulley	Diameter of smaller pulley, mm										
	16	18	20	22	25	28	32	36	40	45	50
400	15	23	23	30	30	38	45	53	60	68	75
1,200	45	60	68	80	100	120	140	170	180	210	230
4,000	160	200	230	270	330	390	470	540	610	680	750
6,000	230	290	350	400	490	580	690	800	890	1,000	1,100
8,000	310	380	450	530	650	760	910	1,050	1,170	1,300	1,420
10,000	380	470	560	650	800	940	1,120	1,280	1,420	1,560	1,700
14,000	530	650	770	890	1,070	1,260	1,480	1,680	1,830	1,970	2,070
18,000	660	800	950	1,100	1,320	1,530	1,780	1,970	2,090	2,150	2,150
20,000	730	880	1,040	1,190	1,430	1,640	1,880	2,060	2,150	2,150	2,040

Table 5 – Power rating of section medium capacity nylon cord belts, W

rpm of smaller pulley	Diameter of smaller pulley, mm									
	40	45	50	56	63	71	80	90	100	
300	53	75	90	120	150	180	21	230	260	
900	160	220	280	360	440	530	620	700	770	
1,500	260	360	470	590	740	890	1,030	1,160	1,280	
3,000	520	710	920	1,180	1,460	1,760	2,030	2,270	2,510	
4,500	770	1,060	1,370	1,740	2,160	2,600	2,980	3,310	3,630	
6,000	1,010	1,390	1,790	2,270	2,820	3,370	3,840	4,230	4,590	
7,500	1,230	1,700	2,190	2,780	3,420	4,070	4,590	5,000	5,330	
10,500	1,630	2,240	2,870	3,620	4,410	5,150	5,650	5,880	5,950	
13,500	1,920	2,650	3,370	4,190	5,030	5,690	5,930			
15,000	2,030	2,780	3,530	4,360	5,150	5,710				

Table 6 – Power rating of section high capacity nylon cord belts, W

rpm of smaller pulley	Diameter of smaller pulley, mm								
	80	90	100	112	125	140	160	180	200
200	150	190	230	270	320	370	430	480	530
600	450	560	670	800	950	1,100	1,280	1,440	1,600
1,000	750	920	1,110	1,340	1,570	1,830	2,130	2,390	2,650
2,000	1,490	1,840	2,200	2,630	3,100	3,590	4,160	4,640	5,100
3,000	2,200	2,710	3,230	3,860	4,520	5,230	5,990	6,610	7,170
4,000	2,870	3,530	4,200	5,000	5,810	6,660	7,520	8,150	8,660
5,000	3,500	4,280	5,070	5,990	6,920	7,830	8,660	9,140	9,380

Table 7 – Width for nylon cord belts and min. allowable pulley diameter, mm

Belt cross section	Thickness	Min. allowable diameter	Recommendable diameter	Width
Light capacity	1.5	16	25	10, 15, 20, 25, 30, 35, 40, 50
Medium capacity	2.5	40	56	20, 30, 40, 50, 60, 80, 100
Heavy capacity	3.5	80	125	50, 75, 100, 125, 150, 175, 200

Table 8 – Belt lengths, mm

Inside length	Belt cross section			Inside length	Belt cross section			Inside length	Belt cross section		
	Light	Medium	Heavy		Light	Medium	Heavy		Light	Medium	Heavy
200	*			670	*	*		1,400	*	*	*
224	*			710	*	*		1,500	*	*	*
250	*			750	*	*		1,600	*	*	*
280	*			800	*	*	*	1,700	*	*	*
315	*			850	*	*	*	1,800	*	*	*
355	*			900	*	*	*	1,900	*	*	*
400	*			950	*	*	*	2,000	*	*	*
450	*			1,000	*	*	*	2,240		*	*
500	*	*		1,060	*	*	*	2,500		*	*
530	*	*		1,120	*	*	*	2,800		*	*
560	*	*		1,180	*	*	*	3,150		*	*
600	*	*		1,250	*	*	*	3,550		*	*
630	*	*		1,320	*	*	*	4,000		*	*

* Indicates that such length is available.

5.5 Markings

5.5.1 The following information shall be marked on the belt:

- 1) Type of belt and its width (for endless nylon cord belts, length is indicated)
- 2) Manufacturer’s name and/or its trademark

5.5.2 The following information shall be marked on the packaging:

- 1) Type of belt and its width (for endless nylon cord belts, length is indicated)
- 2) Manufacturer’s name, trademark, and address

6 Flat-pulleys

6.1 Nomenclature

Figure 1 shows the designation of dimensions of pulleys.

6.2 Classification

Pulleys shall be classified into solid and split, by construction and into crown and level by the shape of external peripheral face (shown in Figure 1). Symbols indicating the classification are as follows:

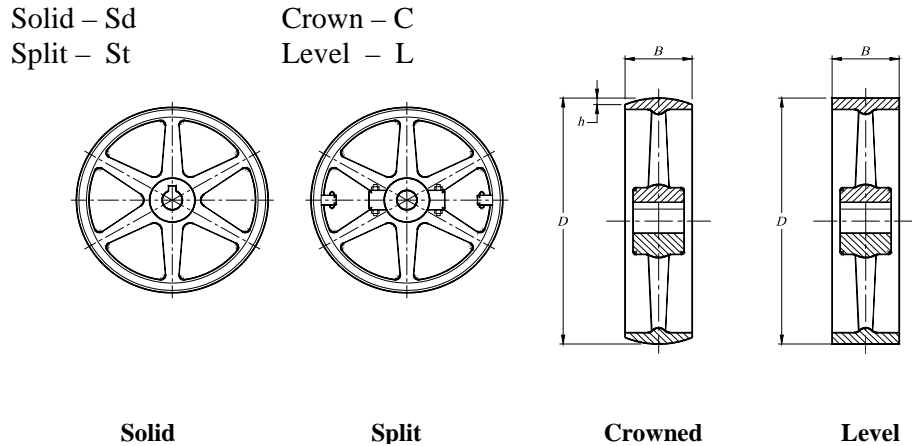

Where:

- B is the pulley face width
- h is the crown height
- D is pulley diameter

Figure 1 – Classification and designation of dimensions of flat pulleys

6.3 Materials

Flat pulleys are usually made of cast iron or fabricated steel.

6.4 Specifications

6.4.1 Pulley face width, B is nominally the same as the width of the belts they are to carry. However, allowances should be made to ensure that the belt stays in the pulley. Minimum pulley diameters for rubber belts are given in Table 2. Allowances for pulley width for different belt width are given in Table 9.

Table 9 – Allowances for pulley width

Belt width, mm	Allowance, mm
Under 305	25
305 to 610	51
Over 610	76

6.4.2 Belts are made to center themselves in their pulleys by the use of crowned pulleys. The usual figure for the amount of crowning (h), is one percent or the pulley width.

6.4.3 Dimensions of flat pulleys are specified in Table 10.

Table 10 – Dimensions of flat pulleys, mm

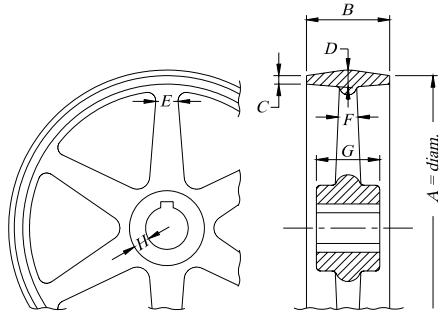

A	B	C	D	E	F	G	H
152	102	3	5	19	11	76	10
152	152	3	5	19	11	89	13
152	203	3	5	19	11	89	13
152	305	3	5	19	11	102	13
203	102	3	5	21	11	76	10
203	152	3	5	21	11	89	13
203	203	4	6	27	14	114	13
203	305	4	6	27	14	140	13
254	102	3	5	24	14	76	13
254	152	4	6	27	14	89	13
254	203	4	6	27	14	114	13
254	305	4	6	33	16	140	16
305	102	4	6	25	11	83	13
305	152	4	6	44	13	102	13
305	203	4	6	44	13	127	16
305	305	5	8	38	19	165	16
356	102	4	6	34	13	89	13
356	152	4	6	34	13	114	16
356	203	5	8	33	14	127	16
356	305	5	8	43	21	165	16
406	102	4	6	35	14	89	13
406	203	5	8	37	16	127	16
406	305	6	9	37	16	165	19
406	406	6	9	48	24	210	22
457	102	5	8	33	14	102	16
457	203	6	9	38	17	140	19
457	305	6	9	34	17	184	22
457	508	6	10	57	32	229	22
508	102	5	8	35	16	102	16
508	203	5	8	35	16	127	19
508	305	6	9	41	19	178	19
508	508	7	11	57	29	254	25
559	102	5	8	38	16	102	16
559	203	5	8	38	16	127	19
559	305	6	9	44	21	165	22
559	508	7	11	64	32	279	29
610	102	6	9	40	17	102	16
610	203	6	9	40	17	140	19

6.5 Pulley diameters

In designing belt drives, it should be recognized that the use of larger pulley diameters will result in lower bearing loads and can result in the use of smaller and less expensive belt cross-sections. The largest possible pulley allowed by space limitations should be used so as to reduce required effective belt pull or friction force. Pulley diameters for rubber belts should conform to Table 2. Table 7 also specifies the minimum and recommendable pulleys diameters for nylon cord belts.

6.6 Markings

6.6.1 The following information shall be engraved or embossed on the pulley:

- 1) Classification of pulley
- 2) Diameter and width of the pulley
- 3) Manufacturer’s name and/or its trademark

6.6.2 The following information shall be marked on the packaging:

- 1) Classification of pulley
- 2) Diameter and width of the pulley
- 3) Manufacturer’s name, trademark, and address

7 Recommended Design Practices

7.1 Belt selection

7.1.1 The type of rubber belt to be used and the number of ply can be determined by using Table 2 given the belt speed and the pulley diameter.

7.1.2 The appropriate cross section to be used for nylon cord belts can be determined by using the belt selection chart presented in Figure 2.

7.2 Length calculations

7.2.1 The approximate belt length for an open two-pulley drive (Figure 3) may be calculated using the formula

$$L = 2C + \frac{\pi}{2}(D_L + D_S) + \frac{(D_L - D_S)^2}{4C} \dots\dots\dots[\text{Eq. 1}]$$

Where:

- L = length of the belt (mm)
- C = distance between centers of pulleys (mm)
- D_L = diameter of the large pulley (mm)
- D_S = diameter of the small pulley (mm)

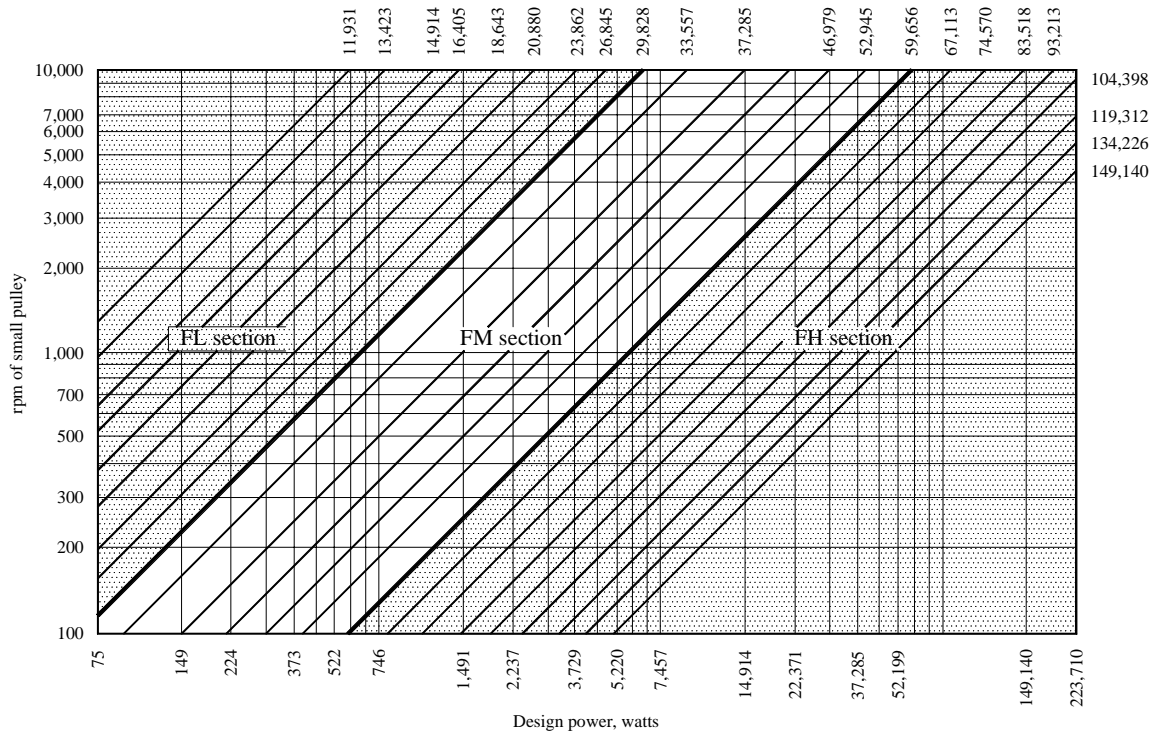

Figure 2 – Flat cord belt selection chart

7.2.2 For endless belts, if this calculation results in a length that is not of standard length, the next longer standard length should be used and necessary correction for center distance should be made. The center distance can be calculated from the formula:

$$C = \frac{b + \sqrt{b^2 - 32(D_L - D_S)^2}}{16} \dots\dots\dots[\text{Eq. 2}]$$

Where:

$$b = 4L_s - 6.28(D_L + D_S)$$

L_s = available belt standard length

7.2.3 For crossed belts (Figure 4), the approximate belt length may be calculated using the formula

$$L = 2C + \frac{\pi}{2}(D_L + D_S) + \frac{(D_L + D_S)^2}{4C} \dots\dots\dots[\text{Eq. 3}]$$

Where

- L = length of the belt (mm)
- C = distance between centers of pulleys (mm)
- D_L = diameter of the large pulley (mm)
- D_S = diameter of the small pulley (mm)

7.2.3 To determine the belt length when more than two pulleys are used on a drive (Figure 5), lay out the pulleys in terms of their effective diameters to scale in the position desired when a new belt is applied and first brought to driving tension. The length of the belt shall be the sum of the tangents and the connecting arcs around the effective diameters of the pulleys. The length of the connecting arcs can be calculated by the formula

$$\text{Length of arc} = \frac{D \times A}{115} \dots\dots\dots[\text{Eq. 4}]$$

Where

- D* = the diameter of the pulley
- A* = the angle in degrees subtended by the arc of belt contact on the pulley

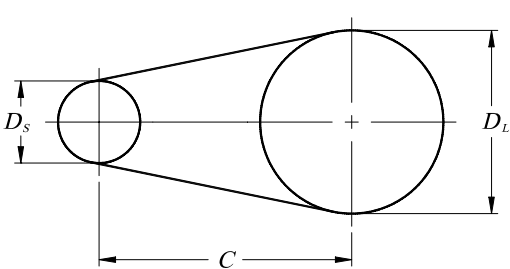

Fig. 3 – Flat belt drive with two pulleys

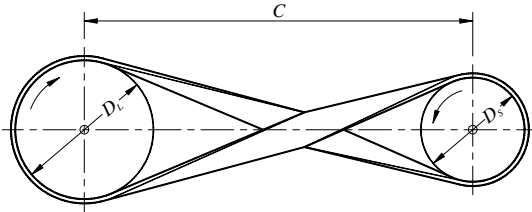

Fig. 4 – Crossed belt

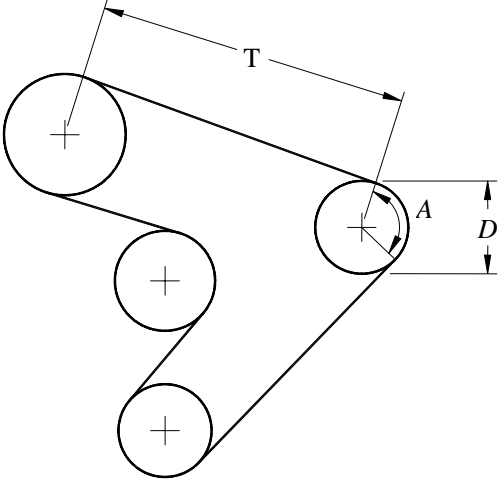

Fig 5 – Flat belt drive with more than two pulleys

7.3 Correction for arc of contact

Correction for arc of contact for small pulley is determined from Table 11, the arc of contact being given by the approximate formula:

$$Arc\ of\ contact = 180 - \frac{60(D_L - D_S)}{C} \dots\dots\dots [Eq.5]$$

Where:

- D_L = diameter of the large pulley
- D_S = diameter of the small pulley
- C = center distance of drive.

7.4 Power rating

The power rating for rubber belts are given in Table 1. Power ratings for nylon cord belts are given in Tables 4-6. The width of belts in millimeters can be calculated by the formula:

$$W = \frac{H \times S}{K \times C} \dots\dots\dots [Eq. 6]$$

Where

- W = belt width in millimeters
- H = actual power transmitted, or if not, the nameplate power rating
- S = service factor from Table 12
- K = power rating of belt in watts per millimeter of belt width from Table 1
- C = arc of contact factor from Table 11

Table 11 – Arc of contact factor for C

Arc of contact*, deg	Factor, C	Arc of contact*, deg	Factor, C
180	1.00	132	0.87
174	0.99	126	0.85
168	0.97	120	0.83
162	0.96	114	0.80
156	0.94	108	0.78
150	0.92	102	0.75
144	0.90	96	0.72
138	0.88	90	0.69

* For small pulley

Table 12 – Service factors, S

Application	Squirrel –cage ac motor		Wound rotor a-c motor (slip ring)	Single- phase capacity motor	d-c shunt- wound motor	Diesel engine, 4 or more cyl, above 700 rpm
	Normal torque, line start	High torque				
Agitators	1.0-1.2	1.2-1.4	1.2	-	-	-
Compressors	1.2-1.4	-	1.4	1.2	1.2	1.2
Belt conveyors	-	1.4	-	-	1.2	-
Screw conveyors	-	1.8	-	-	1.6	-
Crushing machinery	-	1.6	1.4	-	-	1.4-1.6
Fans, centrifugal	1.2	-	1.4	-	1.4	1.4
Fans, propeller	1.4	2.0	1.6	-	1.6	1.6
Generators and exciters	1.2	-	-	-	1.2	2.0
Line shafts	1.4	-	1.4	1.4	1.4	1.6
Machine tools	1.0-1.2	-	1.2-1.4	1.0	1.0-1.2	-
Pumps, centrifugal	1.2	1.4	1.4	1.2	1.2	-
Pumps, reciprocating	1.2-1.4	-	1.4-1.6	-	-	1.8-2.0

8 Connectors

Table 13 specifies the sizes of plate and diameter of bolt for belts using bolted plate fastener.

Table 13 – Plate size based on belt width

Size of plate	Belt width, mm	Diameter of bolt, mm
0	38-51	6
1 small	64-102	6
1 large	127-152	7
2 small	178	8
3 small	254-406	10
3 large	432-508	10
4	533-610	11
5	Above 610	13

9 Safety

9.1 Enclosing the drive with covers is recommended for safety and to avoid foreign materials from getting in contact with the drive.

9.2 Make drive inspection on a periodic basis. Drives should be inspected for the tightness of the belts, keys and setscrews. Condition of the belt should also be inspected.

9.3 Use belts with proper markings.

9.4 Use proper keys as specified in PAES 304:2000

Annex A
(Informative)

Example of flat rubber belt drive selection

A.1 Given parameters

Assume a normal-torque squirrel-cage ac motor for a centrifugal-fan drive. The motor speed is 1,725 rpm and the pulley diameter is 127 mm. The power transmitted at the given rpm is 2,983 W. The arc of contact is 160°. Select the appropriate flat belt and the corresponding pulley to be used.

A.2 Belt speed

The belt speed is approximated as:

$$V = \frac{\pi \times D_s \times n_s}{1,000}$$

Where:

V is the belt speed

D_s is the diameter of the small pulley

N_s is the rpm of the small pulley

$$V = \frac{\pi \times D_s \times n_s}{1,000} = \frac{\pi \times 127 \text{ mm} \times 1,725 \text{ rpm}}{1,000} = 688.24 \text{ m/min}$$

A.3 Belt selection

A.3.1 The appropriate belt for the given pulley diameter and the approximated belt speed is a 3 ply, Fabric belt (from Table 2).

A.3.2 The power rating for a 3 ply, fabric belt, and at the computed belt speed is obtained from Table 1. The value is obtained by interpolating values of K between 79 and 97 m/min. This will result in a K value equal to 88.26 watts/mm.

A.3.3 The arc correction factor, C , is equal to 0.93 (from Table 11) and the service factor, S , is equal to 1.2 (from Table 12).

A.3.4 The width of the belt is computed as:

$$W = \frac{H \times S}{K \times C} = \frac{(2,983 \text{ W} \times 1.2)}{(88.26 \text{ W/mm} \times 0.93)} = 43.61 \text{ mm}$$

Therefore, use a 44 mm width belt.

A.4 Pulley width

Using Table 9, the width of pulley to be used is computed as:

$$B = \text{belt width} + \text{allowance} = 44 \text{ mm} + 25 \text{ mm} = 69 \text{ mm}$$