PHILIPPINE AGRICULTURAL ENGINEERING STANDARD PAES 010-2: 2005
General - Formulation of PAES – Part 2 : Rules for the Structure and Drafting

Foreword

The formulation of this national standard was initiated by the Agricultural Machinery Testing and Evaluation Center (AMTEC) and Department of Agriculture.

This standard is the second part in the Formulation of Philippine Agricultural Engineering Standards (PAES) which was developed as a guide to those involved in standards work in the field of Agricultural Engineering.

This standard was adopted from PNS 01-4: 1998 (ISO-IEC Directives Part 3: 1997) – Rules for the Structure and Drafting of International Standards. However, parts from the original standard which are not relevant in the formulation of PAES were either discarded or modified.

This standard provides guidelines for the structure and drafting of Philippine Agricultural Engineering Standards.

General - Formulation of PAES – Part 2 : Rules for the Structure and Drafting

1 Scope

This standard specifies rules for the structure and drafting of Philippine Agricultural Engineering Standards (PAES). This also gives some indication with regard to presentation.

2 References

The following normative documents contain provisions, which, through reference in this text, constitute provisions of this National Standard:

ISO 31 (all parts), *Quantities and units*

ISO 690, *Documentation – Bibliographic references – Content, form and structure*

ISO 1000, *SI units and recommendations for the use of their multiples and certain other units*

ISO 3098-1, *Technical drawings – Lettering – Part 1: Currently used characters*

ISO 7000, *Graphical symbols for use on equipment – Index and synopsis*

3 Definitions

For the purpose of this standard, the following definitions shall apply:

**3.1
standard**

document, established by consensus and approved by a recognized body, that provides, for common and repeated use, rules, guidelines or characteristics for activities or their results, aimed at the achievement of the optimum degree of order in a given context

NOTE Standards should be based on the consolidated results of science, technology and experience, and aimed at the promotion of optimum community benefits.

**3.2
normative elements**

those elements setting out the provisions to which it is necessary to conform in order to be able to claim compliance with the standard

3.3 Informative elements

3.3.1

preliminary elements

those elements that identify the standard, introduce its content and explain its background, its development and its relationship with other standards

3.3.2

supplementary elements

those elements that provide additional information intended to assist the understanding or use of the standard

3.4

required element

element the presence of which in a standard is obligatory

3.5

optional element

element the presence of which in a standard is dependent on the provisions of the particular standard

3.6

provision

expression in the content of a normative document, that takes the form of a statement, an instruction, a recommendation or a requirement

NOTE These types of provision are distinguished by the form of wording they employ: e.g. instructions are expressed in the imperative mode, recommendations by the use of the auxiliary “should” and requirements by the use of the auxiliary “shall”.

3.6.1

statement

provision that conveys information

3.6.2

instruction

provision that conveys an action to be performed

3.6.3

recommendation

provision that conveys advice or guidance

3.6.4

requirement

provision that conveys criteria to be fulfilled

4 Structure

4.1 Subdivision of the subject matter

4.1.1 General

Standards are so diverse that no universally acceptable rules can be established for the subdivision of the subject matter.

However, as a general rule, an individual standard shall be prepared for each subject to be standardized, and published as a complete entity. In specific cases and for practical reasons for example

- the standard is likely to become voluminous.
- subsequent portions of the content are interlinked.
- portions of the standard could be referred to in regulations, or
- portions of the standard are intended to serve for certification purposes,

the standard may be split into separate parts under the same number. This has the advantage that each part can be changed separately when the need arises.

In particular, the aspects of a product which will be of separate interest to different parties (e.g. manufacturers, certification bodies, legislative bodies) shall be clearly distinguished, preferably as parts of a standard or a separate standard.

Such individual aspects are, for example,

- health and safety requirements,
- performance requirements,
- maintenance and service requirements,
- installation rules, and
- quality assessment

The terms which shall be used to designate the divisions and subdivisions that a standard may have are shown in Table 1. For an example of numbering see Annex A.

Table 1 – Names of divisions and subdivisions

| Term | Example of Numbering |
|-----------|----------------------|
| part | 9999-1 |
| clause | 1 |
| subclause | 1.1 |
| subclause | 1.1.1 |
| paragraph | [no number] |
| annex | A |

4.1.2 Subdivision of the subject matter within a series of parts

There are two systems in use for subdividing into parts.

- a) Each part deals with a specific aspect of the subject and can stand alone.

EXAMPLE 1

Part 1: Definitions

Part 2: Requirements

Part 3: Test methods

Part 4: ...

- b) There are both common and specific aspects to the subject. The common aspects shall be given in Part 1. Specific aspects (which may modify or supplement the common aspects and therefore cannot stand alone) shall be given in individual parts.

EXAMPLE 2

Part 1: General requirements

Part 2.1: Particular requirements for electric irons

Part 2.2: Particular requirements for spin extractors

Part 2.3: Particular requirements for dishwashers

Where the system described in b) is used, care shall be taken that the references from one part to another are always to the latest edition. There are two ways to achieve this.

- If reference is made to a particular element, the reference shall be dated (see 5.6.6.5.2).

- Since the complete series of parts is normally under the control of the same technical committee (TC), the use of undated references (see 5.6.6.5.3) is permitted, provided that corresponding changes are implemented simultaneously in all parts.

The use of undated references requires a high degree of discipline by the TC responsible for the standard.

Their use is not permitted between standards of different TCs except where the normative reference is intentionally undated, i. e., it is accepted that it will be possible to use in all future changes of the text referred to for the purposes of the referring standard.

Each part of a multipart standard shall be drafted in accordance with the rules for an individual standard.

4.1.3 Subdivision of the subject matter within an individual standard

The elements that together form a standard may be classified in two different ways:

- a) by their normative/informative nature and their position within the structure, i.e.
 - informative preliminary elements (see 3.3.1),
 - normative general and technical elements (see 3.2), and
 - informative supplementary elements (see 3.3.2);
- b) by their required or optional presence (see 3.4 and 3.5)

An example of a typical arrangement is given in Table 2 which lists the permitted content of each of the elements constituting the arrangement.

Table 2 – Example of a typical arrangement of elements in a standard

| | Arrangement of elements ^a in standard | Permitted content ^a of element(s) in a standard |
|-------------------------|--|--|
| Informative preliminary | <i>Title page</i> | Title |
| | <i>Table of contents</i> | <i>(generated content, see 5.1.2)</i> |
| | Foreword | Text <i>Note(s)</i> <i>Footnote(s)</i> |
| | <i>Introduction</i> | <i>Text</i> <i>Figure(s)</i> <i>Table(s)</i> <i>Note(s)</i> <i>Footnote(s)</i> |

| | Title | Text |
|---|--|--|
| Normative general | Scope | Text Figure(s) Table(s) Note(s) Footnote(s) |
| | Normative reference(s) | Reference(s) Footnote(s) |
| | Term(s) and definition(s) Symbols and abbreviated terms Requirements : Normative annex | Text Figure(s) Table(s) Note(s) Footnote(s) |
| Informative supplementary | <i>Informative annex^b</i> | Text Figure(s) Table(s) Note(s) Footnote(s) |
| Normative technical | Normative annex | Text Figure(s) Table(s) Note(s) Footnote(s) |
| Informative supplementary | Bigliography | Reference(s) Footnote(s) |
| | Index(es) | (generated content; see 5.4.3) |
| ^a Bold type = required element; upright type = normative element; italic type = informative element ^b Informative annexes may not contain normative elements unless these elements constitute optional provisions. For example, a test method that is optional may contain provisions. | | |

A standard need not contain all the normative technical elements shown and it may contain normative technical elements other than those shown. Both the nature of the normative technical elements and their sequence are determined by the nature of the standard in question.

A standard may also contain notes and footnotes to figures and tables (see 5.6.4.7, 5.6.4.8, 5.6.5.6 and 5.6.5.7).

Terminology standards have different requirements for the subdivision of content (see annex B).

4.2 Description and numbering of divisions and subdivisions

4.2.1 Part

The number of a part shall be indicated by Arabic numerals, beginning with 1, following the standard number and preceded by a hyphen, for example,

9999-1, 9999-2, etc.

The title of a part shall be composed in the same way as that of a standard as described in 5.1.1. All individual titles in a series of parts shall contain the same introductory element (if present) and main element, while the complementary element shall be different in each case in order to distinguish the parts from one another. The complementary element shall be preceded in each case by the designation “Part”.

If a standard is published in the form of a number of separate parts, the first part shall include in its foreword (see 5.1.3) an explanation on the intended structure. In the foreword of each part belonging to the series, a reference shall be made to the titles of all other parts, if they are known.

4.2.2 Clause

A clause is the basic component in the subdivision of the content of a standard.

The clauses in each standard or part shall be numbered with arabic numerals, beginning with 1 for the “Scope” clause. The numbering shall be continuous up to but excluding any annexes (see 4.2.6)

Each clause shall have a title, placed immediately after its number, on a line separate from the text that follows it.

4.2.3 Subclause

A subclause is a numbered subdivision of a clause. A primary subclause (e.g. 4.1, 4.2, etc.) may be subdivided into secondary subclauses (e.g. 4.1.1, 4.1.2, etc), and this process of subdivision may be continued as far as the fifth level (e.g. 4.1.1.1.1.1, 4.1.1.1.1.2, etc).

Subclauses shall be numbered with arabic numerals (see annex A for an example).

A subclause shall not be created unless there is at least one further subclause at the same level. For example, a piece of text in clause 10 shall not be designated subclause “10.1” unless there is also a subclause “10.2”.

Each primary subclause should preferably be given a title, which shall be placed immediately after its number, on a line separate from the text that follows it. Secondary subclauses may be treated in the same way. Within a clause or subclause, the use of titles shall be uniform for subclauses at the same level, e.g. if 10.1 has a title, 10.2 shall also have a title. In the absence of titles, key terms or phrases (composed in distinctive type) appearing at the beginning of the text of the subclause may be used to call attention to the subject matter dealt with. Such terms or phrases will not be listed in the table of contents.

4.2.4 Paragraph

A paragraph is an unnumbered subdivision of a clause or subclause.

“Hanging paragraphs” such as those shown in the following example shall be avoided since reference to them is ambiguous.

EXAMPLE In the following example, the hanging paragraphs indicated cannot be uniquely identified as being in “clause 5” since strictly speaking the paragraphs in 5.1 and 5.2 are also in clause 5. To avoid this problem it would be necessary either to identify the unnumbered paragraph as subclause “5.1 XXXXXXXXXXXXX” and to renumber the existing 5.1 and 5.2 accordingly (as shown), or to move the hanging paragraphs elsewhere.

| Correct | Incorrect |
|--|--|
| <p>5 Designation</p> <p>5.1 XXXXXXXXXXXXX</p> <p>XXXXXXXX X XXXXXXXXXXXXX XXXXXXXXXXXXXXXX</p> <p>XXXXXXXX X XXXXXXXXXXXXX XXXXXXXXXXXXXXXX</p> <p>XXXXXXXX X XXXXXXXXXXXXX XXXXXXXXXXXXXXXX</p> <p>5.2 XXXXXXXXXXXXX</p> <p>XXXXXXXX X XXXXXXXXXXXXX XXXXXXXXXXXXXXXX</p> <p>5.3 XXXXXXXXXXXXX</p> <p>XXXXXXXX X XXXXXXXXXXXXX XXXXXXXXXXXXXXXX</p> <p>XXXXXXXX X XXXXXXXXXXXXX XXXXXXXXXXXXXXXX XXXXXXXXXXXXXXXX XXXXXXXXXXXXXXXX XXXXXXXXXXXXXXXX XXXXXXXXXXXXXXXX XXXXXXXXXXXXXXXX XXXXXXXXXXXXX</p> <p>6 Test report</p> | <p>5 Designation</p> <p>XXXXXXXX X XXXXXXXXXXXXX XXXXXXXX X XXXXXXXXXXXXX XXXXXXXX X XXXXXXXXXXXXX</p> <p>} hanging paragraphs</p> <p>5.1 XXXXXXXXXXXXX</p> <p>XXXXXXXX X XXXXXXXXXXXXX XXXXXXXXXXXXX</p> <p>5.2 XXXXXXXXXXXXX</p> <p>XXXXXXXX X XXXXXXXXXXXXX XXXXXXXXXXXXX XXXXXXXXXXXXXXXX XXXXXXXXXXXXX XXXXXXXX XXXXXXXXXXXXXXXX XXXXXXXXXXXXX XXXXXXXXXXXXXXXX XXXXXXXXXXXXXXXX XXXXXXXXXXXXX</p> <p>6 Test report</p> |

4.2.5 Lists

Lists may be introduced by a sentence (see example 1), a complete grammatical proposition followed by a colon (see example 2), or by the first part of a proposition (without a colon – see example 3), completed by the items in the list.

Each item in a list shall be preceded by a dash or a bullet or, if necessary for identification, by a lower-case letter followed by a parenthesis. If it is necessary to subdivide further an item in latter type of list, arabic numerals followed by a parenthesis shall be used (see example 1).

EXAMPLE 1 The following basic principles shall apply to the drafting of definitions.

- a) The definition shall have the same grammatical form as the term:
 - 1) to define a verb, a verbal phrase shall be used;
 - 2) to define a singular noun, the singular shall be used.
- b) The **preferred structure** of a definition is a basic part stating the class to which the concept belongs, and another part enumerating the characteristics that distinguish the concept from other members of the class.
- c) The **definition of a quantity** shall be formulated in accordance with the provisions of ISO 31-0:1992, 2.2. This means that a derived quantity may be defined by means of other quantities only. No unit shall be used in the definition of a quantity.

EXAMPLE 2 No switch is required for any of the following categories of apparatus:

- apparatus having a power consumption not exceeding 10W under normal operating conditions;
- apparatus having a power consumption not exceeding 50W, measured 2 min after the application of any of the fault conditions;
- apparatus intended for continuous operation.

EXAMPLE 3 Vibrations in the apparatus may be caused by

- Unbalance in the rotating elements,
- slight deformations in the frame,
- the rolling bearings, and
- aerodynamic loads.

Key terms or phrases may be composed in distinctive type to call attention to the subject matter dealt with in the various list items (see example 1). Such terms or phrases will not be listed in the table of contents; it is a requirement that they are listed, they shall not be presented as list items but as subclause titles (see 4.2.3).

4.2.6 Annex

For the description of the two types of annex, see 5.3.8 and 5.4.1

Annexes shall appear in the order in which they are cited in the text. Each annex shall be designated by a heading comprising the word “Annex” followed by a capital letter designating its

serial order, beginning with “A”, e.g. “Annex A”. The annex heading shall be followed by the indication “(normative)” or “(informative)”, and by the title, each on a separate line. Numbers given to the clauses, subclauses, tables, figures and mathematical formulae of an annex shall be preceded by the letter designating that annex followed by a full-stop. The numbering shall start afresh with each annex. A single annex shall be designated “Annex A”.

EXAMPLE Clauses in annex A are designated “A.1”, “A.2”, “A.3”, etc.

4.2.7 Bibliography

A bibliography, if present, shall appear after the last annex. For the drafting rules, see 5.4.2.

4.2.8 Index(es)

Index(es), if present, shall appear as the last element. For the drafting rules, see 5.4.3.

5 Drafting

5.1 Preliminary informative elements

5.1.1 Title page

The title page shall contain the title of the standard.

The wording of the title shall be established with the greatest care; while being as concise as possible, it shall include, without ambiguity, the subject matter of the standard in such a way as to distinguish it from that of other standards, without going into unnecessary detail. Any necessary additional particulars shall be given in the scope.

The title shall be composed of separate elements, each as short as possible, proceeding from the general to the particular. In general, not more than the following three elements shall be used:

- a) an *introductory element* (optional) indicating the general field to which the standard belongs (this can often be based on the title of the committee).
- b) a *main element* (obligatory) indicating the principal subject treated within that general field;
- c) a *complementary element* (optional) indicating the particular aspect of the principal subject or giving details that distinguish the standard from other standards, or other parts of the same standard.

Detailed rules for the drafting of titles are given in annex C.

5.1.2 Table of contents

The table of contents is an optional preliminary element, but is necessary if it makes the standard easier to consult. The table of contents shall be entitled “Contents” and shall list clauses and, if appropriate, subclauses with titles, annexes together with their status in parentheses, the bibliography, index(es), figures and tables. The order shall be as follows: clauses and subclauses with titles; annexes (including clauses and subclauses with titles is appropriate); the bibliography; index(es); figures; tables. All the elements listed shall be cited with their full titles. Terms in the “Terms and definitions” clause shall not be listed in the table of contents.

In electronic documents, the table of contents shall be generated automatically and not set manually.

5.1.3 Foreword

The foreword shall appear in each standard. It shall not contain requirements, figures or tables.

It consists of a general part giving information relating to the organization responsible in general, i.e.

- the designation and name of the committee that prepared the standard, and
- information regarding the approval of the standard,

and a specific part that shall give as many of the following as are appropriate:

- an indication of any other organization that has contributed to the preparation of the standard;
- a statement that the standard cancels and replaces other documents in whole or in part;
- a statement of significant technical changes from the previous edition of the standard;
- the relationship of the standard to other standards or other documents;
- a statement specifying which annexes are normative and which are informative.

5.1.4 Introduction

The introduction is optional preliminary element used, if required, to give specific information of commentary about the technical content of the standard, and about the reasons prompting its preparation. It shall not contain requirements.

The introduction shall not be numbered unless there is a need to create numbered subdivisions. In this case, it shall be numbered 0 with subclauses being numbered 0.1, 0.2, etc. Any numbered figure, table, displayed formula or footnote shall be numbered normally beginning with 1.

5.2 General normative elements

5.2.1 Scope

This element shall appear at the beginning of each standard and define without ambiguity the subject of the standard and the aspect(s) covered, thereby indicating the limits of applicability of the standard or particular parts of it. It shall contain requirements.

The scope shall be succinct so that it can be used as a summary for bibliographic purposes.

This element shall be worded as a series of statements of fact. Forms of expression such as the following shall be used:

“This National Standard

- specifies {
 - the dimensions of ...”
 - a method of ...”
 - the characteristics of ...”
- establishes {
 - a system for ...”
 - general principles for ...”
- gives guidelines for ...”
- defines terms ...”

Statements of applicability of the standard shall be introduced by the following wording:

“This National Standard is applicable to ...”

5.2.2 Normative references

This optional element shall give a list of the normative documents to which reference is made (see 5.6.6.5) in the standard in such a way as to make them indispensable for the application of the standard. For dated references, each shall be given with its year of publication, or, in the case of enquiry or final drafts, with a dash together with footnote “To be published.”, and full title. The year of publication or dash shall not be given for undated references. When an undated reference is to all parts of a standard, the publication number shall be followed by the indication “(all parts)” and the general title of the series of parts (i.e. the introductory and main elements, see annex C).

The list shall be introduced by the following wording:

“The following normative documents contain provisions which, through reference in this text, constitute provisions of this National Standard. For dated references, subsequent amendments to, or revisions of any of these publications do not apply. However, parties to agreements based on this National Standard are encouraged to investigate the possibility of applying the most recent editions of the normative documents indicated below. For undated references, the latest edition of the normative document referred to applies.”

The list shall not include the following:

- documents that are not publicly available;
- documents to which only informative reference is made;
- documents which have merely served as references in the preparation of the standard.

Such documents may be listed in a bibliography (see 5.4.2)

5.3 Technical normative elements

5.3.1 Terms and definitions

This is an optional element giving definitions necessary for the understanding of certain terms used in the standard. The following introductory wording, modified as appropriate, shall be used:

“For the purposes of this National Standard, the terms and definitions given in ...and the following apply”

Rules for the drafting and presentation of terms and definitions are given in annex B, together with special rules for terminology standards, such as vocabularies, nomenclatures or lists of equivalent terms in different languages.

5.3.2 Symbols and abbreviated terms

This is an optional element giving a list of the symbols and abbreviated terms necessary for the understanding of the standard.

Unless there is a need to list symbols in a specific order to reflect technical criteria, all symbols should be listed in alphabetical order in the following sequence:

- upper case Latin letter followed by lower case Latin letter (*A, a, B, b*. etc.);
- letters without indices preceding letters with indices, and with letter indices preceding numerical ones (*B, b, C, C_m, C₂, c, d, d_{ext}, d_{int}, d_l*, etc.);
- Greek letters following Latin letters (*Z, z, A, a, B, β...A, λ*, etc.);
- any other special symbol.

For convenience, this element may be combined with element 5.3.1 in order to bring together terms and their definitions, symbols, abbreviated terms and perhaps units under an appropriate composite title, example “Terms, definitions, symbols, units and abbreviated terms”.

5.3.3 Requirements

This element is optional. If present, it shall contain the following:

- a) all characteristics relevant to the aspect(s) of the product(s), process(es) or service(s) covered in the standard, either explicitly or by reference;
- b) the required limiting values of quantifiable characteristics;
- c) for each requirement, either a reference to the test method for determining or verifying the value or the characteristic, or the test method itself (see 5.3.5)

A clear distinction shall be made between requirements, statements and recommendations.

Contractual requirements concerning claims, guarantees, covering of expenses, etc. shall not be included.

In some product standards, it may be necessary to specify that the product shall be accompanied by warning notices or by instructions to the user or installer, and to specify their nature. On the other hand, requirements concerning use of installation as such shall be included in a separate part or a separate standard since they are not requirements applicable to the product itself.

Standards listing characteristics for which suppliers are required to state values that are not specified in the standard itself shall specify how such values are to be measured and stated

5.3.4 Sampling

This optional element specifies the conditions and methods of sampling, as well as the method for the preservation of the sample(s). This element may appear at the beginning of element 5.3.5.

5.3.5 Test methods

This optional element gives all the instructions concerning the procedure for determining the values of characteristics, or for checking conformity to stated requirements, and for ensuring the reproducibility of the results. If appropriate, tests shall be identified to indicate whether they are type tests, routine tests, sampling tests and so on.

Instructions relating to test methods may be subdivided in the following order (where appropriate):

- a) principle;
- b) reagents or materials;
- c) apparatus;
- d) preparation and preservation of test samples and test pieces;
- e) procedure;
- f) expression of results, including method of calculation and precision of the test method;

g) test report.

Test methods may be presented as separate clauses, or be incorporated in element 5.3.3, or be presented as annexes (see 5.3.8) or as separate parts (see 4.2.1). A test method shall be prepared as separate standard if it is likely to be referred to in a number of other standards.

5.3.6 Classification and designation

This optional element may establish a system of classification, designation and/or coding of products, processes or services that conform to stated requirements. For convenience, the element may be combined with element 5.3.3.

5.3.7 Marking, labeling and packaging

This optional element may specify the marking of a product (e.g. manufacturer's or vendor's trade mark, model or type number). It may include requirements for the labeling and/or packaging of the product (e.g. handling instructions, hazard warnings, and date of manufacture).

Symbols specified for the marking shall be in conformity with relevant International Standards.

Element 5.3.6 and 5.3.7 may be supplemented by an informative annex giving an example of ordering information.

5.3.8 Normative annexes

Normative annexes are integral parts of the standard. Their presence is optional. An annex's normative status (as opposed to informative – (see 5.4.1) shall be made clear by the way in which it is referred to in the text, by a statement to this effect in the foreword (see 5.1.3) and by an indication in the table of contents and under the heading of the annex,

5.4 Supplementary informative elements

5.4.1 Informative annexes

Informative annexes give additional information intended to assist the understanding or use of the standard and shall not contain provisions to which it is necessary to conform in order to be able to claim compliance with the standard. Their presence is optional. An annex's informative status (as opposed to normative – see 5.3.8) shall be made clear by the way in which it is referred to in the text, by a statement to this effect in the foreword (see 5.1.3) and by an indication in the table of contents and under the heading of the annex.

5.4.2 Bibliography

The relevant rules set out in ISO 690 shall be followed.

5.4.3 Index(es)

Authors of non-terminology standards wanting to introduce indexes are ...

5.5 Other informative elements

5.5.1 Notes and examples integrated in the text

Notes and examples integrated in the text of a standard shall only be used for giving additional information intended to assist the understanding or use of the standard and shall not contain provisions to which it is necessary to conform in order to be able to claim compliance with the standard.

Notes and examples should preferably be placed at the end of the clause or subclause, or after the paragraph, to which they refer.

A single note in a clause or subclause shall be preceded by “NOTE”, placed at the beginning of the first line of the text of the note. When several notes occur within the same clause or subclause, they shall be designated “NOTE 1”, “NOTE 2”, “NOTE 3”, etc.

A single example in a clause or subclause shall be preceded by “EXAMPLE”, placed at the beginning of the first line of the text of the example. When several examples occur within the same clause or subclause, they shall be designated “EXAMPLE 1”, “EXAMPLE 2”, “EXAMPLE 3”, etc.

In drafts, all lines of a note or example shall be inset from the margin or shall be set in smaller type, so that its extent can be determined.

5.5.2 Footnotes to the text

Footnotes to the text give additional information, their use shall be kept to a minimum. They shall not contain requirements. Footnotes to figures and tables follow different rules (see 5.6.4.8 and 5.6.5.7).

Footnotes to the text shall be placed at the foot of the relevant page and be separated from the text by a short thin horizontal line on the left of the page.

Footnotes to the text shall normally be distinguished by Arabic numerals, beginning with 1, followed by one parenthesis and forming a continuous numerical sequence throughout the document: 1), 2), 3), etc. The footnotes shall be referred to in the text by inserting the same numerals, as superscripts, after the word or sentence in question: ^{1) 2) 3)} etc.

In certain cases, for example in order to avoid confusion with superscript numbers, one or more asterisks or other appropriate symbols may be used instead: *, **, ***, etc.; †, ‡, etc.

5.6 Common rules and elements

5.6.1 Verbal forms for the expression of provisions

5.6.1.1 A standard does not in itself impose any obligation upon anyone to follow it. However, such an obligation may be imposed, for example, by legislation or by a contract. In order to be able to claim compliance with a standard, the user needs to be able to identify the requirements he

is obliged to satisfy. He needs also to be able to distinguish these requirements from other provisions where he has a certain freedom of choice.

5.6.1.2 Clear rules for the use of verbal forms (including modal auxiliaries) are therefore essential.

5.6.1.3 Annex D gives, in the first column of each table., the verbal form that shall be used to express each kind of provision. The equivalent expressions given in the second column shall be used only in exceptional cases when the form given in the first column cannot be used for linguistic reasons.

5.6.2 Spelling and abbreviation of names organizations, and style

The spelling of the names of organizations and their abbreviations, shall be as used by those organizations.

To facilitate understanding by all readers, the style shall be as simple and concise as possible.

Abbreviated terms shall be used with care, and their use shall be limited to those cases where it is not likely to cause confusion.

If a list of abbreviated terms is not given in the standard (see 5.3.2), then the first time that an abbreviated term is used, the full term shall be given with the abbreviated term following in parentheses.

An abbreviated term shall be specified only if used subsequently in the standard.

The general rule is that abbreviated terms consisting of the initial letters of words be printed in lower-case letters (for example, “a.c.” for “alternating current”) and a full-stop be placed after each letter. Where, however, an abbreviated term comprises capital letters, no full-stops are required.

When a sentence begins with an abbreviated term consisting of several letters, all the letters of the abbreviated term shall be capital letters.

5.6.3 Use of trade names

A correct designation or description of a product shall be given rather than a trade name (brand name).

Proprietary trade names (i.e. trade marks) for a particular product should as far as possible be avoided, even if they are in common use.

If, exceptionally, trade names cannot be avoided, their nature shall be indicated, e.g. by the symbol ® for a registered trade mark (see example 1).

EXAMPLE 1 Instead of “Teflon®”, write “polytetraflouroethylene (PTFE)”.

If it is known that only one product is currently available that is suitable for the successful application of the standard, the trade name of the product may be given in the text of the standard but shall be associated with a footnote as shown in example 2.

EXAMPLE 2 “1) ...[trade name of product] ... is the trade name of a product supplied by ... [supplier] ... This information is given for the convenience of users of this National Standard and does not constitute an endorsement by ... [Name of Organization] ... of the product named. Equivalent products may be used if they can be shown to lead to the same results.”

If it is considered to be essential to give an example (or examples) of commercially available products suitable for successful application of the standard because the product characteristics are difficult to describe in detail, trade names may be given in a footnote as shown in example 3.

EXAMPLE 3 “1) ... [trade name(s) of product(s)] ... is (are) an example(s) of a suitable product(s) available commercially. This information is given for the convenience of users of this National Standard and does not constitute an endorsement by ... [Name of Organization] ... of this (these) product(s).”

5.6.4 Figures

5.6.4.1 Usage

Figures should be used wherever appropriate to present information in an easily comprehensible form. It shall be possible to refer to each figure explicitly within the text.

One level of subdivision only is permitted [e.g. Figure 1 may be subdivided as a), b), c), etc.].

5.6.4.2 Form

Figures shall be in the form of line drawings. Photographs may be used only if it is not possible to convert them into line drawings.

Correctly prepared drawings, sketches, graphs, etc. may be supplied on transparent film (originals or copies) or as clear black and white photographic reproductions. Photocopies are not usable.

5.6.4.3 Numbering

Figures shall be numbered with Arabic numerals, beginning with 1. This numbering shall be independent of the numbering of the clauses and of any tables. A single figure shall be designated “Figure 1”.

5.6.4.4 Layout of title

The title shall be centered horizontally below the figure and laid out as in the following example:

Figure 1 – Details of apparatus

5.6.4.5 Choice of letter symbols, style of lettering, and labeling

Letter symbols used in figures to represent general cases of angular or linear quantities shall be in accordance with ISO 31-1, subscripts being used where necessary to distinguish between different applications of a given symbol.

For a series of symbols indicating various lengths on a drawing use l_1, l_2, l_3 , etc. and not, for instance, A, B, C , etc. or a, b, c , etc.

Lettering on drawings shall be in accordance with ISO 3098-1. Inclined (italic) letters shall be used for

- symbols for quantities,
- subscripts representing symbols for quantities, and
- symbols representing numbers.

The vertical (upright) style shall be used for all other lettering.

In artwork, it is recommended that labeling be substituted by item references wherever possible.

EXAMPLE

Dimensions in millimetres

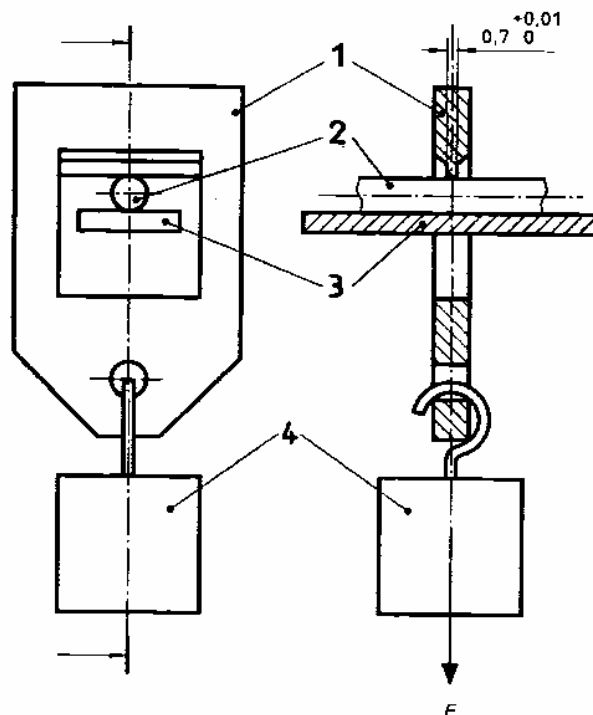

Key

- 1 Test frame**
- 2 Specimen**
- 3 Support**
- 4 Mass**

Figure 1 – Test apparatus for pressure test at high temperature

5.6.4.6 Technical drawings

Technical drawings shall be prepared in accordance with relevant ISO standards.

Graphical symbols for use on equipment shall be in accordance with ISO 7000.

5.6.4.7 Notes to figures

Notes to figures shall be treated independently from notes integrated in the text (see 5.5.1). They shall be located above the title of the relevant figure and shall precede figure footnotes (see the following example). A single note in a figure shall be preceded by “NOTE”, placed at the beginning of the first line of the text of the note. When several notes occur in the same figure, they shall be designated “NOTE 1”, “NOTE 2”, “NOTE 3”, etc. A separate numbering sequence shall be used for each figure.

Notes to figures shall not contain requirements. Any requirements relating to the content of a figure shall be given in the text, in a footnote to the figure or as a paragraph between the figure and its title. It is not necessary that notes to figures are referred to.

EXAMPLE

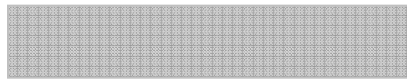

A paragraph containing a requirement

NOTE Figure note

^a Figure footnote

^b Figure footnote

5.6.4.8 Footnote to figures

Footnotes to figures shall be treated independently from footnotes to the text (see 5.5.2). They shall be located immediately above the title of the relevant figure, and shall follow figure notes (see the example in 5.6.4.8).

Footnotes to figures shall be distinguished by superscript lower-case letters, beginning with “a”. The footnotes shall be referred to in the figure by inserting the same superscript lower-case letter.

Footnotes to figures may contain requirement. As a consequence, it is particularly important when drafting the text of the figure footnote to distinguish clearly between different types of provision by using the appropriate verbal forms (see annex D).

5.6.5 Tables

5.6.5.1 Usage

Tables should be used whenever appropriate to present information in an easily comprehensible form. It shall be possible to refer to each table explicitly within the text.

A table within a table is not permitted. Subdivision of a table into subsidiary tables is not permitted.

5.6.5.2 Numbering

Tables shall be numbered with arabic numerals, beginning with 1. This numbering shall be independent of the numbering of the clauses and of any figures. A single table shall be designated “Table 1”.

For the numbering of tables in annexes, see 4.2.6.

5.6.5.3 Layout of title

The title shall be centered horizontally above the table and laid out as in the following example:

Table 1 – Mechanical properties

5.6.5.4 Headings

The first word in the heading of each column shall begin with a capital letter. The units used in a given column shall generally be indicated under the column heading. (See also 5.6.9.1, last paragraph.)

EXAMPLE 1

| Type | Linear density Kg/m | Inside diameter mm | Outside diameter mm |
|-------------|-------------------------------|------------------------------|-------------------------------|
| | | | |

EXAMPLE 2

| Dimensions in millimeters | | | |
|---------------------------|---------------|------------------------|-------------------------|
| Type | Length | Inside diameter | Outside diameter |
| | | | |

The presentation shown in example 3 is not permitted and shall be altered as shown in example 4.

EXAMPLE 3

| | | | |
|------------------|----------|----------|----------|
| Type | A | B | C |
| Dimension | | | |
| | | | |

EXAMPLE 4

| | | | |
|------------------|-------------|----------|----------|
| Dimension | Type | | |
| | A | B | C |
| | | | |

5.6.5.5 Continuation of tables

When a table is continued over two or more pages, the number of the table shall be repeated, followed by the title (optional) and by “(continued)”, as in the following example:

Table 1 (continued)

The column headings together with any statement concerning units shall be repeated on all pages after the first.

5.6.5.6 Notes to tables

Notes to tables shall be treated independently from notes integrated in the text (see 5.5.1). They shall be located within the frame of the relevant table and shall precede table footnotes (see the following example). A single note in a table shall be preceded by “NOTE”, placed at the beginning of the first line of the text of the note. When several notes occur in the same table, they shall be designated “NOTE 1”, “NOTE 2”, “NOTE 3”, etc. A separate numbering sequence shall be used for each table.

Notes to tables shall not contain requirements. Any requirements relating to the content of a table shall be given in the text, in a footnote to the table or as a paragraph within the table. It is not necessary that notes to tables are referred to.

EXAMPLE

| Type | Length | Inside diameter | Outside diameter |
|--|---------------|------------------------|-------------------------|
| | l_1^a | d_1 | |
| | l_2 | d_2^b | |
| A paragraph containing a requirement. NOTE 1 Table note. NOTE 2 Table note | | | |
| ^a Table footnote. | | | |
| ^b Table footnote. | | | |

5.6.5.7 Footnotes to tables

Footnotes to tables shall be treated independently from footnotes to the text (see 5.5.2). They shall be located within the frame of the relevant table, and shall follow table notes (see the example in 5.6.5.6).

Footnotes to tables shall be distinguished by superscript lower-case letters, beginning with “a”. The footnotes shall be referred to in the table by inserting the same superscript lower-case letter.

Footnotes to tables may contain requirements. As a consequence, it is particularly important when drafting the text of the table footnote to distinguish clearly between different types of provision by using the appropriate verbal forms (see annex D).

5.6.6 References

5.6.6.1 General

As a general rule, references to particular pieces of text shall be used instead of repetition of the original source material, since such repetition involves the risk of error or inconsistency and increases the length of the document. However, if it is considered necessary to repeat such material, its source shall be identified precisely.

References shall be made in the forms indicated in 5.6.6.2 to 5.6.6.5 and shall not be made to page numbers.

5.6.6.2 References to the standard as a whole in its own text

Generally, the form “this National Standard...”, “this Technical Report...”, or “this Guide...” should be used as appropriate.

However, to avoid possible confusion in the case where a standard is published in separate parts, the following forms may be used:

- “this part of PAES: 238 (reference to a part only).
- “PAES 335” (reference to a whole series of parts).

Such references are understood to include any future amendments and/or technical corrigenda to the standard.

5.6.6.3 References to elements of text

5.6.6.3.1 Use for example, the following forms:

- “in accordance with clause 2”;
- “according to 3.1”
- “as specified in 3.1 B”;

- “details as given in 3.1.1”
- “see annex B”;
- “the requirements given in B.2”;
- “see the note in Table2”;
- “see example in 2 in 6.6.3”.

It is unnecessary to use the term “subclause”.

5.6.6.3.2 If there is a need to refer to an unordered list item in *another* standard, the following formulation shall be used:

“as specified in PAES 111:2000, second list item”.

5.6.6.4 References to tables and figures

Every table and figure included in the standard shall normally be referred to in the text.

Use, for example, the following forms:

- “given in Table 2”;
- “(see Table B.2)”;
- “shown in Figure A.6”;
- “(see Figure 3)”.

5.6.6.5 References to other documents

5.6.6.5.1 General

References to other documents may be dated or undated. All normative references, dated and undated, shall be given in the “Normative references” clause (see 5.2.2).

5.6.6.5.2 Dated references

Except as provided for in 5.6.6.5.3, normative references shall be dated (i.e. to a specific edition, giving the year of publication, or in the case of enquiry or final drafts giving a dash). References to specific divisions or subdivisions, tables and figures of another document shall always be dated. Subsequent amendments to, or revisions of, dated references will need to be incorporated by amendment of the standard referring to them.

NOTE In this context a part is regarded as a separate standard.

Use the following forms:

- "... carry out the tests given in PAES 226:200...";
- "... in accordance with PAES 301: ____, clause 3, ...";
- "... as specified in PAES 401:200, Table 1, ...".

See also 5.6.6.3.2.

5.6.6.5.3 Undated references

Undated references may be made only to a complete document or a part thereof and only in the following cases:

- a) if it is accepted that it will be possible to use all future changes of the document referred to for the purposes of the referring standard;
- b) for informative references.

Undated references shall be understood to include all amendments to and revisions of the quoted publication.

Use the following forms:

- "... as specified in PAES 225 and PAES 331 ...";
- "... see PAES 112..."

5.6.7 Representation of numbers and numerical values

5.6.7.1 If a value less than 1 is written in decimal form, the decimal sign shall be preceded by a zero.

EXAMPLE 0.001

5.6.7.2 For clarity, the symbol x rather than a point shall be used to indicate multiplication of numbers and numerical values.

EXAMPLE Write 1.8×10^{-3} (not $1.8 . 10^{-3}$ or $1.8 \cdot 10^{-3}$)

5.6.7.3 To express numbers of items (as opposed to numerical values of physical quantities), the numerals one to nine shall as a general rule be spelt out in full.

EXAMPLE 1 "Carry out the test on five tubes, each 5 m long."

EXAMPLE 2 "Select a further 15 tubes, each 5 m long."

To express values of physical quantities, arabic numerals followed by the international symbol for the unit (see ISO 31 and ISO 1000) shall be used.

5.6.8 Quantities, units, symbols and signs

The International System of units (SI) as set out in ISO 31 shall be used. Symbols for quantities shall be chosen, whenever possible, from the various parts of ISO 31 and IEC 27. For further guidance on application, see ISO 1000.

The units in which any values are expressed shall be indicated.

The unit symbols for degree, minute and second (for plane angle) shall follow immediately the numerical value; all other unit symbols shall be preceded by a space (See annex E.)

Mathematical signs and symbols shall be in accordance with ISO 31-11.

5.6.9 Mathematical formulae

5.6.9.1 Types of equations

Equations between quantities are preferred to equations between numerical values. Equations shall be expressed in mathematically correct form, the variables being represented by letter symbols the meanings of which are explained in connection with the equations, unless they appear in a “Symbols and abbreviated terms” clause (see 5.3.2) Descriptive terms or names of quantities shall not be arranged in the form of an equation.

The style shown in example 1 shall be followed.

EXAMPLE 1

$$v = \frac{l}{t}$$

where

- v is the speed of a point in uniform motion;
- l is the distance traveled;
- t is the time interval

If, exceptionally, an equation between numerical values is used, the style shown in example 2 shall be followed.

EXAMPLE 2

$$v = 3.6 \times \frac{l}{t}$$

where

- v is the numerical value of the speed, expressed in kilometers per hour (km/h), of a point in uniform motion;
- l is the numerical value of the distance traveled, expressed in meters (m)
- t is the numerical value of the time interval, expressed in seconds (s)

However, the same symbol shall never be used within a standard both for a quantity and for its corresponding numerical value. For example, use of the equation in example 1 and of the equation in example 2 in the same context would imply the $1 = 3.6$ which obviously is not true.

Notation such as

$$\frac{V}{\text{Km/h}}, \frac{l}{\text{m}} \quad \text{and} \quad \frac{t}{\text{s}} \quad \text{or} \quad v/(\text{km/h}), l/\text{m}, \text{ and } t/\text{s}$$

for numerical values are particularly useful on the axes of graphs and in the headings of columns in tables.

5.6.9.2 Presentation

As far as possible, symbols having more than one level of subscript or superscript shall be avoided, as shall any symbols and formulae that would involve printing more than two lines of type.

EXAMPLE 1 $D_{1, \max}$ is preferable to $D_{1_{\max}}$.

EXAMPLE 2 In the text, a / b is preferable to $\frac{a}{b}$

EXAMPLE 3 In a displayed formula, use

$$\frac{\sin [(N + 1) \varphi/2] \sin (N\varphi/2)}{\sin (\varphi / 2)}$$

rather than

$$\frac{\sin \left[\frac{N + 1}{2} \varphi \right] \sin \left(\frac{N}{2} \varphi \right)}{\sin \frac{\varphi}{2}}$$

Further examples of the presentation of mathematical formulae are given in examples 4 and 5.

EXAMPLE 4

$$-\frac{\partial W}{\partial x} + \frac{d}{dr} \frac{\partial W}{\partial x} = Q \left[(-grad v - \frac{\partial A}{\partial t})_x + (v \times rot A)_x \right]$$

where

- W is the dynamic potential;
- x is the x-coordinate;
- t is time;
- \dot{x} is the time derivative of x ;
- Q is the electric charge;
- v is the electric potential;
- \vec{A} is the magnetic vector potential
- \mathbf{v} is the velocity.

EXAMPLE 5

$$\frac{x(t_1)}{x(t_1 + T/2)} = \frac{e^{-\delta t_1} \cos(\omega t_1 + a)}{e^{-\delta(t_1 + T/2)} \cos(\omega t_1 + a + \pi)} = -e^{\delta T/2} = 1.39215$$

where

- x is the x-coordinate;
- t_1 is the time at the first turning point;
- T is the periodic time;
- ω is the angular frequency;
- a is the initial phase;
- δ is the damping coefficient;
- π is the number 3.1415926...

5.6.9.3 Numbering

If it is necessary to number some or all the formulae in a standard in order to facilitate cross-reference, arabic numbers in parentheses shall be used, beginning with 1:

$$x^2 + y^2 < z^2 \tag{1}$$

The numbering shall be consecutive and independent of the numbering of clauses, tables and figures.

For the numbering of formulae in annexes, see 4.2.6.

5.6.10 Indication of dimensions and tolerances

Dimensions and tolerances shall be indicated in an unambiguous manner.

EXAMPLE 1 80 mm x 25 mm x 50 mm (not 80 x 25 x 50 mm)

EXAMPLE 2 80 μF ± 2 μF or (80 ± 2) μF

EXAMPLE 3 $80 \begin{smallmatrix} +2 \\ 0 \end{smallmatrix}$ (not $80 \begin{smallmatrix} +2 \\ -0 \end{smallmatrix}$)

EXAMPLE 4 $80 \text{ mm} \begin{smallmatrix} +50 \\ -25 \end{smallmatrix} \mu\text{m}$

EXAMPLE 5 10 kPa to 12 kPa (not 10 to 12 kPa)

EXAMPLE 6 $0 \text{ }^{\circ}\text{C}$ to $10 \text{ }^{\circ}\text{C}$ (0 to $10 \text{ }^{\circ}\text{C}$)

In order to avoid misunderstanding, tolerances on percentages shall be expressed in a mathematically correct form.

EXAMPLE 7 Write “from 63 % to 67 %” to express a range.

EXAMPLE 8 Write “(65 ± 2) %” to express a center value with tolerance.

The form “65 ± 2 %” shall not be used.

See also annex E.

6 Presentation of typescripts

For an example layout of a typescript, see annex F.

Annex A
(informative)

Example of numbering of divisions and subdivisions

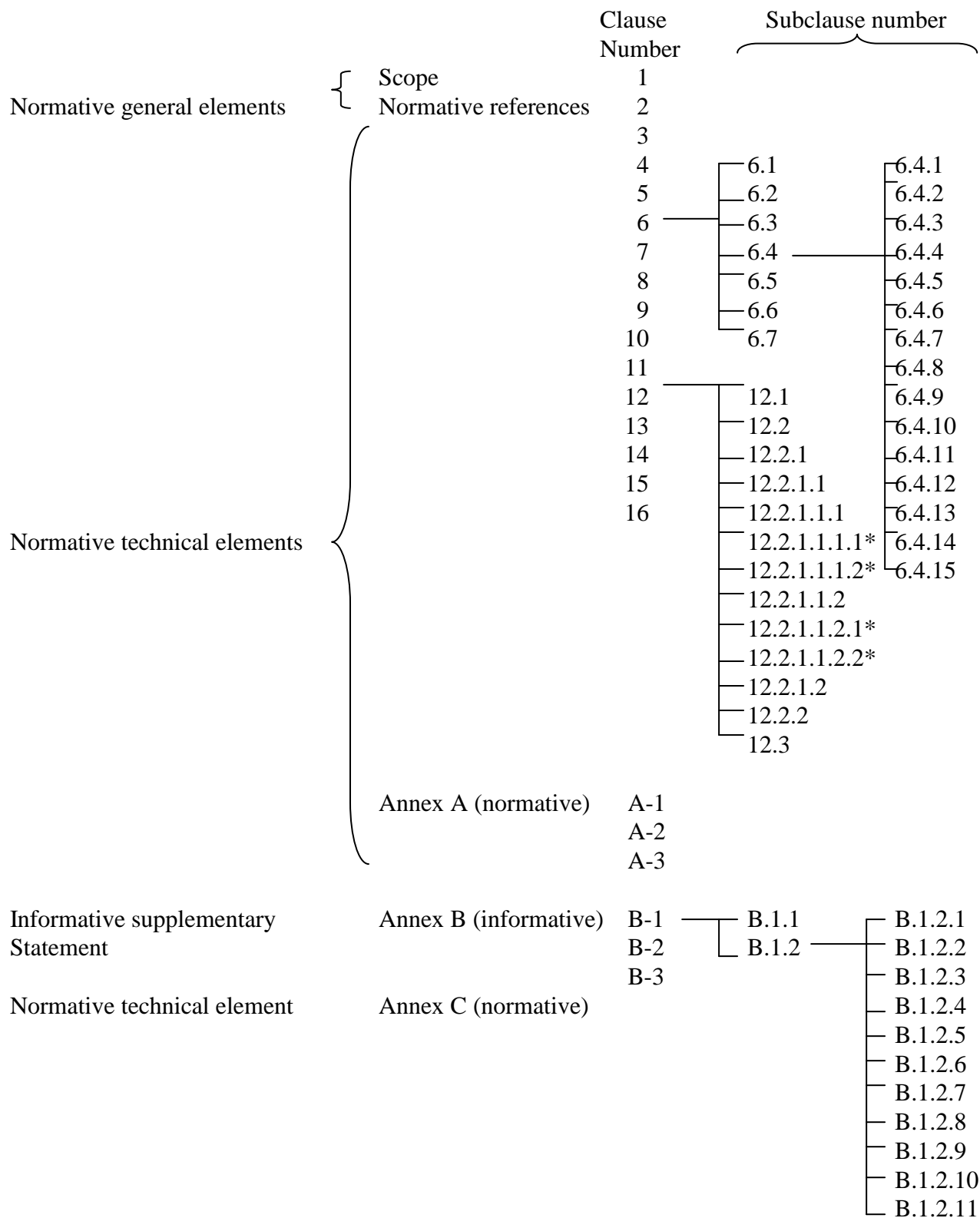

* Maximum of six levels, i.e. a clause and five levels of subclauses

Annex B (normative)

Drafting and presentation of terms and definitions

B.1 General principles

B.1.1 Types of standard

Terminology may take the form of an independent terminology standard (a vocabulary, nomenclature, or list of equivalent terms in different languages) or be included in a “Terms and definitions” clause in a standard that also deals with other aspects.

B.1.2 Choice of concepts to be defined

Any term which is not self-explanatory or commonly known and which can be differently interpreted in different contexts shall be clarified by defining the relevant concept.

Common dictionary or current technical terms shall be included only if they are used with a specific meaning in the relevant context.

Trade names (brand names) and archaic and colloquial terms shall be avoided.

Deprecated terms may be included after the preferred term but their nature shall be indicated (see B.3.3).

In an independent terminology standard, the concepts defined shall be restricted to the field corresponding to the scope of the standard. In other standards, only such concepts shall be defined as are used in those standards, apart from any additional concepts and their terms that may be deemed necessary for the understanding of these definitions.

B.1.3 Avoidance of duplications and contradictions

Before a term and a definition are established for a concept, it should be ascertained that no other term and definition for that concept exist in another International Standard.

If the concept is used in several standards, it should be defined in the most general of those standards, or in an independent terminology standard. The other standards should then refer to this standard, without repeating the definition of the concept.

When the repetition of a definition is necessary, an informative reference shall be made to the standard from which it is reproduced (see 5.6.6.5).

3.2.11

international rubber hardness degree

IRHD

Measure of hardness, the magnitude of which is derived from the depth of penetration of a specified indenter into a test piece under specified conditions

[ISO 1382:1982]

Where a standardized definition in another subject field has to be adapted, an explanation shall be given in a note.

1.1.3

natural language

language which evolves and whose rules reflect usage without necessarily being explicitly prescribed

NOTE Adapted from ISO/IEC 2382-7:1989.

If a term and a definition for a concept are established on one standard, the introduction in another standard of a different term (synonym) for the defined concept is strongly deprecated.

B.1.4 Drafting of definitions

B.1.4.1 A definition shall not take the form of, or contain a requirement.

B.1.4.2 The form of a definition shall be such that it can replace the term in context. Additional information shall be given only in the form of examples or notes (see B.3.7).

B.1.4.3 A definition given without an indication of its applicability may be taken as representing the general meaning of the term. Special meanings in particular contexts shall be indicated by designating the subject field (see B.3.5).

B.2 Independent terminology standards

B.2.1 Arrangement

An independent terminology standard containing terms and definitions should be preferably classified according to the hierarchy of the concepts. The terms and definitions of general concepts shall precede those of less general concepts. If a mixed system of concepts is used in which several groupings (according to different criteria) appear, each grouping shall be kept separate and the relevant criteria shall be indicated.

The grouping of terms shall be evident from their numbering. Each entry shall be given a reference number, and alphabetical indexes of the terms shall also be given for each language.

Lists of equivalent terms in different languages may be presented either in systematic order as indicated above (in which case alphabetical indexes shall be given for each of the languages), or in alphabetical order of the terms in the first of the languages used (in which case alphabetical indexes shall be given for each of the other languages).

B.3 Presentation

B.3.1 Layout

The preferred term (set in bold type in the printed publication) shall be placed on a new line, after its reference number, starting with a lower-case letter except for any capital letters required by the normal written form in running text. The definition shall be placed on a new line, starting with a lower-case letter, except for any capital letters required by the normal written form in running text, and shall not be followed by a full-stop.

2.4.1

delamination

separation of two adjacent plies resulting from a lack of adhesion

B.3.2 Synonyms

Admitted terms (set in normal type in the printed publication) shall each be placed on a new line, after the preferred term.

11.4.6

serializer

parallel-serial converter

dynamicizer

functional unit that converts a set of simultaneous signals into a corresponding time sequence of signals

Symbols shall be given following any admitted term(s).

Symbols for quantities in italic type, symbols for units in roman type.

If a symbol is taken from an international authority, the authority shall be identified between square brackets after the symbol, on the same line.

Information regarding the units applicable to a quantity shall be given in a note.

2.4.1

resistance

R [IEC + ISO]

(direct current) electric potential difference divided by current when there is no electromotive force in the conductor

NOTE Resistance is expressed in ohms.

Deprecated, obsolete and superseded terms (set in normal type in the printed publication) shall each be placed on a new line, after any symbols, and shall be followed by an indication of their status, in parentheses.

5.3.8

radix

base (deprecated)

positive integer by which the weight of any digit place is multiplied to obtain the weight of the digit place with the next higher weight.

B.3.3 Grammatical form of terms

Terms shall in general be presented in their basic grammatical form, i.e. nouns in the singular, verbs in the infinitive.

B.3.4 Multiple meanings

If a term is used to represent several concepts, the subject field to which each concept belongs shall be indicated between angle brackets before the definition.

If a term is used to represent several concepts, the subject field to which each concept belongs shall be indicated between angle brackets, before the definition.

2.1.17

die, noun

(extrusion) metal block with a shaped orifice through which plastic material is extruded

2.1.18

die, noun

(moulding) assembly of parts enclosing the cavity from which the moulding takes its form

2.1.19

die, noun

(punching) tool to punch sheet or film material

B.3.5 Parentheses and brackets

Parentheses and square brackets shall be used only if they constitute part of the normal written form of the term. They shall not be used to show alternative terms.

bis(dimethylthiocarbamyl) disulfide

B.3.6 Examples and notes

Examples of term usage, and notes concerning entries, shall be presented as shown below.

1.3.2

power

(mathematics) number of times, as indicated by an exponent, that a number occurs as a factor in a product

EXAMPLE The 3rd power of 2 is 8.

1.4.5

blowing agent

substance used to cause expansion in the manufacture of hollow or cellular articles

NOTE Blowing agents may be compressed gases, volatile liquids, or chemicals that decompose or react to form a gas.

5.3.8

radix

base (deprecated)

(radix numeration system) positive integer by which the weight of any digit place is multiplied to obtain the weight of the digit place with the next higher weight

EXAMPLE In the decimal numeration system the radix of each digit place is 10.

NOTE The term “base” is deprecated in this sense because of its mathematical use.

Annex C
(normative)

Drafting of the title of a standard

C.1 Elements of the title (see also 5.1.1)

C.1.1 The introductory element

The introductory element is necessary if, without it, the subject indicated in the main element is not well defined.

EXAMPLE 1

Correct: *Fork-lift trucks – Hook-on type fork arms – Vocabulary*

Incorrect: - *Hook-on type fork arms – Vocabulary*

If the main element of the title (together with the complementary element, where present) unequivocally covers the subject treated in the standard, the introductory element shall be omitted.

EXAMPLE 2

Correct: Sodium perborates for industrial use - Determination of bulk density

Incorrect: Chemicals - Sodium perborates for industrial use - Determination of bulk density

C.1.2 The main element

The main element shall always be included.

C.1.3 The complementary element

The complementary element is necessary if the standard covers only one or a few aspects of the subject indicated in the main element.

In the case of a standard published as a series of parts, the complementary element serves to distinguish and identify the parts [the introductory element (if present) and the main element remaining the same for each part].

EXAMPLE 1

PAES 231-1 *Agricultural Machinery – Rice Mills – Part 1: General*

PAES 231-2 *Agricultural Machinery – Rice Mills – Part 2: Paddy Separators*

If the standard covers several (but not all) aspects of the subject indicated in the main element, the aspects covered shall be referred to by a general term such as “specification” or “mechanical requirements and test methods” rather than be enumerated one by one.

The complementary element shall be omitted if the standard both

- covers all essential aspects of the subject indicated in the main element, and
- is (and is intended to remain) the only standard relating to this subject.

EXAMPLE 2

Correct: *Coffee grinders*

Incorrect: *Coffee grinders – Terminology, symbols, material, dimensions, mechanical properties, rated values, test methods, packaging*

C.2 Avoidance of unintentional limitation of the scope

The title shall not contain details that might imply an unintentional limitation of the scope of the standard.

However, if the standard pertains to a specific type of product, this fact shall be reflected in the title.

EXAMPLE *Aerospace – Self-locking, fixed, single –lug, anchor nuts, classification 1,100 MPa/235⁰C*

C.3 Wording

Uniformity shall be maintained in the terminology used in the titles of standards for indicating the same concept.

For standards dealing with terminology, whenever possible one of the following expressions shall be used: “Vocabulary” if the definitions of the terms are included, or “List of equivalent terms” if only equivalent terms in different languages are given.

For standards dealing with test methods, whenever possible one of the following expressions shall be used: “Test method” or “Determination of...”. Expressions such as “Method of testing”, “Method for the determination of...”, “Test code for the measurement of ...”, “Test on ...”, shall be avoided.

Annex D (normative)

Verbal forms for the expression of provisions

NOTE Only singular forms are shown.

The verbal forms in Table D.1 shall be used to indicate requirements strictly to be followed in order to conform to the standard and from which no deviation is permitted

Table D.1 - Requirement

| Verbal form | Equivalent expressions for use in exceptional cases (see 5.6.1.3) |
|---|---|
| shall | is to is required to it is required that has to only ... is permitted it is necessary |
| shall not | is not allowed [permitted] [acceptable] [permissible] is required to be not is required that ... be not is not to be |
| <p>Do not use “must” as an alternative for “shall”. (This will avoid any confusion between the requirements of a standard and external statutory obligations.)</p> <p>Do not use “may not” instead of “shall not” to express a prohibition.</p> <p>To express a direct instruction, for example referring to steps to be taken in a test method, use the imperative mood in English.</p> <p>EXAMPLE “Switch on the recorder.”</p> | |

The verbal forms shown in Table D-2 shall be used to indicate that among several possibilities one is recommended as particularly suitable, without mentioning or excluding others, or that a certain course of action is preferred but not necessarily required, or that (in the negative form) a certain possibility or course of action is deprecated but not prohibited.

Table D.2 - Recommendation

| Verbal form | Equivalent expressions for use in exceptional cases (see 5.6.1.3) |
|-------------------|--|
| should | it is recommended that ought to |
| should not | it is not recommended that ought not to |

The verbal forms shown in table D.3 are used to indicate a course of action permissible within the limits of the standard.

Table D.3 - Permission

| Verbal form | Equivalent expressions for use in exceptional cases (see 5.6.1.3) |
|---|---|
| may | is permitted is allowed is permissible |
| need not | it is not required that no ... is required |
| Do not use “possible” or “impossible” in this context. | |
| Do not use “can” instead of “may” in this context. | |
| NOTE “May” signifies permission expressed by the standard, whereas “can” refers to the ability of a user of the standard or to a possibility open to him. | |

The verbal forms shown in Table D.4 are used for statements of possibility and capability, whether material, physical and casual.

Table D.4 - Possibility and capability

| Verbal form | Equivalent expressions for use in exceptional cases (see 5.6.1.3) |
|------------------------------|---|
| can | be able to there is a possibility of it is possible to |
| cannot | be unable to there is no possibility of it is not possible to |
| NOTE See note 1 to Table D.3 | |

Annex E (informative)

Checklist concerning quantities and units to be used in PAES Standards

1. Do not mix symbols and names of units. Write, for example, either “kilometer per hour” or “km/h”, and **not** “km per hour” or “kilometer/hour”.
2. Combine numerical values written in figures with unit symbols, e.g. “5 m”. Avoid such combinations as “five m” and “5 meters”. There shall be a space between the numerical value and the unit symbol except in the case of superscript-type unit symbols used for plane angle, e.g. 5° 6' 7". However, the degree should preferably be subdivided decimally.
3. Do not use non-standardized abbreviated terms of units, such as “sec” (instead of “s” for seconds), “mins” (instead of “min” for minutes), “hrs” (instead of “h” for hours), “cc” (instead of “cm³” for cubic centimeters), “lit” (instead of “l” for liters), “amps” (instead of “A” for amperes).
4. Internationally standardized unit symbols shall not be modified by adding subscripts or other information. Write, for example,
 “ $U_{\max} = 500 \text{ V}$ ” and **not** “ $U = 500 \text{ V}_{\max}$ ”
 “a mass fraction of 5 % and **not** “5 % (*m/m*)”
 “a volume fraction of 7 %” and **not** “7 % (*V/V*)”
 (Remember that % = 0.01 and ‰ = 0.001 are “pure” numbers.)
5. Do not mix information with unit symbols, Write, for example, “the water content is 20 ml/kg” and **not** “20 ml H₂O/kg” or “20 ml of water/kg”.
6. Abbreviated terms such as “ppm”, “pphm” and “ppb” shall not be used. They are language dependent, may be ambiguous and are not really needed since they only stand for numbers, which are always more clearly expressed by means of digits. Write, for example,
 “the mass fraction in 4.2 µg/g” or “the mass fraction is 4.2 x 10⁻⁶” and **not** “the mass fraction is 4.2 ppm”
 “the relative uncertainty is 6.7 x 10⁻¹²” and **not** “the relative uncertainty is 6.7 ppb”
7. Unit symbols shall always be in roman type. Quantity symbols shall always be in italic type. Symbols representing numerical values shall be different from symbols representing the corresponding quantities.
8. Equations between quantities are preferred to equations between numerical values.
9. The quantity “weight” is a force (gravitational force) and is measured in newtons (N). The quantity “mass” is measured in kilograms (kg).
10. Quotient quantities shall not contain the word “unit” in the denominator. For example, write “mass per length” and **not** “mass per unit length”.

11. Distinguish between an object and any quantity describing the object, e.g. between “surface” and “area”, “body” and “mass”, “resistor” and “resistance”, “coil” and “inductance”.
12. Write, for example
“10 mm to 12 mm” and **not** “10 to 12 mm”
“0 °C to 10 °C” and **not** “0 to 10 °C”
“24 mm x 36 mm” and **not** “24 x 36 mm”
“23 °C ± 2 °C” or “(23 ± 2) °C” and **not** “23 ± 2 °C”
“(60 ± 3) %” and **not** “60 ± 3 %”
13. Two or more physical quantities cannot be added or subtracted unless they belong to the same category of mutually comparable quantities. Accordingly, the method of expression for a relative tolerance such as 230 V ± 5 % does not comply with this basic law of algebra. The following methods of expression may be employed instead:
“230 x (1 ± 5 %) V”
“230 x (1 ± 0.05) V”
“230 V, with a relative tolerance of ± 5 %”
14. Do not write “log” in formulae if the base needs to be specified. Write “lg”, “ln”, “lb” or “log”.
15. Use the mathematical signs and symbols recommended in ISO 31-11m e.g. “tan” and **not** “tg”.

Annex F
(informative)

Example layout of a typescript

- 1. Scope
[Redacted]
- 2. Normative references
[Redacted]
- 3. Title
 - 3.1 Title
 - 3.1.1 [Redacted]
 - 3.1.2 [Redacted]
 - 3.1.3 [Redacted]
 - 3.2 Title
[Redacted]
 - a) [Redacted]
 - b) [Redacted]
- 3.3 Title
[Redacted]
- NOTE [Redacted]
- 4. Title
 - 4.1 Title
 - 4.1.1 Title
[Redacted]
 - 4.1.2 Title
[Redacted]
 - NOTE 1 [Redacted]
 - NOTE 2 [Redacted]
 - 4.2 Title
 - NOTE 1 [Redacted]
 - NOTE 2 [Redacted]