

PHILIPPINE NATIONAL STANDARD

**PNS/BAFS 345:2022
ICS 65.060.10**

Walking-Type Agricultural Tractor — Specifications — Part 1: Pull-type



BUREAU OF AGRICULTURE AND FISHERIES STANDARDS
BPI Compound Visayas Avenue, Diliman, Quezon City 1101 Philippines
Trunkline: **(632) 928-8741 to 64 loc. 3301-3319**
E-mail: **bafs@da.gov.ph**
Website: **www.bafs.da.gov.ph**

Foreword

Since 2000, the local agricultural industry has observed technological innovations and advancements on the design, fabrication, and operation of walking-type agricultural tractors available in the market. Thus, it was necessary to revise the existing national standards on the walking-type agricultural tractor. In response, the Agricultural Machinery Testing and Evaluation Center (AMTEC)-University of the Philippines Los Baños (UPLB) initiated the development of the standards on walking-type agricultural tractor — Specifications — Part 1 (Pull-type), Part 2 (Rotary-tilling type) and Part 3 (Float-assisted tiller) and Methods of Test. The development of these standards was made in collaboration with the Bureau of Agriculture and Fisheries Standards (BAFS)-Department of Agriculture (DA) as the mandated agency to develop Philippine National Standards (PNS) for agriculture and fisheries machinery and infrastructures.

The Technical Working Group (TWG) tasked to develop the PNS was created through Special Order (SO) No. 617, series of 2022 (Amendment to Special Order No. 487, series of 2022 [Addendum to Special Order 103, series of 2022 entitled, “Creation of TWG for the Development of PNS for Agriculture and Fishery Products, Machineries, and Infrastructures”]). The TWG was composed of representatives from the relevant government agencies, academe, and research institutions. The draft PNS underwent a series of TWG meetings and stakeholder consultations via online platforms before their endorsement to the DA Secretary for approval.

This PNS/BAFS edition includes the following significant changes compared to PAES 109:2000 (Agricultural machinery – Walking-type agricultural tractor – Specifications – Part 1: Pull-type):

- a) Inclusion of tractors with other transmission system in the “Scope”; and
- b) Inclusion and modification of provisions for “WTAT Parts and Components”, “Fabrication Requirements”, “Performance Requirements”, “Safety, Workmanship, and Finish”, “After-sales Requirements”, “Maintenance and Operation”, “Sampling”, “Testing”, and “Marking and Labeling”.

This Standard cancels and replaces PAES 109:2000. This PNS was drafted in accordance with the BAFS-Standards Development Division (SDD) Standardization Guide No. 1: Writing the Philippine National Standards.

Table of Contents

Foreword	ii
1 Scope.....	1
2 Normative References	1
3 Terms and Definitions	2
4 WTAT Parts and Components	3
4.1 Components	3
4.2 Controls	4
5 Fabrication Requirements	4
6 Performance Requirements	5
7 Safety, Workmanship, and Finish	5
8 After-sales Requirements	6
9 Maintenance and Operation.....	6
10 Sampling.....	7
11 Testing.....	7
12 Marking and Labeling.....	7
Bibliography	8

1 Scope

This Standard specifies the minimum requirements for Walking-Type Agricultural Tractor (WTAT) which is classified as pull-type. This includes, but not limited to, tractors with chain and sprocket transmission, geared transmission, other transmission system, and combination thereof.

2 Normative References

The following documents are referred to in the text in such a way that some or all of their contents constitute the requirements of this document. The latest edition of the referenced documents (including any amendments) applies.

Agricultural Machinery Testing and Evaluation Center (AMTEC)-University of the Philippines Los Baños (UPLB). (2000). Agricultural machinery – Hexagonal axle and hub for walking-type agricultural tractor – Specifications (PAES 108:2000). <https://amtec.ceat.uplb.edu.ph/wp-content/uploads/2019/07/PAES-108-2000.pdf>

AMTEC-UPLB. (2000). Agricultural machinery – Hitch for walking-type agricultural tractor – Specifications (PAES 107:2000). <https://amtec.ceat.uplb.edu.ph/wp-content/uploads/2019/07/PAES-107-2000-Agricultural-Machinery-Hitch-for-Walking-type-Agricultural-Tractor-Specifications.pdf>

AMTEC-UPLB. (2000). Agricultural machinery – Methods of sampling (PAES 103:2000). <https://amtec.ceat.uplb.edu.ph/wp-content/uploads/2019/07/PAES-103-2000-Agricultural-Machinery-Method-of-Sampling.pdf>

AMTEC-UPLB. (2000). Agricultural machinery – Operator’s manual – Content and presentation (PAES 102:2000). <https://amtec.ceat.uplb.edu.ph/wp-content/uploads/2019/07/PAES-102-Operators-Manual-Content-and-Presentation.pdf>

AMTEC-UPLB. (2000). Engineering materials – Roller chains and sprockets for agricultural machines – Specifications and applications (PAES 303:2000). <https://amtec.ceat.uplb.edu.ph/wp-content/uploads/2020/06/PNS-PAES-303-2000-Engineering-Materials-Roller-Chain-and-Sprochets-Specifications-and-Appli.pdf>

Bureau of Agriculture and Fisheries Standards (BAFS)-Department of Agriculture (DA). (2016). Agricultural and fisheries machinery – Guidelines on after-sales service (PNS/BAFS PAES 192:2016). <https://amtec.ceat.uplb.edu.ph/wp-content/uploads/2020/06/PNS-BAFS-192.2016-Guidelines-on-After-sales-services.pdf>

BAFS-DA. (2022). Technical means for ensuring safety – Guidelines (PAES 330:2022).

https://bafs.da.gov.ph/bafs_admin/admin_page/pns_file/PNS.BAFS%20330.2022_PNS%20Technical%20Means%20for%20Ensuring%20Safety%20-%20Guidelines.pdf

BAFS-DA. (2022). Walking-type agricultural tractor — Methods of test (PNS/BAFS 348:2022).

International Organization for Standardization (ISO). (2019). Graphical symbols — Safety colours and safety signs — Registered safety signs (ISO 7010:2019).

3 Terms and Definitions

For the purpose of this Standard, the following definitions shall apply:

3.1

actual field capacity

actual area covered per unit time of operation, expressed in ha/h

3.2

main clutch

clutch used to disengage power to both driving wheels or cage which enables the WTAT to move forward or stop

3.3

pull-type

walking-type agricultural tractor capable of pulling various kinds of properly matched implements and attachments; also commonly referred to as traction type

3.4

transmission assembly

combination of belt, pulleys, chain, sprockets, and gears that transmits power from the engine to the driving wheels or cage

3.5

transmission efficiency

ratio of the power transmitted to the axle from the power transmitted to the input shaft of the transmission system expressed in percent (%)

3.6 walking-type agricultural tractor (WTAT)

self-propelled machine having a single axle designed primarily to pull and propel trailed, semi mounted and/or mounted agricultural implements and machinery that are properly matched and with the operator walking behind; also commonly referred to as hand tractor or pedestrian tractor

4 WTAT Parts and Components

4.1 Components

The typical construction and components of the pull-type WTAT are shown in Figure 1.

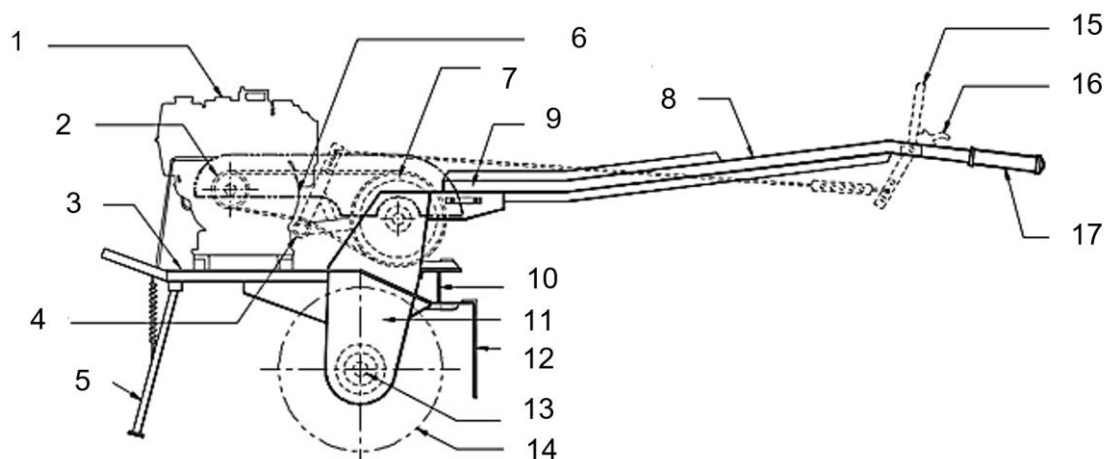

Key

1	Engine	10	Hitch assembly
2	Engine pulley	11	Transmission assembly
3	Engine mounting frame	12	Mud guard
4	Idler pulley	13	Axle
5	Stand assembly	14	Cage wheel
6	Belt guard	15	Main clutch lever
7	Input shaft pulley	16	Throttle lever
8	Handle bar	17	Hand grip
9	Handle bar adjustment		

Figure 1. Components of pull-type WTAT (adapted from AMTEC-UPLB, 2001)

4.2 Controls

4.2.1 Speed control lever

The speed control lever shall be provided and accessible to and operated from the perspective of the operator. It shall be provided with a detent mechanism capable of setting and retaining/locking the speed at any point within the range of the engine speed. It can be classified according to the following:

4.2.1.1 Vertical type

The speed control lever is pushed forward to increase engine speed and pulled rearward to decrease engine speed.

4.2.1.2 Horizontal type

The speed control lever is pulled to the left to increase engine speed and to the right to decrease engine speed.

4.2.2 Main clutch lever

The main clutch lever shall be provided and accessible to and operated from the perspective of the operator. It can be classified according to the following:

4.2.2.1 Vertical type

The main clutch lever is pushed forward to start the forward motion of the WTAT and is pulled rearward to stop the WTAT. An over-center linkage shall lock the lever in the forward engaged position.

4.2.2.2 Horizontal type

The main clutch lever is pushed upward to start the forward motion of the WTAT and is pulled downward to stop the WTAT. A lock shall be provided to hold the lever in the upward engaged position.

5 Fabrication Requirements

5.1 The WTAT shall be generally made of steel bars and sheet metals.

5.2 The chain and sprocket used shall conform to PAES 303:2000 (Engineering materials – Roller chains and sprockets for agricultural machines – Specifications and applications) and shall have provisions for refilling of lubricating oil.

- 5.3** The hand grip shall be made of non-slip material and shall have a minimum nominal diameter of 25 mm.
- 5.4** Mechanism for handle bar height adjustment with at least three settings shall be provided. The handle bar height shall be 650 mm to 800 mm.
- 5.5** The hitch of the WTAT shall be in accordance with the specifications of PAES 107:2000 (Agricultural machinery – Hitch for walking-type agricultural tractor – Specifications).
- 5.6** There shall be a provision for engine speed controller within the reach of the operator during operation.
- 5.7** Stand assembly for use when the WTAT is not in operation shall be provided.

6 Performance Requirements

- 6.1** The power requirement of the pull-type WTAT's prime mover shall not exceed 13.5 kW.
- 6.2** The actual field capacity as specified by the manufacturer shall be attained.
- 6.3** The WTAT shall meet the following laboratory performance criteria if applicable:
- 6.3.1** The peak transmission efficiency of the WTAT shall be at least 85%.
- 6.3.2** The WTAT shall have no breakdowns/malfunctions (e.g., failure of components, etc.) during the five-hour continuous running test.

7 Safety, Workmanship, and Finish

- 7.1** There shall be earmuffs or other ear protection device provided for the operator to use when 95 dB(A) is exceeded during operation. Recommendations for use of ear protection device shall likewise be indicated in the operator's manual.
- 7.2** The WTAT shall be free from any manufacturing defects that may be detrimental to its operation.
- 7.3** All metal surfaces shall be painted properly.
- 7.4** Parts of the WTAT that are exposed to the operator shall be free from sharp edges and rough surfaces.

Part 1: Pull-type

- 7.5** Appropriate labels, safety symbols, and warning notices shall be provided in accordance with PNS/BAFS 330:2022 (Technical means for ensuring safety – Guidelines).
- 7.6** All controls shall be in accordance with PNS/BAFS 330:2022 (Technical means for ensuring safety – Guidelines).
- 7.7** All exposed hot surfaces shall be provided with heat shield or protection to minimize the possibility of inadvertent contact with the operator.
- 7.8** Mechanism for emergency stop of the engine and immediate load disengagement of the transmission system shall be provided.
- 7.9** Mechanism for belt transmission adjustment shall be provided.
- 7.10** Belt cover and mud guard shall be provided. All other moving parts shall have safety guards.
- 7.11** There shall be a provision for means to minimize vibration.
- 7.12** The hexagonal axle shall be in accordance with the specifications of PAES 108:2000 (Agricultural machinery – Hexagonal axle and hub for walking-type agricultural tractor – Specifications).
- 7.13** The axle shall be able to accommodate compatible pneumatic tires provided for transport.

8 After-sales Requirements

Requirements for the after-sales services shall conform to PNS/BAFS/PAES 192:2016 (Agricultural and fisheries machinery – Guidelines on after-sales service).

9 Maintenance and Operation

- 9.1** Each WTAT unit shall be provided with the basic hand tools as recommended by the manufacturer. Separate basic tools for the engine shall be provided. The sizes of the hand tools shall be specified in metric units and shall be based on the applicable sizes required for operation and maintenance of the WTAT.
- 9.2** Operator's manual based on PAES 102:2000 (Agricultural machinery – Operator's manual – Content and presentation), maintenance schedule, and list of the warrantable parts of the WTAT shall be provided. The operator's manual shall also include the minimum and maximum engine power requirements.

10 Sampling

The WTAT shall be sampled for testing in accordance with PAES 103:2000 (Agricultural machinery – Method of sampling) or any other suitable method of selection.

11 Testing

The sampled WTAT shall be tested in accordance with PNS/BAFS 348:2022 (Walking-type agricultural tractor — Methods of test).

12 Marking and Labeling

12.1 Each unit of WTAT shall be engraved or embossed either on its body or on a metal nameplate attached at the most visible place with the following information:

- a) Model;
- b) Serial number;
- c) Country of manufacture/origin (if imported)/ “Made in the Philippines” (if manufactured in the country); and
- d) Power requirement, kW.

12.2 Safety/precautionary markings shall be provided as per ISO 7010:2019 (Graphical symbols — Safety colours and safety signs — Registered safety signs). Mandatory precautions shall be embossed on blue background and white graphics and warning signs shall be printed on yellow background and black graphics.

12.3 The markings shall be durably bonded to the base surface material. It shall be all weather resistant and under normal cleaning procedures.

Bibliography

- Agricultural Machinery Testing and Evaluation Center (AMTEC)-University of the Philippines Los Baños (UPLB). (2000). Agricultural machinery – Hexagonal axle and hub for walking-type agricultural tractor – Specifications (PAES 108:2000). <https://amtec.ceat.uplb.edu.ph/wp-content/uploads/2019/07/PAES-108-2000.pdf>
- Agricultural Machinery Testing and Evaluation Center (AMTEC)-University of the Philippines Los Baños (UPLB). (2000). Agricultural machinery – Hitch for walking-type agricultural tractor – Specifications (PAES 107:2000). <https://amtec.ceat.uplb.edu.ph/wp-content/uploads/2019/07/PAES-107-2000-Agricultural-Machinery-Hitch-for-Walking-type-Agricultural-Tractor-Specifications.pdf>
- Agricultural Machinery Testing and Evaluation Center (AMTEC)-University of the Philippines Los Baños (UPLB). (2000). Agricultural machinery – Methods of sampling (PAES 103:2000). <https://amtec.ceat.uplb.edu.ph/wp-content/uploads/2019/07/PAES-103-2000-Agricultural-Machinery-Method-of-Sampling.pdf>
- Agricultural Machinery Testing and Evaluation Center (AMTEC)-University of the Philippines Los Baños (UPLB). (2000). Agricultural machinery – Operator’s manual – Content and presentation (PAES 102:2000). <https://amtec.ceat.uplb.edu.ph/wp-content/uploads/2019/07/PAES-102-Operators-Manual-Content-and-Presentation.pdf>
- Agricultural Machinery Testing and Evaluation Center (AMTEC)-University of the Philippines Los Baños (UPLB). (2000). Engineering materials – Roller chains and sprockets for agricultural machines – Specifications and applications (PAES 303:2000). <https://amtec.ceat.uplb.edu.ph/wp-content/uploads/2020/06/PNS-PAES-303-2000-Engineering-Materials-Roller-Chain-and-Sprockets-Specifications-and-Appli.pdf>
- Agricultural Machinery Testing and Evaluation Center (AMTEC)-University of the Philippines Los Baños (UPLB). (2022). AMTEC test reports on walking-type agricultural tractor (pull-type) [Unpublished raw data].
- Bureau of Agriculture and Fisheries Standards (BAFS)-Department of Agriculture (DA). (2016). Agricultural and fisheries machinery – Guidelines on after-sales service (PNS/BAFS PAES 192:2016). <https://amtec.ceat.uplb.edu.ph/wp-content/uploads/2020/06/PNS-BAFS-192.2016-Guidelines-on-After-sales-services.pdf>

Bureau of Agriculture and Fisheries Standards (BAFS)-Department of Agriculture (DA). (2022). Technical means for ensuring safety – Guidelines (PAES 330:2022).

https://bafs.da.gov.ph/bafs_admin/admin_page/pns_file/PNS.BAFS%20330.2022_PNS%20Technical%20Means%20for%20Ensuring%20Safety%20-%20Guidelines.pdf

Bureau of Agriculture and Fisheries Standards (BAFS)-Department of Agriculture (DA). (2022). Walking-type agricultural tractor — Methods of test (PNS/BAFS 348:2022).

International Organization for Standardization (ISO). (2019). Graphical symbols — Safety colours and safety signs — Registered safety signs (ISO 7010:2019).

Occupational Safety and Health Center (OSHC)-Department of Labor and Employment (DOLE). (2016). Occupational safety and health standards.

https://www.dole.gov.ph/php_assets/uploads/2019/04/OSH-Standards-2017-2.pdf

The consumer act of the Philippines, Republic Act No. 7394. (1992).

<https://www.officialgazette.gov.ph/1992/04/13/republic-act-no-7394-s-1992/>

Department of Agriculture (DA)
Bureau of Agriculture and Fisheries Standards (BAFS)

in collaboration with:

University of the Philippines Los Baños (UPLB)
Agricultural Machinery Testing and Evaluation Center (AMTEC)

**Technical Working Group (TWG) for the Development of Philippine National
Standard on Walking-type Agricultural Tractor — Specifications — Part 1: Pull-
type**

Chairperson

Dupla, Ace Philip, ABE
Bureau of Agricultural and Fisheries Engineering (BAFE)-DA

Members

- | | | | |
|---|--|----|--|
| 1 | Rosas, Ronald Melvin, ABE
BAFE-DA | 8 | Gallegos, Ralph Kristoffer, PhD |
| 2 | Geronimo, Czarlemagne, ABE | 9 | Zubia, Omar, PhD
UPLB-Institute of Agricultural and
Biosystems Engineering (IABE) |
| 3 | Macalintal, Francia, ABE
Philippine Council for Agriculture
and Fisheries PCAF-DA | 10 | Perez, Jemuel |
| 4 | Macaranas, Raymund Joseph,
ABE
Philippine Center for Postharvest
Development and Mechanization
(PHilMech)-DA | 11 | Perez, Nimrod
Aton Marketing |
| 5 | Alcaraz, Joel, PhD
Isabela State University (ISU) | 12 | Gandola, Lorena |
| 6 | Sison, Joseph | 13 | Lagas, Ceferino
Mindanao Agricultural Machinery
Industry Association (MAMIA) |
| 7 | Tamayo, Rodolfo
Agricultural Machinery
Manufacturers and Distributors
Association (AMMDA) | 14 | Tuates, Andres Jr., ABE
Philippine Society of Agricultural
and Biosystems Engineers,
(PSABE) Inc. |
| | | 15 | Hernandez, Gari Pellinor, DVM |
| | | 16 | Roscom, Karen Kristine, PhD |
| | | 17 | Villanueva, Joshua, ABE
BAFS-DA |

Management Team

Alipio, Ray, ABE
Magmanlac, Alphonse Regin, ABE
Eusebio, Romulo, ABE
Raytana, Fatima Joy, ABE
Agoncillo, Mary Christine, ABE
Dizon, Paul John
AMTEC-UPLB

Advisers

Fajardo, Arthur, PhD
AMTEC-UPLB

Mamaril, Vivencio, PhD
Mula, Myer, PhD
BAFS-DA



BUREAU OF AGRICULTURE AND FISHERIES STANDARDS

**BPI Compound Visayas Avenue, Diliman, Quezon City 1101 Philippines
T/ (632) 928-8741 to 64 loc. 3301-3319
E-mail: bafs@da.gov.ph
Website: www.bafs.da.gov.ph**