

## **Foreword**

The formulation of this national standard was initiated by the Agricultural Machinery Testing and Evaluation Center (AMTEC) with the support from Department of Agriculture.

This standard has been technically prepared in accordance with PNS 01-4:1998 (ISO/IEC Directives Part 3:1997) – Rules for the Structure and Drafting of International Standards.

The word “shall” is used to indicate requirements strictly to be followed in order to conform to the standard and from which no deviation is permitted.

The word “should” is used to indicate that among several possibilities one is recommended as particularly suitable, without mentioning or excluding others, or that certain course of action is preferred but not necessarily required.

In the preparation of this standard, the following documents/publications were considered:

Bautista, E.U., A. U. Khan, A. Vasallo and A. Caballes. *Operation Manual: IRRI Drum Seeder for lowland Paddies*. Agricultural Engineering Department, The International Rice Research Institute (IRRI), P. O. Box 933, Manila.

Bautista, E.U. and E. C. Gagelonia. *Technology!: Rice Drum Seeder*. Philippine Council for Agriculture, Forestry, and Natural Resources Research and Development, Los Baños, Laguna.

Japan International Cooperation Agency. 1976. Text Book of Agricultural Machinery.

Kepner, R.A., R. Bainer and E.L. Barger. 1978. Principles of Farm Machinery. 3<sup>rd</sup> Edition. AVI Publishing Company, Inc. Westport, Connecticut.

Regional Network for Agricultural Machinery (RNAM). 1991. Agricultural Machinery Design and Data Handbook (Seeders and Planters).

Resurreccion, A.N. 1979. Design of a Metering Device of Rootzone Granular Fertilizer Applicators. Philippine Agricultural Engineering Journal. X(4).

Smith, D.W., B.G. Sims and D.H. O'Neill. 1994. *Testing and Evaluation of Agricultural Machinery and Equipment – Principles and practices*. FAO Agricultural Services Bulletin 110.

Stevens G.N. 1982. *Equipment Testing and Evaluation*. Overall Division, National Institute of Agricultural Engineering (NIAE), Wrest Park, Silsoe Bedford England.

---

**Agricultural Machinery – Rice Drum Seeder – Specifications**

---

**1 Scope**

This standard specifies the requirements for construction and performance of a manually-operated rice drum seeder used for wet field.

**2 References**

The following normative documents contain provisions, which, through reference in this text, constitute provisions of this National Standard:

PAES 102:2000, Agricultural Machinery – Operator’s Manual – Content and Presentation

PAES 103:2000, Agricultural Machinery – Method of Sampling

PAES 144:2005, Agricultural Machinery – Drum Seeder- Methods of Test

**3 Definition**

For the purpose of this standard, the following definitions shall apply:

**3.1****adjusting ring**

metal or rubber ring positioned to regulate the seeding rate

**3.2****drum hopper**

part of the seeder where the seeds are loaded and metered (Figure 1)

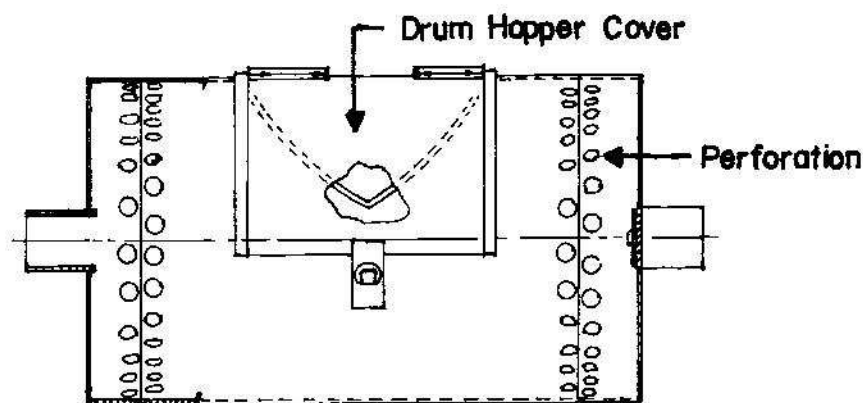

**Figure 1 – Drum hopper**

### 3.3

#### drum seeder

planting equipment (Figure 2) used for pre-germinated rice seeds for wet fields

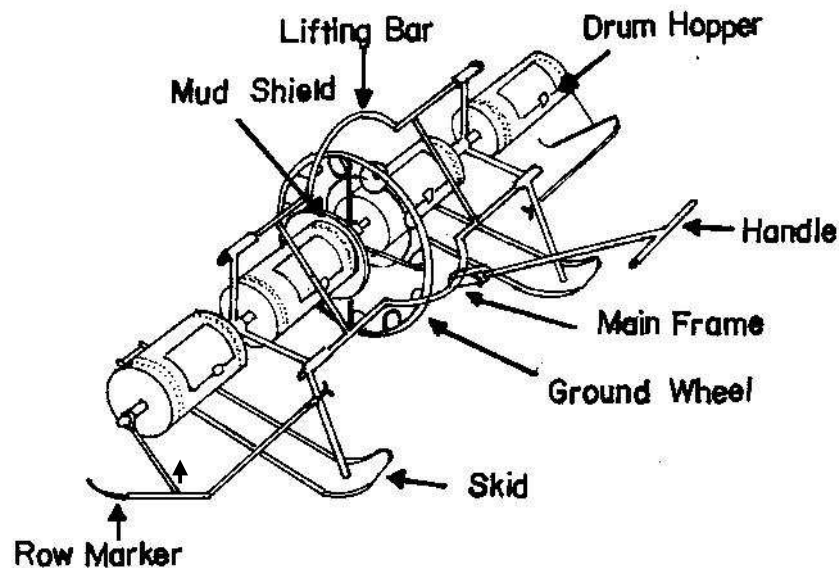

Figure 2 – Drum Seeder

### 3.4

#### ground wheel

part of the seeder which provides traction and activates rotation of the hopper for seed discharge

### 3.5

#### seeding rate

amount of seeds discharged from the seeder per unit time or area

#### skid

part of the seeder which serves as a float to prevent the seeder from sinking

## 4 Principle of Operation

The rice drum seeder uses a simple metering system in which the perforations on the periphery at both ends of the cylinder (drum hopper) meter the seeds. As the machine is pulled, the cylinder driven by a ground wheel rotates. As it rotates, seeds fall from the holes to the sliding surface in rows. Seeding can be set at three different rates through adjusting the sliding ring which is attached to the hopper. Seeds are placed on the surface or at a few millimeters under the soil. In the absence of a row marker, skids may also serve as a row marker.

## 5 Materials for Construction

The drum seeder shall be generally made of steel, plastic and rubber.

## **6 Construction Requirement**

- 6.1** The rice drum seeder shall be made of light materials with bare weight not exceeding 11 kg.
- 6.2** The rice drum seeder shall be provided with handle bar adjustment.
- 6.3** The drum hopper shall be replaceable.
- 6.4** The adjusting ring shall easily be positioned on the hopper.
- 6.5** The v-shaped ribbing shall be installed in the drum hopper cover.

## **7 Performance Requirements**

- 7.1** The drum seeder shall be easy to set-up and operate.
- 7.2** The manufacturer's specified working capacity of the drum seeder shall be attained.
- 7.3** The seeding rate specified by the manufacturer shall be attained.
- 7.4** The drum seeder shall produce good quality work such as accuracy of discharge rate, uniformity of seed placement and ease of operation and maintenance in a well prepared and leveled field.
- 7.5** Each drum hopper shall be provided with a pair of adjusting rings to regulate seeding rate.

## **8 Workmanship and Finish**

- 8.1** The seeder shall be free from manufacturing defects such as sharp edges and surfaces that may be detrimental to the operator.
- 8.2** The seeder shall be free from rust and shall be painted properly.

## **9 Warranty for Construction and Durability**

- 9.1** The construction shall be rigid and durable without major breakdown of its major components within six (6) months.
- 9.2** Warranty shall be provided for parts and services within six (6) months after the purchase of the drum seeder.

## **10 Maintenance and Operation**

- 10.1** Grease points for lubrication of axles shall be provided.

- 10.2 Adjusting rings shall be easily positioned on the hopper after painting.
- 10.3 An operator's manual which conforms to PAES 102 shall be provided.

## 11 Sampling

The drum seeder shall be sampled in accordance with PAES 103.

## 12 Test Method

The sampled drum seeder shall be tested for performance and durability in accordance with PAES 144.

## 13 Marking and Labeling

Each drum seeder shall be marked in English with the following information using a plate, stencil or by directly punching it at the most conspicuous place:

- 13.1 Registered Trademark of the Manufacturer
- 13.2 Brand
- 13.3 Model
- 13.4 Serial number
- 13.5 Name and address of the manufacturer
- 13.6 Name and address of the importer, if imported (optional)
- 13.7 Country of manufacture (if imported) / "Made in the Philippines" (if manufactured in the Philippines)
- 13.8 Safety/precautionary markings